

USE AND MAINTENANCE
FPT N45 SM2A Бриз Моторс

N **SERIES**
FPT N45 SM2A Бриз Моторс

G-DRIVE ENGINES

<http://www.brizmotors.ru/equipment/iveco/gen75ma/>



ENGINE TECHNICAL DATA N45 SM1A/SM1X/ SM2A/SM2X - N45 TM1A/TM2A

The technical code and serial number are indicated on a plate, which is located on different parts of the engine, according to the model: flywheel casing, tappet cover, other.

Code	N45 SM1A/SM1X/SM2A/SM2X N45 TM1A/TM2A	
Engine family	F4	
Cycle	4-stroke diesel	
Number and arrangement of cylinders	4, in line	
Bore x stroke	104 x 132 mm	
Total displacement	4,500 cm ³	
Air system	Supercharged and Aftercooled ⁽¹⁾	
Injection type	Direct with rotating pump	
Engine direction of rotation	Anticlockwise (seen from flywheel side)	
Speed regulator	Mechanical	
Dry weight	SM	~450 kg
	TM	~500 kg

1) Excluding versions SM

Electrical system	12 V
Accumulator/s	
- capacity	100 Ah or above
- discharge current	650 A or above

Performance (*)		N45 SM1A
EU/2002/88/CE	Prime	53,5 kWm @ 1,500 rpm
	Stand-by	59 kWm @ 1,500 rpm
Performance (*)		N45 SM1X
(TIER 3)	Prime	-
	Stand-by	69 kWm @ 1,800 rpm
Performance (*)		N45 SM2A
EU/2002/88/CE	Prime	66 kWm @ 1,500 rpm
	Stand-by	73 kWm @ 1,500 rpm
Performance (*)		N45 SM2X
EU/2002/88/CE	Prime	-
	Stand-by	59 kWm @ 1,800 rpm
Performance (*)		N45 TM1A
EU/2002/88/CE	Prime	77 kWm @ 1,500 rpm
	Stand-by	85 kWm @ 1,500 rpm
Performance (*)		N45 TM2A
EU/2002/88/CE	Prime	87 kWm @ 1,500 rpm
	Stand-by	96 kWm @ 1,500 rpm

(*) Net power to the flywheel in compliance with ISO 8528.

WARNING

Any alteration of the above mentioned characteristics is strictly prohibited, penalty invalidation of the guarantee and absence of all liability on the part of FPT.

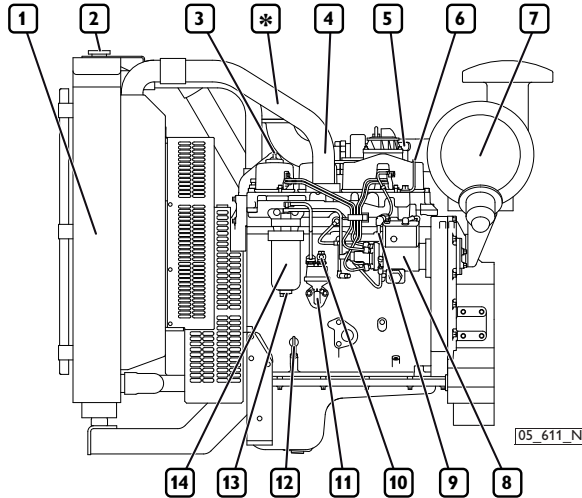

N45 SM1A/SM1X/SM2A/SM2X - N45 TM1A/TM2A

1. Heat exchanger/s - 2. Coolant filler cap - 3. Oil filler cap - 4. Engine air inlet manifold - 5. Oil vapour bleeder - 6. Lifting U-bolt - 7. Air filter - 8. Injection pump - 9. Fuel outlet connector to tank - 10. Fuel inlet manifold from tank - 11. Hand pump - 12. Oil dipstick - 13. Fuel filter condensation drainage plug - 14. Fuel filter.

*) Excluding versions SM

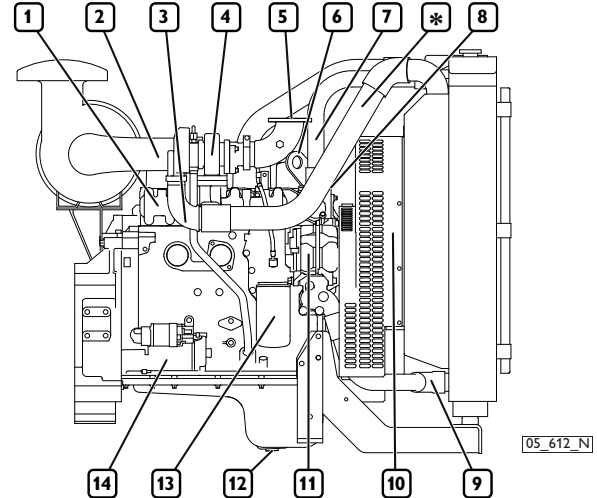

N45 SM1A/SM1X/SM2A/SM2X - N45 TM1A/TM2A

1. Exhaust manifold - 2. Turbocharger air intake - 3. Turbocharging air outlet - 4. Turbocharger- 5. Exhaust outlet - 6. Lifting U-bolt - 7. Coolant outlet manifold from engine - 8. Location of thermostatic valve - 9. Engine coolant inlet connector sleeve - 10. Fan - 11. Alternator - 12. Lubricant oil discharge plug - 13. Oil filter - 14. Electrical starter motor.

*) Excluding versions SM

CAUTION!



Do not carry out maintenance operations when the electric power supply is turned on: always check to ensure that the appliances are properly earthed. During diagnosis and maintenance operations, make sure that your hands and feet are dry, and whenever possible use insulating stands.

CAUTION!



The conditions provoking the emergency power unit start may suddenly occur. Whenever executing checks and maintenance operations, strictly follow the safety instructions prescribed by the unit's Manufacturer and power unit system's outfitter to operate safely and prevent injury.

REFUELLING

Parts to be supplied	N45	N67	
	litres (kg)	litres (kg)	
Cooling circuit ⁽¹⁾	engine ^(*)	8,5	10,5
	G-Drive ^(**)	18,5	25,5
<hr/>			
Lubrication circuit ⁽²⁾			
total capacity ⁽³⁾	12,8 (11,8)	17,2 (15,8)	
<hr/>			
Periodic changing:			
oil sump at minimum level	7 (6,5)	8,7 (8)	
oil sump at maximum level	11,5 (10,5)	15,2 (14)	
<hr/>			
Fuel tank ⁽⁴⁾	-	-	
<hr/>			

(*) The amounts indicated relate to the standard configuration of the engine only.

(**) Total capacity.

(1) Use a mixture of water and 50% PARAFU 11 even during the summer months. As an alternative to PARAFU 11, use another product that complies with international specifications SAE J 1034.

(2) Use lubricants complying with the following international specifications: ACEA E3-E5-E7; API CF - CH4 - CI4 (associated to fuels with a sulphide percentage of 0,001% = 10ppm) MIL-L-2104F. FPT suggest to use original Urania LD7 (15W-40) / Urania Turbo LD (15W-40) lubricant.

Oil consumption is considered acceptable when it reaches a maximum of 0.5% of fuel consumption.

- (3) The amounts indicated refer to initial refuelling, and include filling the engine, sump and filter.
- (4) Use STANDARD fuel compliant to the EN 590:2012 (maximum sulphur percentage of 0.001%). The use of additives is discouraged. Note that EN 590:2012 allows a blend up to 7% of BIODIESEL, meeting the EN 14214 specification. KEROSENE-based fuel known as XF63, F63, F34, F35, JP8 is not allowed. Mixtures containing water as in a boil are not permitted, as shown in the CUNA NC 637-01 (GECAM) and AFNORM 5-02 (AQUAZOLE) norms.

Low temperature diesel

EN590 specifications distinguish different classes of diesel fuel, identifying the characteristics of those best suited to low temperatures. It is entirely up to the Oil companies to comply with these regulations, which foresee that fuels suited to the climactic and geographic conditions of the various Countries be distributed.

WARNING

Refuelling from drums or tanks may result in pollution of the diesel fuel, with the risk of damage to the injection system; if necessary, filter the fuel in a suitable manner or allow sedimentation of the impurities before refuelling.

FREQUENCY

Controls (when in use)	Frequency
Check oil level in engine	Daily
Check coolant level	Daily
Check that the heat exchangers are clean	Daily
Check that the air filter is clean	Daily
Drain water from the fuel pre-filter	150 hours ⁽¹⁾
Check/top up electrolyte level in batteries and clean terminals	Half-yearly

The maintenance intervals indicated below take into account the typical working factors for various types of engine use; the most suitable interval for maintenance operations for the various applications will be indicated by the maintenance staff, according to the way and working conditions in which the engine is used.

 Planned maintenance	Frequency
Check state and tension of belt	300 hours ⁽²⁾
Change oil	600 hours ^{(3) (4)}
Change oil filter/s	600 hours ^{(3) (4) (5)}
Change fuel filter/s	600 hours ^{(3) (1) (5)}
Change fuel pre-filter	600 hours ^{(3) (1)}
Replacing the oil vapour filter (Electronic motors)	900 hours ^{(3) (4)}
Check exhaust pipe/s for damage	Half-yearly
Impurity drainage/suction from the fuel tank	Half-yearly ⁽¹⁾
Change auxiliary member belt	1200 hours
Change air filter	1200 hours ⁽⁶⁾
Change coolant	1200 hours or 2 years

 Special maintenance	Frequency
Clean the turbocharger	1200 hours ⁽⁷⁾
Check the efficiency of the pre-post heating system (if available)	1200 hours
Injector calibration (Mechanical motors)	1800 hours
Overhaul injection pump (Mechanical motors)	3000 hours
Adjust play in valves-rocker arms	3000 hours

- 1) Maximum period when using good quality fuel, (EN 590 standard); this is reduced if the fuel is contaminated and alarms are triggered due to blockage of the filters and presence of water in the pre-filter. When blockage of the filter is indicated, it must be replaced. If the water in pre-filter indicator does not go out after drainage, the pre-filter must be replaced.
- 2) Refers to engines with traditional and automatic tensioning devices
- 3) Must be performed annually, even if the required number of working hours are not reached
- 4) Replace lubricants according to the frequency indicated in the REFUELLING table.
- 5) Only use filters with the following characteristics:
 - filtration level < 12 µm
 - filtering efficiency β > 200.

- 6) The frequency with which operations are carried out will depend on the working conditions and efficiency/wear of the product.
- 7) Required by oil vapour recirculation.

WARNING



The extraordinary maintenance operations described hereunder fall within the exclusive competence of manufacturer's personnel or specialised personnel having proper working tools and adequate protection devices. The procedure and modality for carrying out these operations are illustrated in the FPT Technical and Repair Manual.

REQUIREMENTS

1. Do not disconnect the batteries with the engine running.
2. Do not carry out arc welding operations in the vicinity of the engine without first removing electrical cables.
3. After each maintenance operation involving disconnection of the battery/batteries, make sure that the terminals have been properly locked onto the poles.
4. Do not use battery chargers to start the engine.
5. Disconnect the on-board network battery/batteries when recharging.
6. Do not paint the appliances, components and electrical connectors equipping the engine.
7. Disconnect the battery/batteries before any electrical operations.
8. Contact the Manufacturer before installing electronic equipment on board (two-way radios and the like).

WARNING

*Do not execute any operation which may change the ignition pump's calibration.
The ignition pump's calibration has been carried out in phase of engine system test based on its final use or destination.*

HOW TO PROCEED

Check oil level in engine

Only proceed with the engine stopped and at a low temperature, so as to avoid the risk of burning.

- ❑ Take all necessary action to ensure that the machine is "level".
- ❑ Using the dipstick (1), check that the oil level is between the "Min" and "Max" levels.
- ❑ If the level is too low, top up through the inlet, after first removing the relevant cap (2).

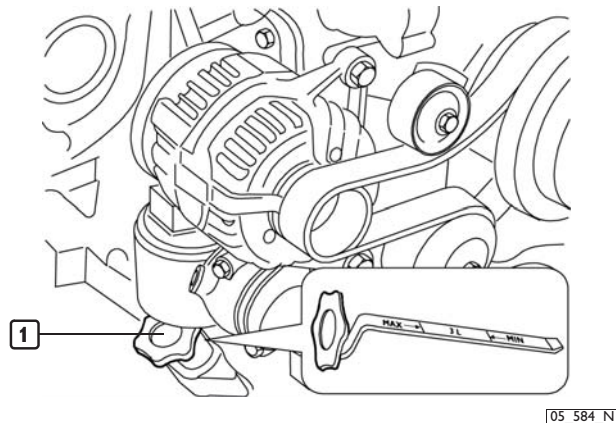
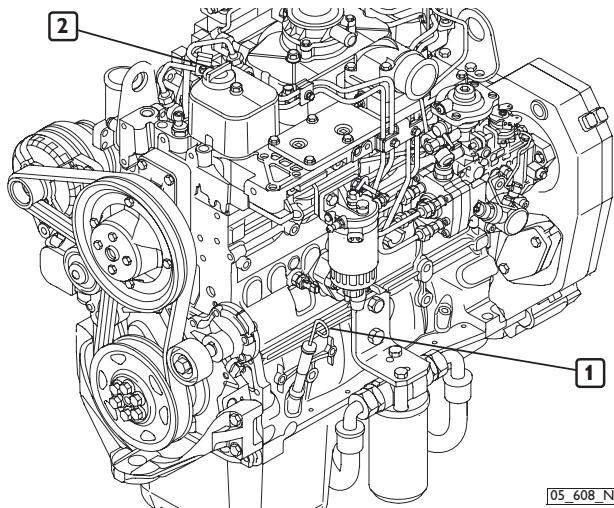

WARNINGS

- ❑ After topping up, make sure that the oil level does not exceed the "Max" limit marked on the dipstick.
- ❑ Make sure that the dipstick is inserted properly and the filler cap is turned in a clockwise direction until it stops turning completely.

Check coolant level

Proceed only with engine not running and at low temperature to avoid any risk of burns.

- ❑ With the engine at low temperature, make sure that the fluid level in the expansion tank is above the minimum level.
- ❑ Visually check that the fluid level is not more than 2/3 of the height of the tank in order to enable any increase in volume of the fluid caused by the temperature increase.
- ❑ Top up the tank if necessary, using clean water. Do not use distilled water; see the table REFUELLING.

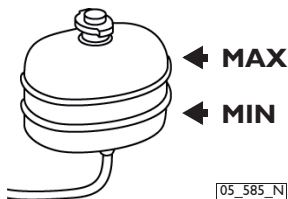

05_585_N

Note: If the refill operations occur frequently a diagnosis of the cooling circuit is necessary.

In the event that only the heat exchanger without the expansion tank is available on the vehicle, refill it if necessary, paying attention that the fluid does not saturate the internal volume of the exchanger in order to enable any increase in volume of the fluid caused by the temperature increase.

Clean heat exchangers

Check that the radiator air inlets are free from dirt (dust, mud, straw, etc.).

Clean them if necessary, using compressed air or steam.

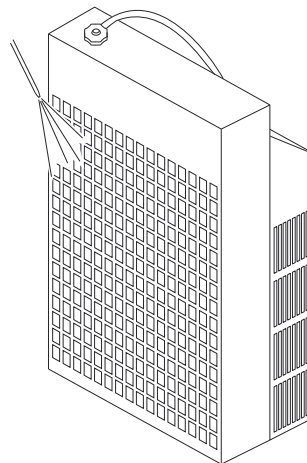

05_609_N

CAUTION!



When the engine is warm, a pressure liable to cause hot liquid to be expelled with extreme violence is created within the cooling circuits. This results in a danger of burning.

CAUTION!



The use of compressed air makes it necessary to use suitable protective equipment for the hands, face and eyes. Please see the prescriptions in the paragraph on ACCIDENT PREVENTION.

Cleaning the air filter

Only proceed with the engine stopped.

- ❑ Remove the filter cover (1) after first unscrewing the locking handle.
- ❑ Remove the external cartridge (2), after unfastening the second locking handle; during this operation, take care to ensure that no dust get into the sleeve.
- ❑ Check that there is no dirt. If there is, clean the filter element as indicated below.
- ❑ Blow dry compressed air through the filter element, from the inside outward (maximum pressure 200 kPa). Do not use detergents; do not use diesel.
- ❑ Never use tools to beat the filter element, and check its condition before replacing it.
- ❑ Replace the filter if any breakages or tears are found.
- ❑ Check that the gasket at its base is in good condition. Some filter systems are fitted with a second filter element (3) which does not require cleaning; this must be replaced at least once every 3 changes in the main element.
- ❑ Reassemble by repeating the above operations in reverse order.
- ❑ Set up the mechanical blockage indicator for operation by pressing the button located on the top part of the indicator. This operation is not necessary if there is an electrical sensor.

WARNING

Take care to ensure that the parts are reassembled correctly. Imperfect assembly might result in unfiltered air being sucked into the engine, causing serious damage.

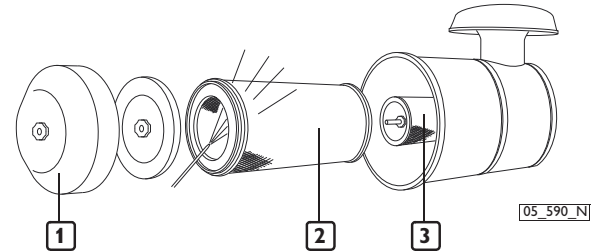

Drain water from the fuel filter/pre-filter

The high risk of refuelling with fuel that is polluted by foreign bodies and water makes it advisable to carry out this control every time you refuel.

Proceed with the engine stopped.

- ❑ Place a container under the filter or pre-filter to collect the fluid.
- ❑ Unscrew the tap plug (1) in the bottom part of the filter; in some lay-outs the plug includes a sensor to detect the presence of water in the diesel.
- ❑ Drain off liquid until only "diesel" can be seen.
- ❑ Close the plug again, tightening it completely by hand.
- ❑ Dispose of the drained fluids according to current requirements.

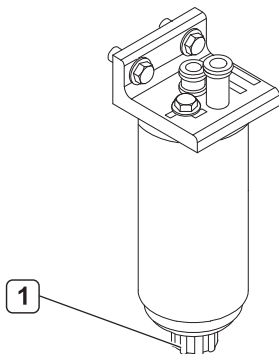

08_026_N

Check/top up electrolyte level in batteries

Place the batteries on a level surface, then proceed as follows.

- ❑ Visually check that the fluid level is between the "Min" and "Max" limits; in the absence of references, check that the fluid covers the Lead plates inside the elements.
- ❑ Top up with distilled water only those elements in which the level is below the minimum.
- ❑ Contact specialised technical staff if the battery needs recharging.
- ❑ Have the efficiency of the battery recharging system tested if a voltage of less than 11 V (for 12 V rated systems) or 22 V (for 24 V rated systems) is detected with the engine running.
- ❑ On this occasion, make sure that the terminals and clamps are clean, properly locked and protected by vaseline.

CAUTION!



- ❑ *The batteries contain sulphuric acid, which is extremely caustic and corrosive; always wear protective gloves and goggles when topping them up. Whenever possible it is recommended that this control be carried out by specialised personnel.*
- ❑ *Do not smoke or use live flames near the batteries during the control, and make sure that the room you are working in is adequately ventilated.*

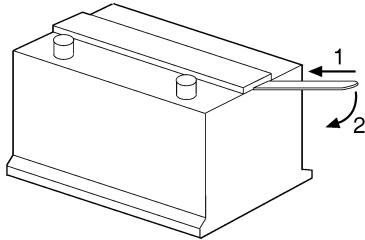

04_362_N

Some types of battery have a single cover for all the inspection plugs. To access the elements, use a lever as shown in the figure.

Check tension and state of the auxiliary member drive belt

Only proceed with the engine stopped and at a low temperature, so as to avoid the risk of burning.

Refers to engines with automatic tensioning devices

- Remove any casing protecting the pulleys.
- Check that the belt is not torn or worn, and that there are no lubricants or fuel on it. If this is not the case, replace them.
- At the same time, make sure that the tensioning device is working properly, proceeding as indicated in the figure.
- Replace the guard casing in its housing, and lock all the retaining elements.

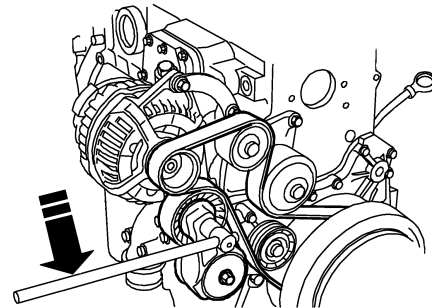

74178

Refers to engines with screw tensioning devices

❑ Check that the belt is not torn or worn, and that there are no lubricants or fuel on it. If this is not the case, replace them.

Should it be necessary to restore tension in the belt, proceed as follows:

- ❑ Loosen the screw fixing the alternator to the bracket (1).
- ❑ Loosen the bolt anchoring the alternator to its lower support.
- ❑ Proceed to tighten the tensioner (2), locking the counternut.
- ❑ On reaching the required tension, lock the fixing screws and bolt.

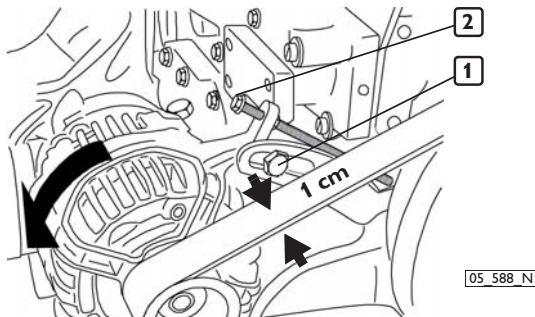

For engines without a screw tensioner proceed, after loosening the fixing screws (1) and anchor bolt, by turning the alternator as shown in the figure until the required tension is reached, after which tighten the fixing screws and anchor bolt firmly.

Replacing the oil vapour filter (N67 TE2A/TE1X/TE2X)

Only proceed with the engine stopped and at a low temperature, so as to avoid the risk of burning.

- ❑ Loosen the screws and remove the cover (1) of the filter housing.
- ❑ Remove the two filters and proceed to the replacement.
- ❑ Install the cover again.

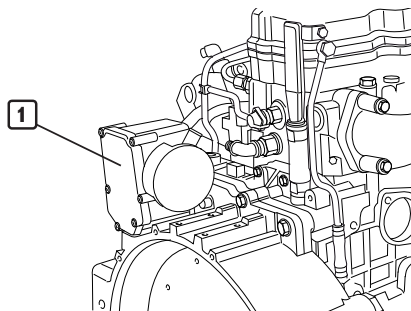

06_012_N

Change oil

Only proceed with the engine stopped and at a low temperature, so as to avoid the risk of burning.

- ❑ Place a container under the drainage plug to collect the used oil (see illustrations in the chapter ENGINE TECHNICAL DATA).
- ❑ Unscrew the plug and wait until the sump has emptied completely, then fasten the plug in place again.
- ❑ Fill up through the feeder hole (1) on the timer cover or elsewhere (opt.), using the types and amounts of oil indicated in the table REFUELLING.
- ❑ Using the dipstick (2), check that the oil level is between the "Min" and "Max" levels.
- ❑ Dispose of used oil according to current requirements.

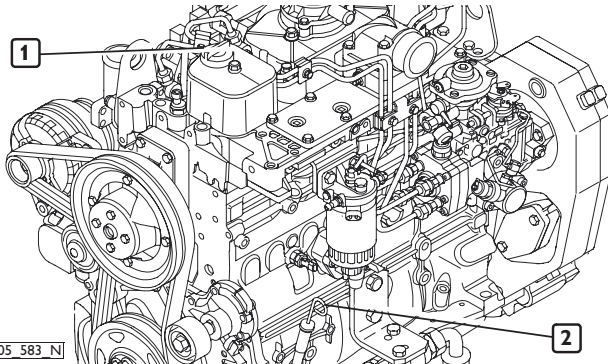

05_583_N

Change oil filter

Only proceed with the engine stopped and at a low temperature, so as to avoid the risk of burning.

Only use filters with a filtration level equivalent to the ones you are replacing (see section FREQUENCY).

- ❑ Place a container under the filter support (1), to collect the used oil.
- ❑ Unscrew the filter and remove it (2).
- ❑ Carefully clean the surfaces of the support that are in contact with the seal gasket.
- ❑ Damp the new seal gasket with a thin layer of oil.
- ❑ Hand screw the new filter into place until the seal gasket touches the support, then lock by a further 3/4 of a turn.
- ❑ Dispose of the old filter according to current requirements.

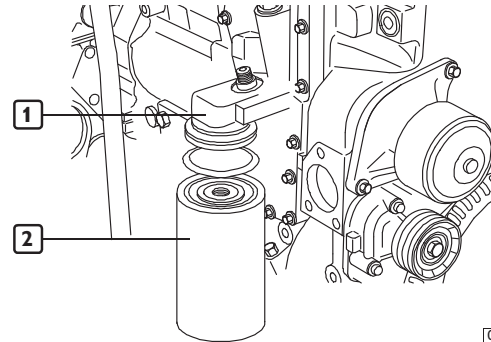

05_610_N

Change fuel filter/s

Only proceed with the engine stopped and at a low temperature, so as to avoid the risk of burning.

Only use filters with a filtration level equivalent to the ones you are replacing (see section FREQUENCY).

- ❑ Remove the filter/s (1) by unscrewing it.
- ❑ Check that the new filter has performance levels that satisfy the needs of the engine (e.g. by comparing them with the old one).
- ❑ Damp the new filter seal with diesel or engine oil.
- ❑ Hand screw the new filter into place until the seal gasket touches the support, then lock by a further 3/4 of a turn.
- ❑ Pay particular attention to the electrical fuel pre-heater (if available) and relevant electrical connection .

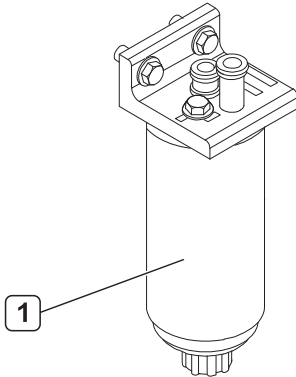

08_027_N

WARNING

Do not fill up the new filter before it is fitted to the support, to avoid inserting harmful impurities into the injection system and circuit.

Bleeding procedure (Mechanical motors):

- ❑ Loosen the fuel outlet manifold, located on the upper part of the filter (2).
- ❑ Make sure that any diesel coming out will not dirty the auxiliary member drive belt or be dispersed into the environment.
- ❑ Use the pre-filter hand pump until the diesel coming out is free from any residual air or perform the same operation using the mechanical feed pump (3).
- ❑ Lock the manifold loosened as above to the required torque.
- ❑ Dispose of any diesel expelled during the above operation in accordance with the law.
- ❑ Start the engine and run it at minimum speed for a few minutes to eliminate any residual air.

Note: Should it be necessary to accelerate the bleeding phase, the hand pump can be used during start-up.

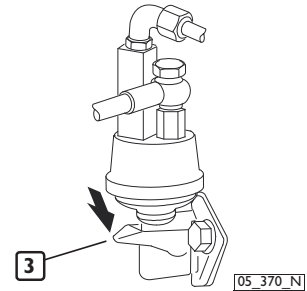

05_370_N

Changing the fuel pre-filter

Only proceed with the engine stopped.

- Should the filter be fitted with a sensor to detect the presence of water (3), remove the whole sensor from its seat.
- Remove the pre-filter by unscrewing it.
- Check that the new filter has performance levels that satisfy the needs of the engine (e.g. by comparing them with the old one).
- Damp the new filter seal with diesel or engine oil.
- Hand screw the new filter into place until the seal gasket touches the support, then lock by a further 3/4 of a turn.
- Place the water presence sensor in its seat, taking care to couple the threads correctly.
- Loosen the bleeder screw (1) on the pre-filter support and activate the hand pump (2) until the supply circuit is full. Ensure that any fuel coming out is not dispersed into the environment.
- Lock the bleeder screw tightly.
- Start the engine and run it at idle for a few minutes to eliminate any residual air.

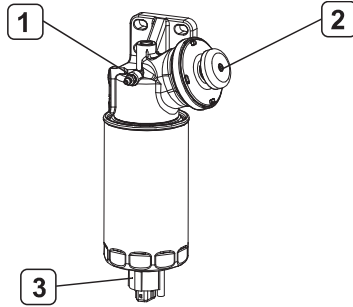

08_012_F

- Check the efficiency of the earthing connection of the filter support (4).

Note: Should it be necessary to accelerate the bleeding phase, the hand pump can be used during start-up.

Check exhaust pipe/s for damage

Visually check that the exhaust system is not blocked or damaged.

- Make sure that there is no risk of dangerous fumes within the machine. Contact the Manufacturer if necessary.

Impurity drainage or suction from fuel tank

Proceed taking into consideration the constraints of the tank's placement and structure.

The engines working in harsh environments and conditions and/or to be refuelled from cans or barrels require even more accurate tank cleaning.

Change auxiliary member belt

Please refer to the information provided for checking the belt tension.

Air filter replacement

Refer to the instructions provided for air filter cleaning.

Change coolant

Only proceed with the engine stopped and at a low temperature, so as to avoid the risk of burning.

- ❑ Provide suitable containers to ensure that no coolant is dispersed into the environment.
- ❑ Loosen the seal elements, remove the sleeves connecting the engine circuit to the heat exchanger and wait until it has emptied completely. When empty, repair the circuit making sure that the sleeves are perfectly sealed.
- ❑ Fill up the circuit as indicated in the table REFUELLING.
- ❑ Refill the engine and the heat exchanger until complete top up.
- ❑ With the filler cap open, start the engine and keep it idling for nearly one minute. This phase facilitates the cooling liquid air bleed.
- ❑ Stop the engine and top up again.

MOVING THE ENGINE

The operations necessary to disconnect and subsequently reconnect the engine must only be carried out by technicians from Service Centres.

When lifting the engine only, use the U-bolts indicated in this manual in the section ENGINE TECHNICAL DATA and marked on the engine with special stickers.

Lifting must be carried out using a rocker arm that keeps the metal cables supporting the engine parallel, using all the U-bolts provided simultaneously; the use of a single U-bolt only is not allowed.

The engine lifting system must have a capacity and size suited to the weight and dimensions of the engine; check that there is no interference between the lifting system and the engine components. Do not lift the engine before removing the transmission members that are coupled to it.

DISPOSAL OF WASTE

The engine is made up of parts and elements that, if discarded, may cause damage to the environment.

The materials listed below must be handed over to specialised Collection Centres; the laws in force in the various Countries foresee severe penalties for transgressors:

- ❑ Starter batteries.
- ❑ Used lubricants.
- ❑ Mixtures of water and antifreeze.
- ❑ Filters.
- ❑ Additional cleaning materials (e.g. greasy or fuel-soaked cloths).

■ LONG PERIODS OF INACTIVITY

PREPARING THE ENGINE FOR A LONG PERIOD OF INACTIVITY

In order to prevent oxidation of the internal parts of the engine and of certain components in the injection system, when the engine is expected to be inoperative for periods of more than two months, the following operations must be carried out in preparation for this:

1. Drain the lubricant from the sump, after first warming up the engine.
2. Fill the engine with protective oil type 30/M (or alternatively oil that complies with MIL 2160B type 2 specifications), up to the "minimum" level indicated on the dipstick. Start the engine and keep it running for approximately 5 minutes.
3. Drain the fuel from the injection circuit, from the filter and from the injection pump pipes.
4. Connect the fuel circuit to a tank containing CFB (ISO 4113) protective fluid, and feed in the fluid by putting the circuit under pressure and running the engine for approximately 2 minutes, after first disabling the injection system. This operation can be performed by polarising terminal 50 of the starter motor with a positive voltage equivalent to the rated voltage of the system, using a conductor provided for that purpose.
5. Nebulise approximately -- g of 30/M protective oil (10 g per litre displacement) into the turbocharger suction inlet, during the pressurised filling operation described in the previous point.
6. Close all the suction, delivery, ventilation and bleeder openings in the engine with suitable plugs, or seal them with adhesive tape.
7. Drain the residual 30/M protective oil from the sump. This oil can be used again for a further 2 preparation operations.
8. Fit signs reading "ENGINE WITHOUT OIL" to the engine and to the on-board control panel.
9. Drain the coolant, if it has not been mixed with suitable antifreeze and corrosion inhibitors, and affix a sign to indicate the fact.

In the event of prolonged inactivity, the operations described must be repeated every 6 months, following the procedure given below:

- A) drain the 30/M protective oil from the sump;
- B) repeat the operations described from point 2 to point 7.

Should you intend to protect external parts of the engine, proceed by spraying OVER 19 AR protective liquid on unpainted metal parts, such as the flywheel, pulleys and the like, avoiding belts, connector cables and electrical equipment.

RESTARTING THE ENGINE AFTER A LONG PERIOD OF INACTIVITY

1. Drain the residual 30/M protective oil from the sump.
2. Fill the engine, as prescribed, with lubricant of the type and amount indicated in the table REFUELLING.
3. Drain the CFB protective fluid from the fuel circuit, carrying out this operation as indicated under point 3. of PREPARING THE ENGINE FOR A LONG PERIOD OF INACTIVITY.
4. Remove the plugs and/or seals from the suction, delivery, ventilation and bleeder openings in the engine, restoring it to a normal state of use. Connect the turbocharger suction inlet to the air filter.
5. Connect the fuel circuits to the machine's fuel tank, completing the operations as indicated in point 4. of PREPARING THE ENGINE FOR A LONG PERIOD OF INACTIVITY. During filling operations, connect the fuel return pipe to a collection tank, so as to prevent any residual CFB protective fluid from flowing into the machine's fuel tank.
6. Check the engine and fill it up with coolant as prescribed, bleeding it if necessary.
7. Start the engine and keep it running until the idling speed rate has stabilised completely.
8. Check that the instruments on the on-board control panel/s are showing plausible values, and that no alarms are shown.
9. Stop the engine.
10. Remove the "ENGINE WITHOUT OIL" signs from the engine and from the on-board control panel.

■ ENGINE MALFUNCTIONS (N67 TE2A/TE1X/TE2X)

The electronic unit overseeing management and control of all operation of the engine is capable of recognising any malfunctions that may occur, and of adopting strategies that will allow you to proceed in full safety.

The event, signalled by light-up of the EDC MALFUNCTION indicator on the on-board control panels, results in programmed limitation of power within certain thresholds, set according to the severity of the case.

In the case of temporary malfunctions the reduction in performance will remain in force until the engine is stopped.

BEHAVIOUR IN CASE OF FAILURE

Accelerator electronic circuit malfunction

When certain problems in the accelerator electric circuit are recognised, the Electronic Unit controlling the engine adopts a strategy known as “accelerated minimum speed running”, that will enable running/work to continue in emergency mode.

The possible operating modes are as follows:

- A.** The accelerator lever does not “respond”: the running speed stabilises at 750 rpm. to allow the machine to proceed slowly and be manoeuvred simply by turning the inverter on and off, **without accelerating.**
- B.** The accelerator lever “responds partially”: the minimum running speed is set to 750 rpm. When the accelerator lever is moved to approximately half way, the speed gradually increases up to 2000 rpm.; when the lever is returned to minimum the speed rapidly decreases to 750 rpm.

Malfunction in the recharging system

The Electronic engine control units are programmed to increase the minimum running speed if the voltage in the electrical system reaches values considered to be at the limits of efficiency. In this case, check the efficiency of the battery/ies and if necessary perform a check-up on the system components.

CAUTION!



The engine electronic control unit can adopt safety strategies at any time during use of the machine or vehicle, should conditions arise that are considered to put the engine at risk.

When conditions of this kind occur, proceed only if necessary and with the greatest possible care and attention.

CAUTION!



Do not leave vehicles or machines with the engine running without first putting the parking lock or brake on.

FAILURE CODE DECODING

G-Drive appliance

The emission of the anomaly codes detected during self-testing and stored in the ECU starts after pressing and releasing the BP1 push-button on the Interconnection Electrical Unit.

The LED LD1 will signal, with two series of emissions at different frequencies, the blink codes that indicate the anomaly with decimal numbering.

Slow blinks identify the area of the anomaly (engine, injectors, etc.), fast blinks identify a specific anomaly.

Every time the push-button is pressed and released, only one of the stored codes is emitted; therefore, the procedure must be repeated until an error indication identical to the first one is obtained, which means the entire error memory has been analyzed.

If no anomalies are stored, the light comes on when the push-button is pressed and comes off about 1 second after its release, without any subsequent blinking.

Blink Code

Someone of this codes are not significant in power unit appliance

Code	Failure signal origin
1 - 1	Vehicle speed signal
1 - 2	Multi-status programming
1 - 3	Cruise control / PTO commutators
1 - 4	Signal from accelerator pedal
1 - 5	Signal from clutch control
1 - 6	Non plausibility of brake activation sensors
1 - 7	Non plausibility of accelerator/brake activation sensors
1 - 8	Diagnosis warning light
1 - 9	Engine brake pre-selection controls
2 - 1	Cooling liquid temperature signal
2 - 2	Boosting air temperature signal
2 - 3	Fuel temperature signal
2 - 4	Boosting air temperature signal
2 - 5	Atmospheric pressure signal
2 - 6	Oil pressure signal
2 - 7	Oil temperature signal
2 - 8	Heater power stage on fuel filter
2 - 9	Pre-heating relay power stage

Code	Failure signal origin
3 - 7	Battery voltage
3 - 8	Pre-heating indicator power stage (LS)
3 - 9	Pre-heating monitoring signal *
4 - 2	Turbocharger impeller speed signal
4 - 3	Fuel limitation from VGT
4 - 4	Boost control
4 - 5	VGT control power stage (CC - HS)
4 - 6	Engine brake control power stage (HS)
5 - 1	Injector 1 control signal (according to combustion order)
5 - 2	Injector 2 control signal (according to combustion order)
5 - 3	Injector 3 control signal (according to combustion order)
5 - 4	Injector 4 control signal (according to combustion order)
5 - 5	Injector 5 control signal (according to combustion order)
5 - 6	Injector 6 control signal (according to combustion order)
5 - 7	C1 injectors driving power stage
5 - 8	C2 injectors driving power stage
6 - 1	Engine rev. /speed signal
6 - 2	Ignition phase signal
6 - 3	Non plausibility between crankshaft/timing shaft speed sensor signals

Code	Failure signal origin
6 - 4	Engine rev. /speed signal (overrun)
6 - 5	Power stage 8 for starting (HS)
6 - 6	Power stage 1 for TD-signal (SS)
6 - 8	Power stage 2 for synchronization signal (SS)
7 - 1	Speed limit switch control stage
7 - 2	CAN line network
7 - 3	Message from "Transmission Control" *
7 - 4	Message from ABS/ASR *
7 - 5	Engine brake warning light control stage
7 - 6	Oil pressure warning light control stage
7 - 7	Oil pressure sensor control stage
7 - 8	Engine temperature warning light control stage
7 - 9	Engine temperature indicator control stage
8 - 1	Rail pressure monitoring
8 - 2	Rail pressure signal
8 - 3	Power stage for fuel pressure control (CC - HS)
8 - 4	Safety valve monitoring (pressure)
8 - 5	Excessive/insufficient pressure in rail
8 - 6	Power stage for EGR control (CC - HS)
8 - 7	Signal from intake air capacity meter

Code	Failure signal origin
8 - 8	Ambient temperature signal
9 - 3	Immobilizer
9 - 4	ECU supply main relay
9 - 5	Tachograph signal
9 - 6	ECU enabling or disabling procedures
9 - 7	Sensor supply
9 - 8	Message from Body Computer *

Combustion order of 4-cylinder engines: 1-3-4-2

Combustion order of 6-cylinder engines: 1-5-3-6-2-4

*) Not included in the release of May 2003.

■ BEHAVIOUR IN AN EMERGENCY

The user of a machine that has been constructed according to safety regulations, when following the instructions provided in this manual and the indications given on the engine labels, will be working in safe conditions.

Should improper conduct result in accidents, always request the intervention of trained first aid specialists immediately.

In an emergency and while awaiting the arrival of first aid specialists, follow the instructions given below.

Engine malfunctions

When operating with a malfunctioning engine, take the greatest possible care when manoeuvring and make sure that all those aboard are holding firmly to safe hand-holds.

In case of fire

Extinguish the fire using the fire-fighting equipment foreseen, and in the manner indicated by Fire prevention authorities (fire-fighting equipment for certain machines and equipment is compulsory under current safety legislation).

Burns and scalds

1. Extinguish any flames on the burned person's clothing, by:
 - throwing water over them;
 - using a powder fire-extinguisher, without directing the jet at the person's face;
 - covering with blankets or rolling the victim on the ground.

2. Do not attempt to remove pieces of clothing that may have stuck to the skin;
3. In the case of scalding, immediately but carefully remove any clothing that may be soaked in the hot liquid;
4. Cover the burn with a special burn dressing or sterile bandage.

Carbon monoxide intoxication (CO)

Carbon monoxide from the engine exhaust is without smell, and is dangerous both because it causes intoxication, and because when combined with air it forms an explosive mixture.

In closed rooms, carbon monoxide is extremely dangerous, as it can reach critical concentrations within a very short time.

When assisting an intoxicated person in a closed room:

1. Ventilate the room immediately, to reduce the concentration of gas.
2. When entering the room, hold your breath, do not light flames, lights or ring electric doorbells or phones, to avoid the risk of explosion.
3. Carry the intoxicated person out into the fresh air or into a well ventilated room, resting him on one side if he is unconscious.

Electrocution

- A.** The engine's electrical 12 V or 24 V electrical system does not involve the risk of electrocution, however, in the event of a short-circuit caused, for example, by a metal tool, there is a risk of burning due to overheating of the object through which the electrical current runs. In these circumstances:
1. Remove the object that caused the short-circuit, using means that provide sufficient heat insulation.
 2. Switch off the power at the main switch, if there is one.
- B.** The electric generator systems (generator units) normally produce high voltages that are liable to result in extremely dangerous current levels. In the event of medium or high voltage electrocution:
1. Turn off the power supply at the main switch before touching the victim. If this is not possible, use equipment that is both safe and adequately insulated when touching the victim; remember that touching a victim of electrocution is also extremely dangerous for the person giving aid.
 2. Proceed as indicated by the competent authorities (cardiac massage, mouth-to-mouth resuscitation, etc.)

Injuries and fractures

The vast number of possible circumstances and the specific nature of operations required means that the intervention of a medical team is necessary.

1. In the event of bleeding, keep the edges of the wound pressed together until help arrives.
2. If there is any suspicion of a fracture, do not move the injured part and only move the patient if absolutely necessary.

Caustic burns

Caustic skin burns are caused by contact with extremely acid or alkaline substances.

For electric maintenance technicians these are typically caused by acid from batteries; in these circumstances, proceed as follows:

1. Remove any clothing soaked in the caustic substance.
2. Wash the area with lots of running water, avoiding parts that have not been burned.

If either battery acid, lubricants or diesel come into contact with the eyes: wash the eyes with water for at least 20 minutes, keeping the eyelids open so that the water flows over the eyeball (move the eye in all directions to wash more thoroughly).

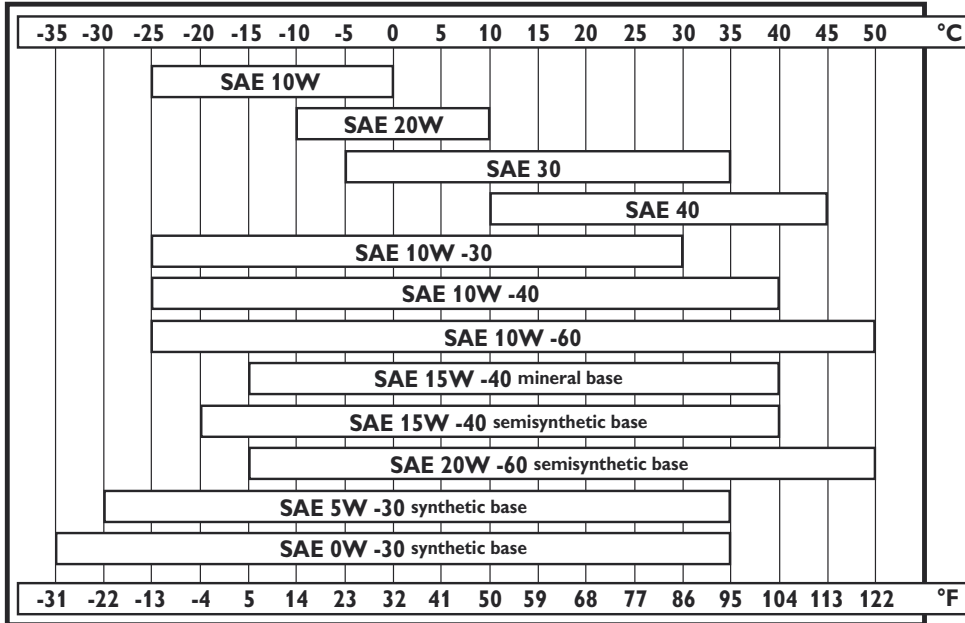

ELECTRONIC CONTROL PANEL USE REQUIREMENTS

The data indicated below refer to FPT equipment in its original configuration.

The requirements and technical characteristics of the customisations may differ from those indicated and must be dealt with in a specific document prepared by those who have performed any such customisations.

FPT control panels	With analogue instruments	With digital instruments
Environmental working conditions		
Operating temperature range	from -10°C to +60°C	from -10°C to +60°C
Temperature limits during stationing	min. -20°C / max. +75°C	min. -20°C / max. +75°C
Degree of protection against dusts and rain (front)	IP 65 – DIN 40050 – IEC 529	IP 66
Saline mist resistance (Reference standard)	IEC 60068-2-52	IEC 60068-2-52
Electric and electromagnetic characteristics		
Operating voltage (excluding polarity inversions)	min. 9 V / max. 32 V (*)	min. 9 V / max. 32 V (*)
Maximum allowed overvoltage	60 V per 1 ms	60 V per 1 ms
Maximum allowed current on main control panel	1.1 A (12 V) – 1 A (24 V)	310 mA (12 V) – 200 mA (24 V)
Maximum allowed current on secondary control panel	400 mA (12 V) -400 mA (24 V)	310 mA (12 V) -200 mA (24 V)
Electromagnetic compatibility (Reference standard)	IEC 945	IEC 945
Wiring connector requirements (Reference standard)	MIL 1344/1001	MIL 1344/1001
Wiring requirements (Reference standard)	CEI 20/22 - CEI 20/38 - CEI 2000/532/CE	
Mechanical characteristics		
Vibration resistance (expressed as gravity acceleration)	1 g eff. max. -25-500 Hz	2 g eff. max. -25-500 Hz
Shock resistance (expressed as gravity acceleration)	15 g - 1.5 ms - semisinusoidal wave	15 g - 1.5 ms - semisinusoidal wave

(*) min. 9 V / max. 16 V referring to the equipment designed to be supplied only at the rated voltage of 12 V.