



950106-01352

Operation & Maintenance Manual

GENERATOR DIESEL ENGINE

DP158LCF/LCS/LDF/LDS

DP180LBS/LAS/LBF/LAF

DP222LAS/LBF/LBS/LCF/LCS

3. Performance and specifications

Item		DP158L				Remarks
		DP158LCS	DP158LCF	DP158LDS	DP158LDF10	
No. of valve (per cylinder)	Intake	1				
	Exhaust	1				
Valve lashes (at cold) (mm)	Intake	0.25				
	Exhaust	0.35				
Intake valve (°)	Opening	24° (BTDC)				
	Close	36° (ABDC)				
Exhaust valve (°)	Opening	63° (BBDC)				
	Close	27° (ATDC)				
Electrical System						
Alternator voltage - capacity (V - A)		27.5 - 45				
Voltage regulator		Built-in type IC regulator				
Starting motor voltage - capacity (V - kW)		24 - 7.0				
Battery capacity		2-200Ah (recommended)				

Item		DP180L				Remarks
		DP180LBS	DP180LBF	DP180LAS	DP180LAF	
General Information						
Engine types		Water-cooled, 4cycle, V-type, Turbo charger & inter cooled (air to air)				
Cylinder liner type		Wet type liner				
No. of cylinder - bore x stroke (mm)		10 - 128 X 142				
Total displacement(cc)		18,273				
Compression ratio		15 : 1				
Rotation		Counter clockwise viewed from flywheel				
Firing order		1-6-5-10-2-7-3-8-4-9				
Injection timing (°) (BTDC)		21°±1°	19°±1°	21°±1°	19°±1°	
Dry weight (kg)		1,250				With fan
Dimension (L x W x H) (mm)		1,592 x 1,389 x 1,223				With fan
Flywheel housing		SAE NO.1M				
Flywheel		Clutch NO.14M				
No. of teeth on flywheel		160				
Cooling System						

3. Performance and specifications

Item	DP180L				Remarks	
	DP180LBS	DP180LBF	DP180LAS	DP180LAF		
Cooling method		Fresh water forced circulation				
Coolant capacity (L)	Engine only	Approx. 21				
	With radiator	Approx. 79 (Air on 43°C) / Approx 90 (Air on 52°C)				
Coolant flow rate (L /min)		660	550	660	550	
Pressure cap (kPa)		Max. 49				
Water temperature (°C)	Max. for stand by and prime	103				
	Before start of full load	40				
Water pump		Centrifugal type driven by belt				
Thermostat	Type	Wax-pellet type				
	Opening temp. (°C)	71				
	Full open temp. (°C)	85				
Cooling fan	Type	Blow Type				
	Diameter - blades	915mm - 7 blades				
Lubrication System						
Lubrication method		Fully forced pressure feed type				
Oil pump	Type	Gear type				
	Driving type	Driven by crankshaft gear				
Oil filter		Full flow, Cartridge type				
Oil capacity (L)	Max.	34				
	Min.	23				
Lubrication oil pressure (kPa)	Idle speed	Min. 100				
	Governed speed	Min. 250				
Max. oil temperature (°)		120				
Oil specification	Oil class	Above API CD				
	SAE	15W/40				
Fuel System						
Injection pump		Bosch in-line "P" type				
Governor		Electric type				

3. Performance and specifications

Item		DP180L				Remarks
		DP180LBS	DP180LBF	DP180LAS	DP180LAF	
Fuel feed pump	Type	Mechanical type injection pump				
	Capacity (L/hr)	630				
Injection nozzle	Type	Multi-hole (4 hole)				
	Opening pressure (MPa)	28				
Fuel filter		Full flow, Cartridge type with water drain valve				
Fuel Used		Diesel fuel oil				
Intake/Exhaust System						
Max. back pressure (kPa)		5.9				
Max. intake air restriction (kPa)	With clean filter element	2.16				
	With dirty filter element	6.23				
Cylinder block/head						
Valve system type		Overhead valve type				
No. of valve (per cylinder)	Intake	1				
	Exhaust	1				
Valve lashes (at cold) (mm)	Intake	0.25				
	Exhaust	0.35				
Intake valve (°)	Opening	24° (BTDC)				
	Close	36° (ABDC)				
Exhaust valve (°)	Opening	63° (BBDC)				
	Close	27° (ATDC)				
Electrical System						
Alternator voltage - capacity (V - A)		27.5 - 45				
Voltage regulator		Built-in type IC regulator				
Starting motor voltage - capacity (V - kW)		24 - 7.0				
Battery capacity		2-200Ah (recommended)				

Item		DP222L					Remarks
		DP222LAS	DP222LBS	DP222LBF	DP222LCS	DP222LCF	
General Information							
Engine types		Water-cooled, 4cycle, V-type Turbo charger & Inter cooled (air to air)					

3. Performance and specifications

Item	DP222L					Remarks
	DP222LAS	DP222LBS	DP222LBF	DP222LCS	DP222LCF	
Cylinder liner type	Wet Type					
No. of cylinder - bore x stroke (mm)	12 - 128 X 142					
Total displacement(cc)	21,927					
Compression ratio	15 : 1					
Rotation	Counter clockwise viewed from flywheel					
Firing order	1-12-5-8-3-10-6-7-2-11-4-9					
Injection timing (°) (BTDC)	21°±1°	21°±1°	19°±1°	21°±1°	19°±1°	
Dry weight (kg)	1,420					With fan
Dimension (L x W x H)(mm)	1,738 X 1,389 X 1,258					With fan
Flywheel housing	SAE NO.1M					
Flywheel	Clutch NO.14M					
No. of teeth on flywheel	160					
Cooling System						
Cooling method	Fresh water forced circulation					
Coolant capacity (L)	Engine only	Approx. 23				
	With radiator	Approx. 114 (Air on 43°C) / Approx 125 (Air on 52°C)				
Coolant flow rate (L/min)	660	660	550	660	550	
Pressure cap (kPa)	Max. 49					
Water temperature (°C)	Max. for stand by and prime	103				
	Before start of full load	40				
Water pump	Centrifugal type driven by belt					
Thermostat	Type	Wax-pellet type				
	Opening temp. (°C)	71				
	Full open temp. (°C)	85				
Cooling fan	Type	Blow Type				
	Diameter - blades	915mm - 9 blades				
Lubrication System						
Lubrication method	Fully forced pressure feed type					

3. Performance and specifications

Item		DP222L					Remarks
		DP222LAS	DP222LBS	DP222LBF	DP222LCS	DP222LCF	
Oil pump	Type	Gear type					
	Driving type	Driven by crankshaft gear					
Oil filter		Full flow Cartridge type					
Oil capacity (L)	Max.	40					
	Min.	27					
Lubrication oil pressure (kPa)	Idle speed	Min. 100					
	Governed speed	Min. 250					
Max. oil temperature (°C)		120					
Oil specification	Oil class	above API CD					
	SAE	15W/40					
Fuel System							
Injection pump		Bosch in-line "P" type					
Governor		Electric type					
Fuel feed pump	Type	Mechanical type injection pump					
	Capacity (L/hr)	630					
Injection nozzle	Type	Multi hole type					
	Opening pressure (MPa)	28					
Fuel filter		Full flow, Cartridge type with water drain valve					
Fuel Used		Diesel fuel oil					
Intake/Exhaust System							
Max. back pressure (kPa)		5.9					
Max. intake air restriction (kPa)	With clean filter element	2.16					
	With dirty filter element	6.23					
Cylinder block/head							
Valve system type		Overhead valve type					
No. of valve (per cylinder)	Intake	1					
	Exhaust	1					
Valve lashes (at cold) (mm)	Intake	0.25					
	Exhaust	0.35					

3. Performance and specifications

Item		DP222L					Remarks
		DP222LAS	DP222LBS	DP222LBF	DP222LCS	DP222LCF	
Intake valve (°)	Opening	24° (BTDC)					
	Close	36° (ABDC)					
Exhaust valve (°)	Opening	63° (BBDC)					
	Close	27° (ATDC)					
Electrical System							
Alternator voltage - capacity (V - A)		27.5 - 45					
Voltage regulator		Built-in type IC regulator					
Starting motor voltage - capacity (V - kW)		24 - 7.0					
Battery capacity		2-200Ah (recommended)					

3. Performance and specifications

Gross Engine Output

Engine Model			Performance				Remark
			Prime		Stand by		
			PS	kWm	PS	kWm	
DP158L	DP158LCS	60Hz (1,800rpm)	634	466	697	513	
	DP158LCF	50Hz (1,500rpm)	555	408	610	449	
	DP158LDS	60Hz (1,800rpm)	687	505	756	556	
	DP158LDF	50Hz (1,500rpm)	630	464	693	510	
180L	DP180LBS	60Hz (1,800rpm)	817	601	899	661	
	DP180LAS	60Hz (1,800rpm)	760	559	836	615	
	DP180LBF	50Hz (1,500rpm)	756	556	832	612	
	DP180LAF	50Hz (1,500rpm)	682	502	750	552	
DP222L	DP222LCS	60Hz (1,800rpm)	1,023	753	1,126	828	
	DP222LCF	50Hz (1,500rpm)	894	657	983	723	
	DP222LBB	60Hz (1,800rpm)	967	711	1,063	782	
	DP222LBF	50Hz (1,500rpm)	821	604	903	664	
	DP222LAS	60Hz (1,800rpm)	911	670	1,002	737	

3. Performance and specifications

Front/Rear(DP180L)

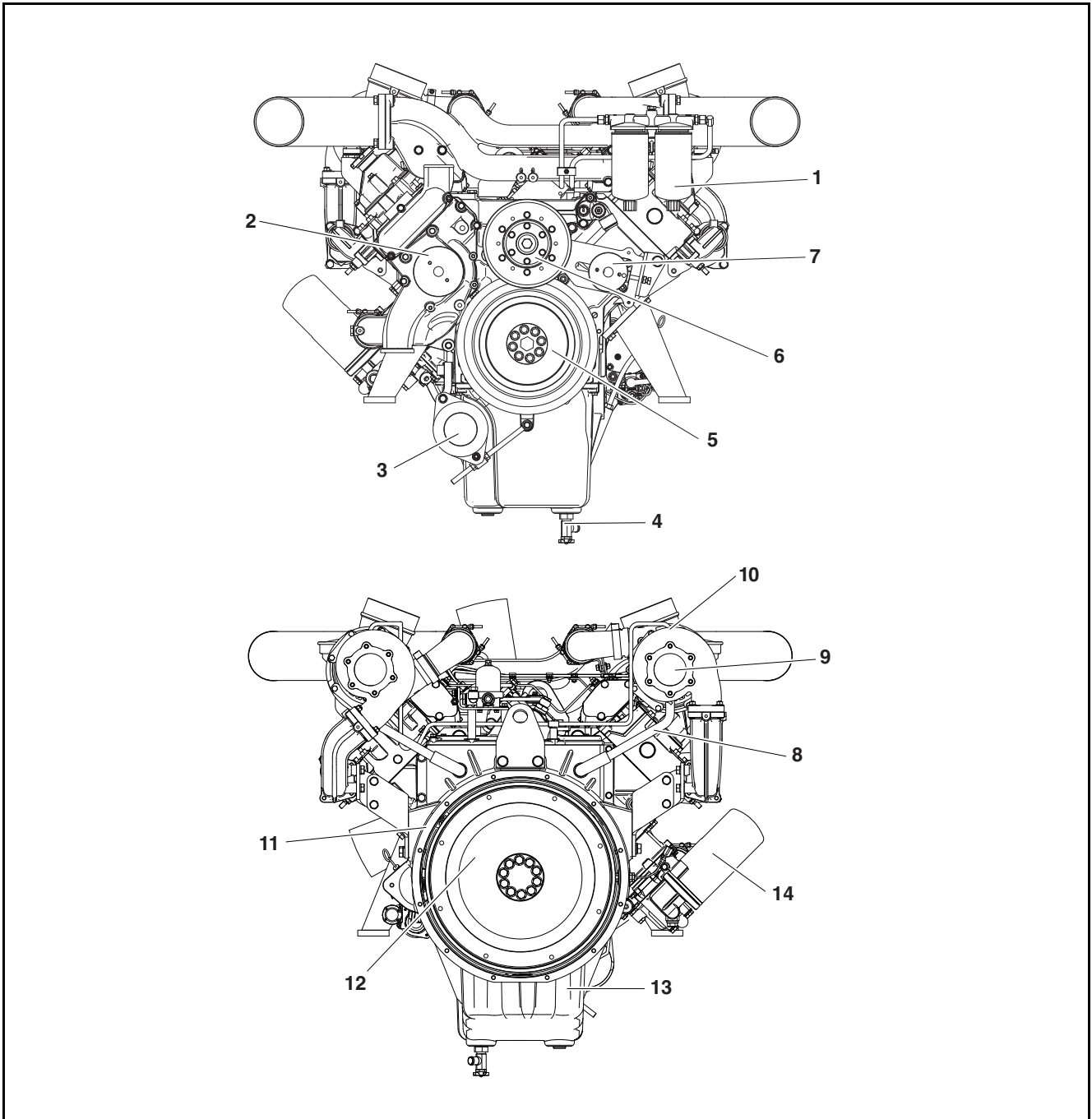

DV2213001B

- | | | |
|--------------------------|----------------------------|----------------------|
| 1. Fuel Filter | 6. Cooling Fan Pulley | 11. Flywheel Housing |
| 2. Coolant Pump | 7. Idle Pulley | 12. Flywheel |
| 3. Alternator | 8. Engine Oil Return Pipe | 13. Oil Pan |
| 4. Engine Oil Drain Plug | 9. Turbocharger | 14. Oil Filter |
| 5. Crankshaft Pulley | 10. Engine Oil Supply Pipe | |

3. Performance and specifications

Left/Right(DP180L)

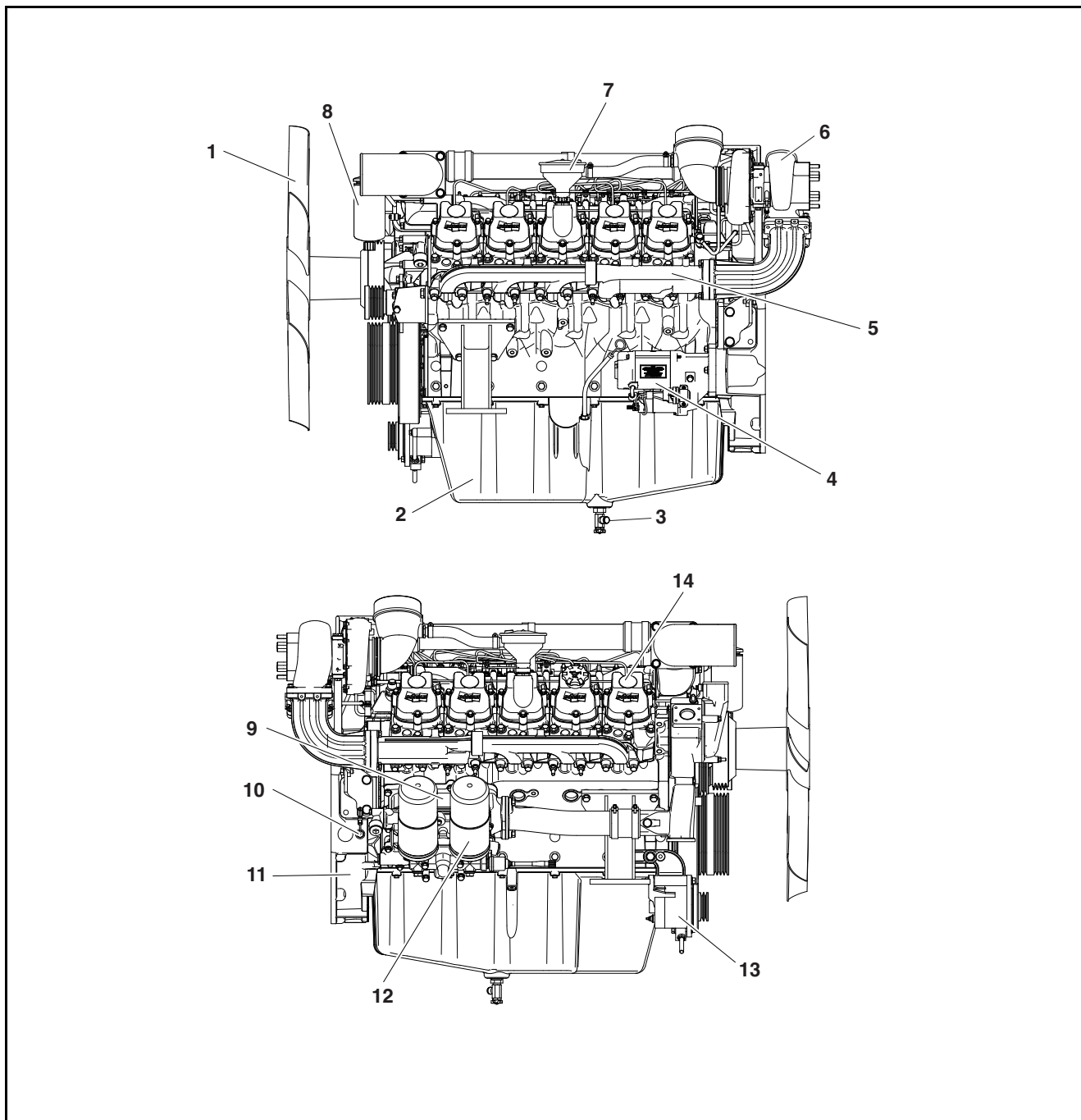

DV2213002B

- | | | |
|--------------------------|------------------|----------------------|
| 1. Cooling Fan | 6. Turbocharger | 11. Flywheel Housing |
| 2. Oil Pan | 7. Breather | 12. Oil Filter |
| 3. Engine Oil Drain Plug | 8. Fuel Filter | 13. Alternator |
| 4. Starter | 9. Oil Cooler | 14. Oil Cap |
| 5. Exhaust Manifold | 10. Tacho Sensor | |

3. Performance and specifications

Top(DP180L)

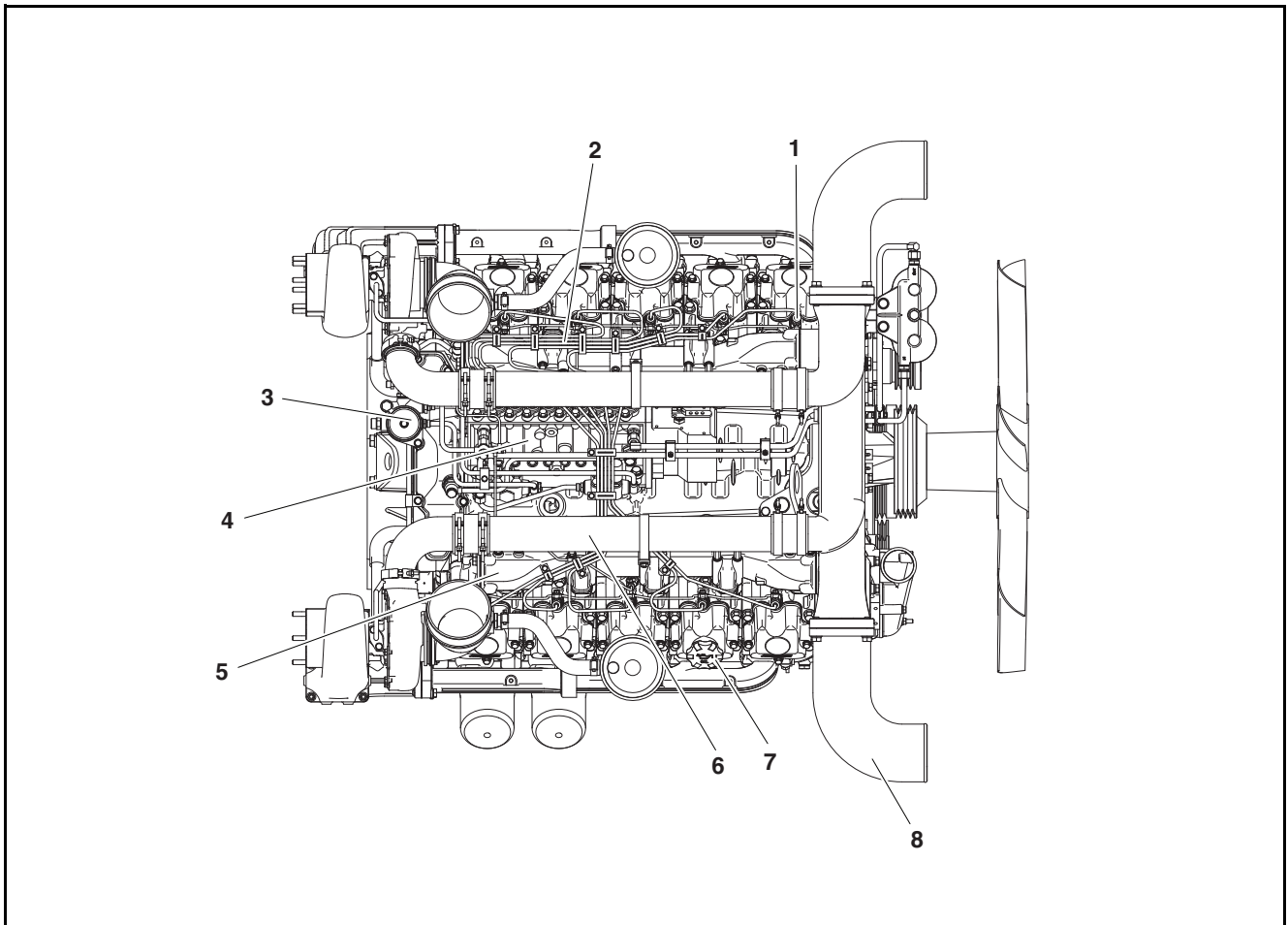

DV2213003B

- | | | |
|---------------------------------|------------------------|-------------------|
| 1. Injector | 4. Fuel Injection Pump | 7. Oil Filler Cap |
| 2. Fuel Injection Pipe | 5. Intake Manifold | 8. Inlet Pipe |
| 3. Fuel Pre-Filter/Priming Pump | 6. Intake Stake | |

3. Performance and specifications

Engine identification number

Engine Code and Manufacturing Number

The engine code and manufacturing number are engraved in the position marked (A) in the drawing. These numbers are necessary to request quality assurance or to order parts.

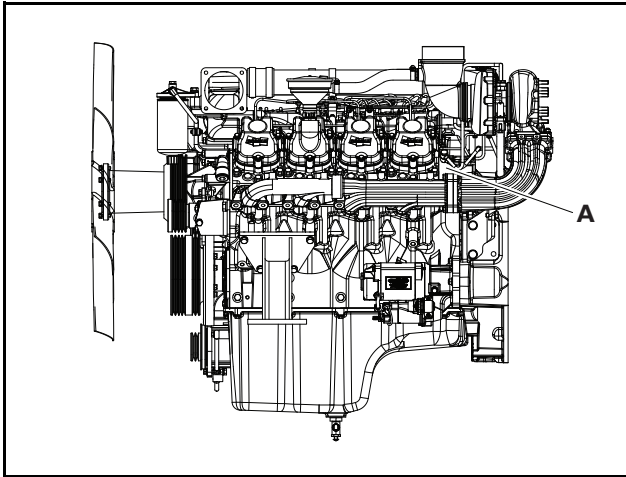

DV2213007A

Engine number engraving

• Type 1

□□□□□ □ □□□□□
(A) (B) (C)

- A. Engine model SUFFIX(5 digits)
- B. Production Year(1 digit)
- C. Serial Number(5 digits)

• Type 2

□□□□□□□ □ □□□□□□ □□
(A) (B) (C) (D)

- A. Sales Model name(4~7 digits)
- B. Production Year(1 digit)
- C. Serial Number(5 digits)
- D. After engine model SUFFIX(2 digits)

• Type 3

□□□□□ □□□ □ □□□□□□ □□
(A) (B) (C) (D) (E)

- A. Sales Model name(5 digits)
- B. Engine output(3 digits)
- C. Production Year(1 digit)
- D. Serial Number(5 digits)
- E. After engine model SUFFIX(2 digits)

• Type 4

□□□□□□□□□ □ □□□□□□
(A) (B) (C)

- A. New representative specification (9 digits)
- B. Production Year(1 digit)
- C. Serial Number(5 digits)

• Type 5

□□□□□□□□ □ □□□□□□ □□□□
(A) (B) (C) (D)

- A. Sales Model name(4~7 digits)
- B. Production Year(1 digit)
- C. Serial Number(5 digits)
- D. After new representative specification(3 digits)

• Type 6

□□□□□ □□□ □ □□□□□□ □□□□
(A) (B) (C) (D) (E)

- A. Sales Model name(5 digits)
- B. Engine output(3 digits)
- C. Production Year(1 digit)
- D. Serial Number(5 digits)
- E. After new representative specification(3 digits)

4. Regular inspection

General information	43
General Information	43
Routine Inspection	43
Regular inspection table	44
General Conditions	44
Use of Genuine Parts	45
Cooling system	46
General Information	46
Coolant standards	46
Capacity of coolant	46
Checking the Coolant	46
Measurement of Coolant Concentration	47
Discharging the coolant	48
Charging the Coolant	49
Cleaning the cooling circuit	49
Inter cooler	50
Lubrication system	51
General Information	51
Engine oil standards	51
Engine Oil Capacity	52
Checking the Engine Oil	52
Replacement of Engine Oil	53
Replacement of Engine Filter	53
Fuel system	54
General Information	54
Fuel Standards	54
Water draining from fuel filter	55
Replacing fuel filter	55
Preventing fuel contamination	56
Fuel injection pump	56
Cleaning the fuel pre-filter	56
Air bleeding in the fuel circuit	57
Injector maintenance	57
Fuel injection nozzle	57
Removal of nozzle	58
Installation nozzle	59
Note for cleaning nozzle	59
Checking the injection timing	59
Adjusting injection timing	60
Intake/exhaust system	61
General Information	61
Air Filter	61

Disassembly of air filter	61
Cleaning of the Air Filter Element	62
Changing the air filter element	63
Turbocharger	63
Routine check and serving the turbocharger	63
Disassembly and cleaning a turbocharger	63
Cylinder block/head	64
Valve Clearance	64
Adjusting the Valve Clearance	64
Tightening Cylinder Head Bolt	65
Cylinder Compression Pressure	66
Electric system	67
Battery	67
Starter	67
Others/driving system	68
V-Belt	68

General information

General Information

As time passes after purchasing an engine, each of the engines parts age and initial engine performance cannot be maintained.

Regular inspection and replacement according to the recommended regular inspection table allows you to maintain an engine with the optimum conditions and best performance for a long period and prevent unexpected accidents in advance.

Users are responsible for the proper operation and maintenance of engines. Engines should be inspected and replaced by officially-certified technicians in a workspace with the specified tools and facilities. Observe the following instructions to perform inspections.

1. Perform inspections on a flat floor without a slope.
2. Excluding extreme circumstances, only perform inspection while the engine is stopped.
3. Disconnect the '-' terminal of the battery before performing an inspection.
4. Perform inspection in a well ventilated space.
5. Use a wooden prop or lift when working under the engine.

DANGER

- **Wait until the engine is sufficiently cooled before starting inspection after operating the engine. Otherwise, you may be burned.**
 - **You may be poisoned by the emission when starting an engine in a closed space. Perform inspection at the well-ventilate space.**
 - **Unless absolutely compelled, do not perform inspection under an engine.**
 - **Do not be close to fire when inspecting an engine. Fuel, oil, or batteries may generate gas, causing fire.**
 - **If inspecting the engine while it is running, do not wear accessories such as necklaces, rings, watches or gloves. Such accessories may become stuck in rotating parts while the engine is running and may cause serious bodily injury.**
-

CAUTION

- **Incorrect inspection methods may cause of engine faults.**
 - **Cleaning an engine with liquids such as water or wax may cause breakdown of electrical parts.**
 - **Be careful when handling batteries, cables, and electrical wirings because current flows through those parts.**
 - **Do not put heavy things or apply excessive force or impact on the fuel-related units.**
 - **Make sure that you connect the battery terminal ('+' and '-') to the right terminal. Connecting the '+' and '-' terminals to the wrong terminal may cause damage to the electrical unit parts and fire.**
-

Routine Inspection

Routine inspection is an inspection performed by an engine operator before operating the engine. It should be performed to protect operator's safety, as well as the engine.

The following is a minimal check list.

1. Check whether the engine smoothly starts and the levels of fuel, oil, and coolant are within the normal range.
2. Check if any discharged emissions are colored and if the exhaust contains toxic gas elements.
3. Check whether abnormal noise occurs after starting an engine or not.
4. Check whether oil or water is leaking.

4. Regular inspection

Regular inspection table

General Conditions

Regular inspection and replacement according to the recommended regular inspection table allows you to maintain the engine with optimum conditions and best performance for a long period and prevent unexpected accidents in advance.

(○ : Inspection and Adjustment, ● : Replacement)

Check Points	Daily	Inspection interval (Hours)								Remark
		First 50	200	400	800	1,600	3,200	1Year	2Year	
Coolant system										
Check of coolant level	○									
V-belt tension, adjusting if necessary	○									
Check of coolant hose & clamp	○									
Concentration of antifreeze solution			○							
Replace V-belt						●			●	
Cleaning of water jacket and radiator								○		
Change of coolant								●		
Replace of coolant hose & clamp									●	
Lubrication system										
Check of engine oil level	○									
Engine exterior for loss of oil	○									
Oil Separator for oil leaks	○									
Change of Engine oil ^a		●	●					●		
Change of Oil Filter ^a		●	●					●		
Replace Oil Hoses, Clamps									●	
Intake/Exhaust system										
Check of exhaust gas color	○									
Check of air or gas leak	○									
Check of air cleaner indicator	○									
Clean of air filter element			○							
Replace air filter element				●						
Replace Air hoses, Clamps									●	
Fuel System										

4. Regular inspection

Check Points	Daily	Inspection interval (Hours)								Remark
		First 50	200	400	800	1,600	3,200	1Year	2Year	
Fuel lines for leaks	○									
Drain Fuel filter / Water separator	○									
Check of fuel stop lever	○									
Engine Clean fuel pre-filter		○		○						
Replace Fuel filter		●		●						
Replace Water separator filter		●		●						
Drain Water & Sediment from fuel tank				○						
Check of Injectors, replace if necessary ^a						○				
Replace Fuel Hoses, Clamps									●	
Electrical system										
Engine alarms	○									
Check of battery charging	○									
Magnetic pick up and adjust								○		
Cylinder head										
Cylinder head valve and valve seats							○			
Check of valve clearance										If necessary

a. If the sulfur content of fuel is > 0.02wt%, the changer or check intervals should be halved.

Use of Genuine Parts

An engine consists of many parts which are mechanically harmonized. To prevent engine faults in advance and use engines with best performance for a long period, maintenance and replacement of expendable parts should be conducted regularly.

Use of genuine parts is recommended. Using unauthorized or remanufactured parts may cause critical damage and faults to engine for which Doosan shall not be held liable.

4. Regular inspection

Cooling system

General Information

The coolant should be replaced according to the cycle specified in the inspection interval table. If the coolant gets dirty, the engine is overheated, and the coolant overflows in the thermal expansion tank.

Coolant standards

We recommend you to inject the antifreeze about 40~50% of the entire coolant. The antifreeze prevents the freezing and corrosion of the system, and increases the boiling point of water. In winter, you may need to change the amount of antifreeze per ambient temperature as shown in the table below. The freezing point per antifreeze ratio shown in the table may differ slightly depending on the antifreeze type. For more information, see the specifications provided by the manufacturer. Whenever you add coolant(water) to replenish the amount reduced by engine operation, the antifreeze portion is decreased. So, you need to increase the antifreeze level to the proper level after replenishing the coolant.

- concentration of antifreeze during winter

Ambient temperature (°C)	Coolant (°C)	Antifreeze (%)
Above -10	85	15
-10	80	20
-15	73	27
-20	67	33
-25	60	40
-30	56	44
-40	50	50

Capacity of coolant

Engine Mode	Coolant capacity (ℓ)	
	Inside engine	With radiator
DP 158L	About 20	About 79 (Air on 43°C)
		About 90 (Air on 52°C)

Engine Mode	Coolant capacity (ℓ)	
	Inside engine	With radiator
DP180L	About 21	About 91 (Air on 43°C)
		About 114 (Air on 43°C)
DP 222L	About 23	About 114 (Air on 43°C)
		About 125 (Air on 52°C)

Checking the Coolant

DANGER

If the radiator cap is opened to exchange or replenish coolant while the engine is overheated, hot water will spurt out and may cause serious burns. If it is absolutely necessary to open the radiator cap while the engine is overheated, wrap the radiator cap with a cloth and slowly open the cap in two steps until the steam pressure has been released from the inside. After the steam pressure has been completely released, remove the radiator cap.

1. For the engine coolant, you should use clean tap water.
2. To the engine coolant add 40% of antifreeze, and 3~5% of additive(DCA4) to prevent corrosion.
3. Periodically check coolant to maintain the concentration of antifreeze and additives.

DANGER

If you keep the antifreeze and corrosion inhibitor at a proper level, you can prevent the corrosion of engine effectively and keep the quality of the engine. Be careful that, if managed improperly, it can give a fatal impact on the coolant pump and cylinder liner.

4. The engine cylinder liner is of a wet type which specially requires good coolant flow.
5. You can check the concentration of antifreeze and corrosion inhibitor using the coolant test sheet.

4. Regular inspection

Measurement of Coolant Concentration

- Special Tools

Figure	Product Number/Name
	60.99901-0038 CC2602M Coolant test sheet

The coolant concentration can be measured as follows.

- If the engine coolant temperature is within a range of 10 ~ 55°C, drain the coolant and fill half a plastic cup with it.

CAUTION

When taking out a sample of coolant from the supplementary tank, it is difficult to measure the precise concentration. Always take out sample by opening the drain plug of coolant.

- Soak the test sheet in the coolant and take it out after 3 ~ 5 seconds. Shake the sheet to remove the remaining coolant.
- Wait for about 45 seconds until the test sheet changes its color.

CAUTION

Measurement time should not exceed 75 seconds.
The color changes as time passes.

- Check the color on test sheet.

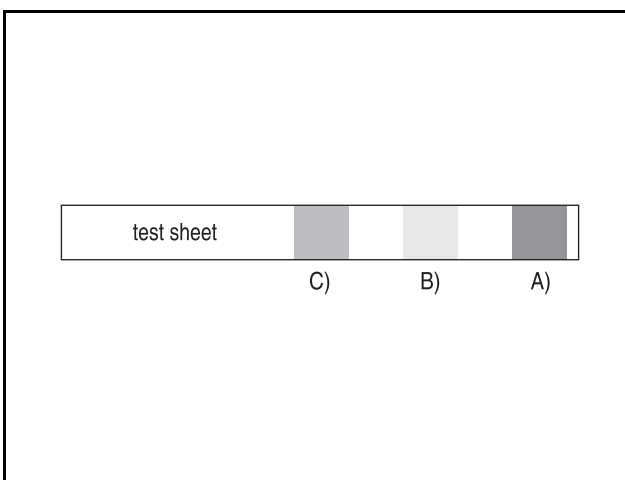

EDL0213002A

- Compare the color of part A on the test sheet to the color of GLYCOL/FREEZEPOINT (End pad) of the standard color table.
- Compare the color of the test sheet (B) to the color of MOLYBDATE (Middle pad) of the standard color table.
- Compare the color of the test sheet (C) to the color of NITRITE of the standard color table.
- Compare and confirm the parts with identical colors on the test sheet and the standard color table.

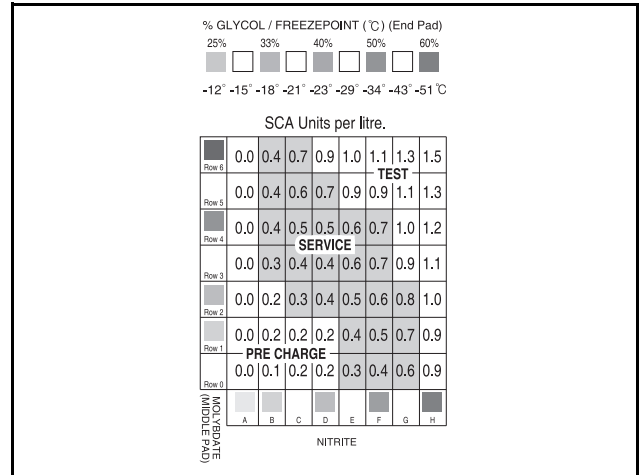

EDL022154A

- Compare the changed pink color part A of the test sheet with the GLYCOL/FREEZEPOINT (End pad) of the standard color table on top of the container and confirm the concentration. The concentration indication has to be within the color scope of 33~50%.
- The state of additives for anticorrosion is shown on the point where the color of MOLYBDATE (Middle pad) on the standard color table (which is identical with the Middle (B) of the test sheet) is crossed with the color of NITRITE on the standard color table (which is identical with the (C) of the test sheet). It should be maintained at the optimum range, in the green section between 0.3 to 0.8.

4. Regular inspection

- 3) If the measurement result is below 0.3, replenish anti-corrosion additives (DCA4). If it is above 0.8 or, drain a little coolant and then add clean tap water to adjust the concentration.

⚠ CAUTION

- If the color on the test sheet does not match the color of the standard color table, find a middle color on the standard color table. For example, if the color of (C) of the test sheet matches D and F on the NITRITE of the standard color table, select E.
- To prevent corrosion inside of the engine cooling unit, drain the coolant and replace it with new coolant once a year.

Discharging the coolant

The coolant can be discharged as follows.

1. Make sure that engine and radiator are cooled.
2. Open the radiator cap.

⚠ DANGER

- Never open the radiator cap while the engine is overheated. If the radiator cap is opened while the engine is overheated, hot water will spurt out and may cause serious burns. Open the radiator cap after ensuring that the engine has been cooled sufficiently.
- Mark and separately manage the containers for storing coolant from beverage containers to avoid confusion. If coolant is ingested, see a doctor immediately.

3. Loosen the drain valve which is located under the radiator to discharge the coolant.

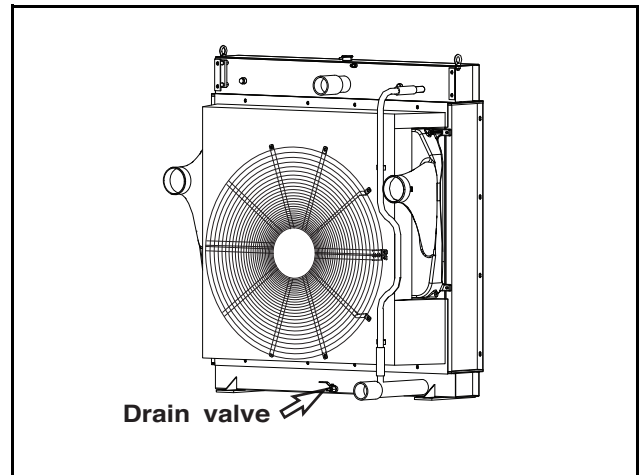

DV2213011A_E

4. Disassemble the coolant discharge plug of the cylinder block, and discharge it to a container.

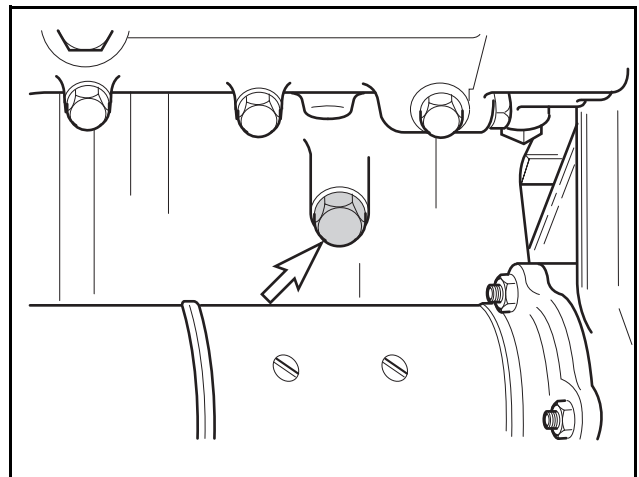

DV2213012A

5. Drain cooling water in the oil cooler.

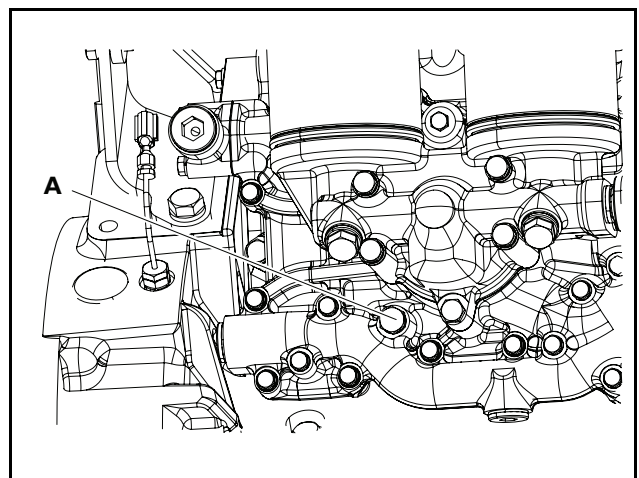

DV2213167A

- 1) Loosen the drain plug(A) of the oil cooler cover and then drain cooling water.

4. Regular inspection

Charging the Coolant

1. Make sure that engine is coolant.
2. Open the radiator cap.

DANGER

- Never open the radiator cap while the engine is overheated. If the radiator cap is opened while the engine is overheated, hot water will spurt out and may cause serious burns. Open the radiator cap after ensuring that the engine has been cooled sufficiently.
- Mark and separately manage the containers for storing coolant from beverage containers to avoid confusion. If coolant is ingested, see a doctor immediately.

3. Put in the coolant slowly.

CAUTION

Be careful not to let foreign substances flow into the engine when replenishing coolant.

4. Be sure that the air is gone out from cooling system.
5. After checking the coolant level when the engine is warmed up, replenish coolant if necessary.

DANGER

If the engine is hot, wrap the coolant pressure cap with a cloth upon opening it so that the steam may be discharged. This can prevent you from burning by the hot steam coming out of the cap inlet.

CAUTION

- Do not mix antifreezes from different manufacturers.
- Do not mix the coolant with different concentrations.
- Do not add antirust which is not recommended by us.
- As insufficient coolant concentration may cause corrosion or freezing, on the other hand, an excessive concentration may degrade the cooling performance. Mix coolant with 40% antifreeze and 3~5% additives (DCA4) to prevent corrosion.

WARNING

Discard exchanged coolant according to the regulations set forth by the relevant authorities. Disposing of exchanged coolant into the ground, sewers, drains, rivers, or the sea will cause serious environmental pollution. Violation of regulations regarding discard of coolant without observing the handling regulations, will be punished.

Cleaning the cooling circuit

If the internal coolant circuit is contaminated by corrosion or foreign substance, the cooling effect is reduced. The resistance in the coolant circuit may damage the mechanical seal of the coolant pump.

The negative impact on the cooling circuit may be caused by use of improper antifreeze or corrosion inhibitor, or by use of coolant without such ingredients. If the coolant pump leaks or the coolant is severely contaminated within short period of time (6 months) after start of using the operation (e.g., the coolant color becomes muddy - probably brown, gray or black depending on the degree of contamination), before removing the coolant pump, clean the cooling system in the following way.

1. Discharge the coolant.
2. If you want to clean the cooling circuit swiftly, remove the thermostat.
3. Mix water and 1.5% of cleaning solution and fill the cooling circuit with this liquid.
4. Load the engine. When the coolant temperature reaches 60°C, run the engine for about 15 minutes.
5. Discharge the cleansing solution.
6. Repeat the step 3 and 4 above.
7. Fill the cooling circuit with hot water.
8. While running the engine at idle speed for 30 minutes, check if there is any leakage in the drain plug and coolant line. If the coolant is insufficient, replenish it.

CAUTION

Clean the cooling circuit regularly with cleansing solution.

4. Regular inspection

Inter cooler

The air cooler adopts an air cooling fan, which has sufficient cooling capacity. The life and performance of an air cooler greatly depends on the intake air conditions. Dirty air may contaminate and clog the cooling pins. This results in reduced engine power or engine failure. So, always check the intake system for air leak, damage or contamination of air filter.

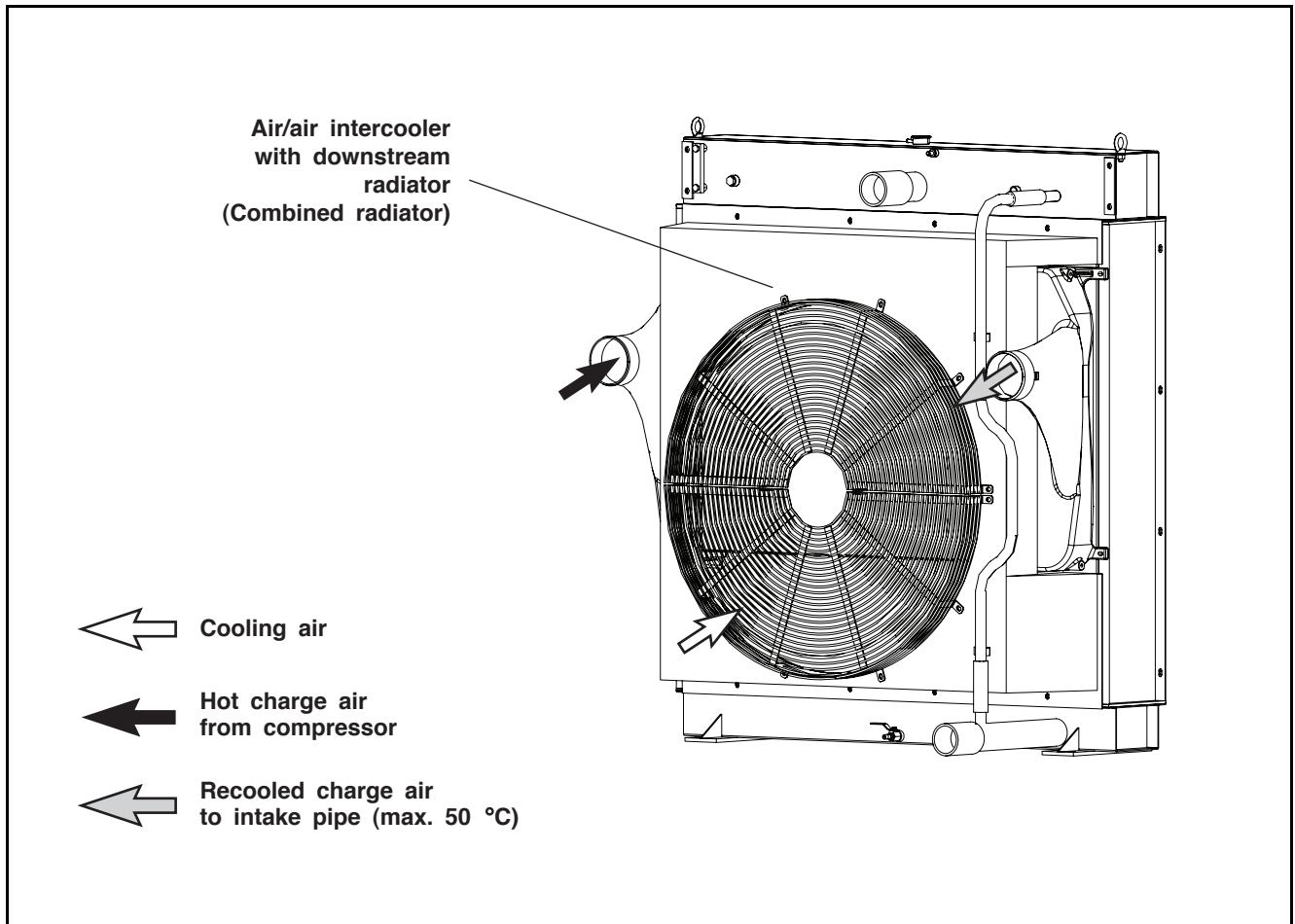

DV2213205B

CAUTION

To keep the optimum performance of the air cooler, clean it regularly.

4. Regular inspection

Lubrication system

General Information

Engine oil lubricates, cools, seals, prevents corrosion, and cleans engines, enhancing engine performance and extending the engine's lifetime. If a vehicle is continuously driven while engine oil is insufficient, the moving parts of the engine may get stuck, causing engine faults. Engine oil should be checked through the oil level gauge and replenished if required. Oil level should be checked while the engine is stopped. To check the oil level,

turn off the engine while it is running and wait for 5 ~10 minutes to allow the engine oil to flow back into the oil pan. The engine oil level should indicate between the upper limit and the lower limit of the oil level gauge. Engine oil should be periodically replaced based on the regular inspection table and the oil filter and the cartridge should be replaced as the engine oil is replaced.

Engine oil standards

Use the specified engine oil suitable for the environment and conditions of the site where the engine will be used.

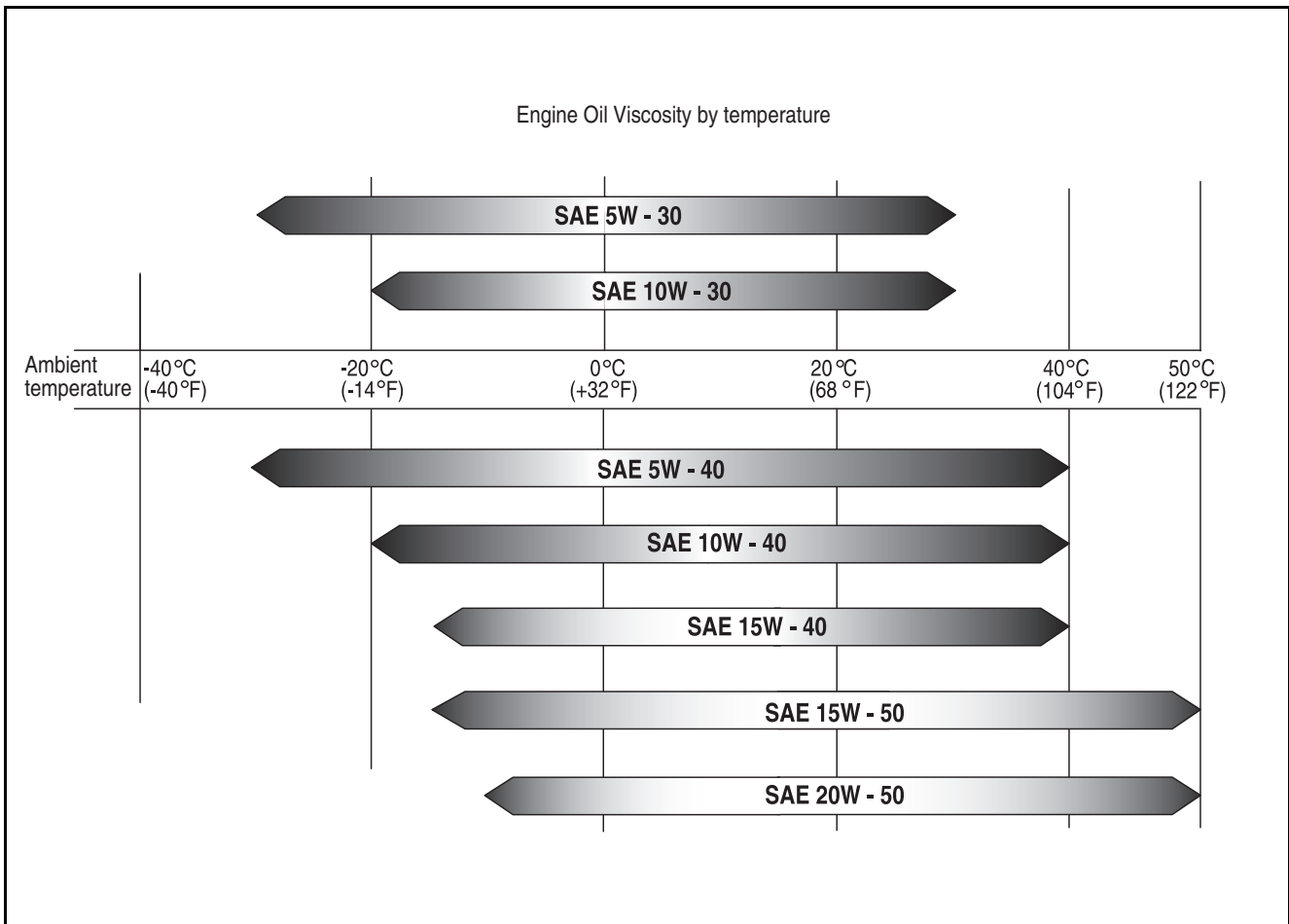

EDL0213001A

Please use the engine oil which satisfies the following recommended specifications.

Engine Model and Product Code	SAE Classification	Oil Class
DP 158L	SAE 15W40	API CD or above
DP180L	SAE 15W40	API CD or above
DP 222L	SAE 15W40	API CD or above

Note) Use of Doosan genuine engine oil is recommended.

4. Regular inspection

Engine Oil Capacity

Please replenish the engine oil based on the following recommended oil amount.

Engine Model	Engine oil capacity (ℓ)	
	Max.	Min.
DP 158L	22	13
DP 180L	34	23
DP 222L	40	27

Checking the Engine Oil

Check the oil level everyday using an oil level gauge.

1. The oil level should be checked when the engine is stopped and on an even level. If you started the engine, wait for 5~10 minutes to allow the engine oil to flow back into the oil pan.
2. Pull out the oil level gauge, and clean the indication line of the oil level gauge with clean cloth.

CAUTION

Cleaning the indication line of the oil level gauge with dirty cloth allows the foreign substances to get into the engine, causing damage to the engine.

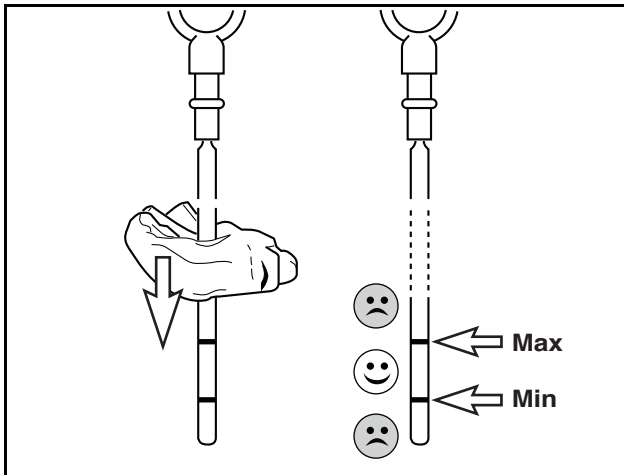

DV2213163A

3. Insert the oil level gauge, and then pull it out to check the engine oil level, viscosity, and contamination. Replenish or replace the engine oil if required.

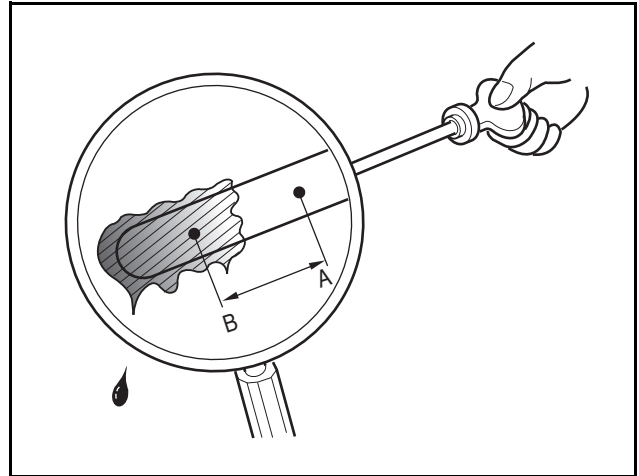

DV2213016A

- 1) Check the oil level everyday using an oil level gauge.
- 2) Check if the oil is smeared between the upper limit (A) and the lower limit (B) of the oil level gauge.
- 3) If engine oil is smeared below the lower limit (B) or not smeared on the gauge at all, replenish engine oil.
- 4) Check condition of engine oil. If it is polluted, replace it with new oil.

CAUTION

- Do not fill the engine oil above the upper limit. Exceeding the upper limit may damage the engine.
- Be careful not to let foreign substances flow into the engine when replenishing engine oil.

4. Regular inspection

Replacement of Engine Oil

Check the oil level using an oil level gauge and replenish it if required. Replace the engine oil in the following steps when the engine is warm by running it.

1. Pull out the oil level gauge.
2. Open the drain plug of the oil pan to discharge the engine oil from the container.

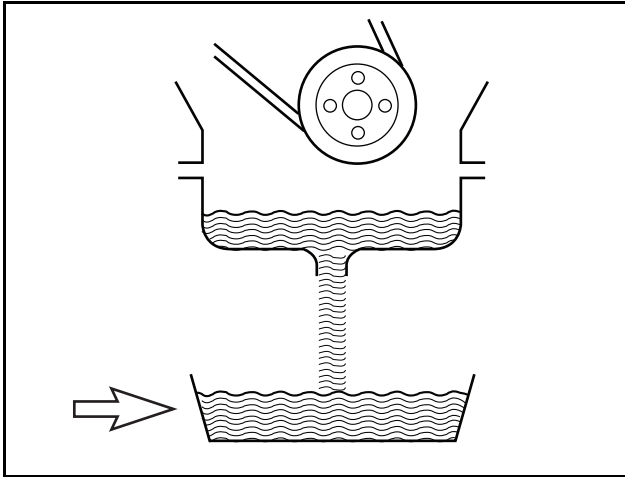

DV2213017A

3. After discharging the engine oil, assemble the drain plug of the oil pan again.
4. Fill the engine oil into the cartridge of the oil filter.
5. Through the oil filler cap, fill the engine oil.
6. Idle the engine for several minutes so that the oil circulate through the lubrication system.
7. Then, stop the engine, wait for about 10 minutes, check the oil level, and fill the oil if required.

DANGER

- Prolonged and repeated contact of skin with engine oil may lead to shrinking, dryness of skin and even cause dermatitis.
- Do not expose skin with exchanged engine oil for a long period.
- Always wear work clothes and gloves.
- When skin is stained with engine oil, immediately wash it with water, soap or hand cleaners.
- Do not clean skin with gasoline, fuel, thinner, or solvent.
- Apply a skin protective cream after cleaning from oil.
- Do not put oil-stained gloves or cloth in pockets.

WARNING

Discard exchanged oil according to the regulations set forth by the relevant authorities. Disposing of discharged oil into the ground, sewers, drains, rivers, or the sea will cause serious environmental pollution. Violation of regulations regarding discard of engine oil without observing the handling regulations, will be punished.

Replacement of Engine Filter

Check the oil pressure and leakage, and replace the oil filter if required. Whenever replacing the oil, the oil filter cartridge should be replaced with a new one.

1. Using an oil filter wrench, loosen the cartridge by turning it counterclockwise.
2. Wipe the oil filter head and cartridge contact thoroughly, and make sure that the oil filter cartridge is positioned properly.
3. Apply a little bit of oil to the o-ring area of the cartridge, assemble it until the O-ring surface may contact, and turn it 3/4 or 1 turn using a wrench to keep it air-tight.

CAUTION

When replacing the oil filter cartridge, be sure to use the genuine part of Doosan.

4. Regular inspection

Fuel system

General Information

The fuel injection pump and nozzle are composed of very sophisticated components with high precision. If fuel is mixed with foreign substance, it may clog the nozzle or the fuel injection pump components may be seized. So, be sure to keep the fuel system clean all the time.

CAUTION

- Use clean, certified and qualified fuel only. Using irregular or unspecified fuel may cause critical damage and faults to the engine.
- Replenish fuel while the engine is stopped.

Fuel Standards

The quality of fuel is very important to satisfy the engine performance, extension of engine life and the allowable exhaust gas level. Doosan engine is designed to use diesel fuel available in the local market. If you want the optimum engine performance, select the proper fuel referring to the fuel selection table below.

- Low Sulfur Diesel

Fuel Ingredients		Unit	Standard	Product
Specific Gravity		(kg/lit)	-	0.83
Flash Point		(°C)	> 40	47.8
Viscosity (40°C)		(cSt)	1.955	2.459
Sulfur content		(wt%)	< 0.05	0.038
Cloud point		(°C)	-	-3
Pour Point		(°C)	< -17.5	-27.2
Low temperature filter clogging point		(°C)	< -12	-18
Color (ASTM)			< 2.5	0.7
Carbon Residue (10%) Distillation residue (wt)		(%)	< 0.15	0.08
Total acid value		(mg KOH/g)	< 0.40	0.03
Copper corrosion (100°C, 3 hrs)			< 1	1 - a
Ash content (wt)		(%)	< 0.01	0.001
Moisture and Precipitate		(vol. %)	< 0.01	0.005
Cetane Index			> 45	52
Distillation test temperature	50% Distillation Point	(°C)	-	264.4
	90% Distillation Point	(°C)	< 360	344.3

Note) High sulphur content in diesel fuel Doosan diesel engines can be operated with fuels whose sulphur content is max. 0.05wt%. Fuels with a sulphur content of > 0.05wt% are not permitted as they result in increased corrosion and hence greatly reduce the service life of engines. The oil change intervals must be halved if the sulphur content is > 0.02wt%.

4. Regular inspection

Water draining from fuel filter

An oil filter has two functions: oil filtering and water separation.

1. the water separation function of the fuel filter discharges water and sediment from the water separator.
2. Stop the engine, and loosen the drain plug for water separation manually.

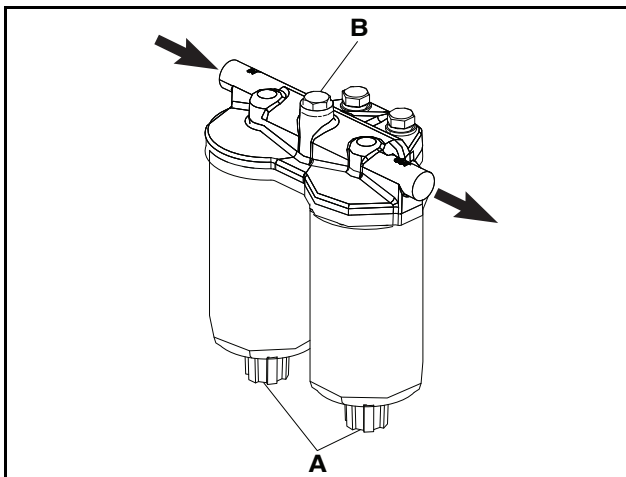

DV2213164B

3. Turn the drain plug (A) for water separation counter-clockwise 2~3times until water is drained. Drain the water in the cartridge until fuel is discharged.
4. Tighten the drain plug for water separation by turning it clockwise.

DANGER

Fuel may be drained when water is drained from the fuel filter. Fuel is highly inflammable. Fire may occur when you use fire near the engine when draining water from the fuel filter.

CAUTION

- Do not tighten the plug excessively because it may damage the screw.
- If you do not check the fuel filter regularly and drain the water in the fuel filter, water flows into the fuel system of the engine, causing serious failure in the fuel system, etc., and decrease in or damage to the fuel filter performance. Inflow of water to the fuel system may stop the engine.
- Use clean, specified, and qualified fuel only. using irregular or unspecified fuel may result in more water in the fuel filter.

Replacing fuel filter

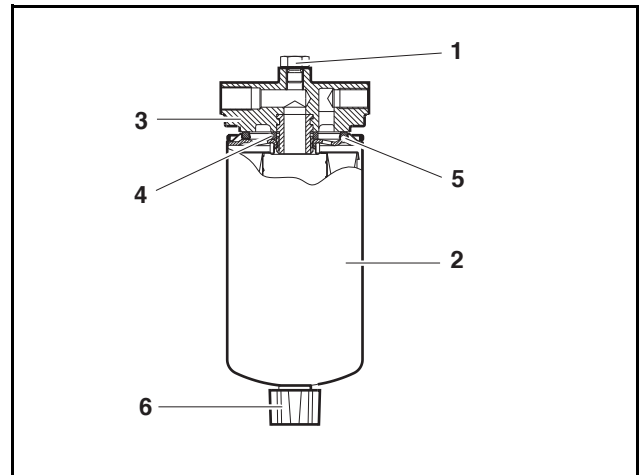

DV2213019A

1. Clean the area around the fuel filter head(3).
2. Disassemble the cartridge(2) by turning it counter-clockwise with a fuel filter wrench.

CAUTION

Do not reuse the cartridge; replace them with new ones.

3. Remove the fuel filter screw adapter seal ring(4).
4. Clean the gasket contact of the fuel filter head(3).
5. Check the position of the new cartridge adapter seal ring(4).
6. Apply thin coat of clean oil to the O-ring(5) area of the cartridge, and fill the cartridge with fuel.
7. Assemble the cartridge to the fuel filter head.
8. Tighten the cartridge with hand until the O-ring contacts the fuel filter head surface.

4. Regular inspection

9. Turn it by 3/4 to 1 turn with a fuel filter wrench.

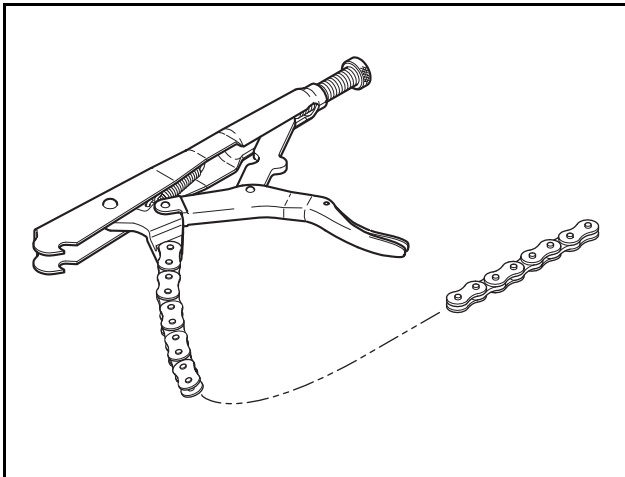

DV2213020A

⚠ CAUTION

If you tighten the cartridge excessively, the screw may be distorted or O-ring damaged.

Preventing fuel contamination

Most of the fuel contaminations encountered while using the alternator engine are caused by water and propagation of microbes.

Usually, the contamination results from improper handling of fuel. Propagation of microbes requires water contained in the fuel. To prevent propagation of microbes, you have to keep the water to the minimum level possible in the storage tank.

Fuel injection pump

- Check the fuel injection pump housing, and replace it if crack or damage is found.
- Check if the idle operation and speed control lever's sealing device was not removed.
- Check if the idling or speed control lever's sealing line is not damaged.
- You should not modify the fuel injection pump if the sealing line is damaged, such engine cannot receive compensation.
- If the fuel injection pump is found abnormal, authorized personnel should handle it.

- The adjustment and test of the fuel injection pump must be conducted using a tester.

⚠ CAUTION

If you separate the parts where the seal ring (copper seal ring, rubber coating seal ring, etc.) is assembled, you should replace the seal ring with a new one. Otherwise, leakage may occur in the fuel filter connections, preventing normal functioning.

Cleaning the fuel pre-filter

The fuel pre-filter should be cleaned periodically through disassembly. The fuel pre-filter is mounted individually for easy maintenance. Open the cover of the pre-filter and clean the element with compressed air first, and then rinse it with diesel fuel to remove foreign substances.

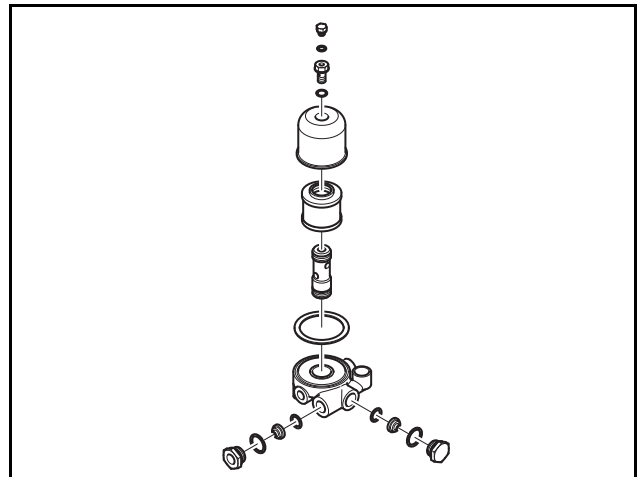

DV2213021C

4. Regular inspection

Air bleeding in the fuel circuit

When the engine stops due to replacement of fuel filter, fuel injection pump or insufficient fuel, you should perform air bleeding.

1. Loosen the air bleeding plug (B) on the fuel filter.
2. Operate the priming pump by hand to bleed air inside the fuel circuit.
3. Operate the priming pump until the air is discharged completely through visual checking.

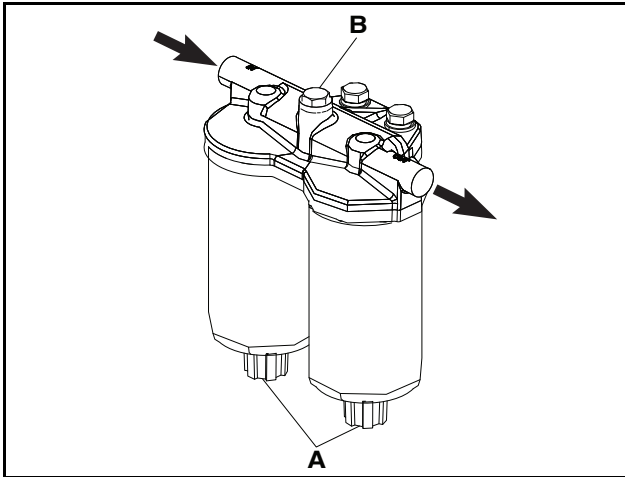

DV2213164B

DANGER

Fuel is highly inflammable. Fire may occur when you use fire near the engine when air bleeding in the fuel circuit from the priming pump.

CAUTION

If you separate the parts where the seal ring (copper seal ring, rubber coating seal ring, etc.) is assembled, you should replace the seal ring with a new one. otherwise, leakage may occur in the fuel filter connections, preventing normal functioning.

Injector maintenance

- The injectors are designed to spray the fuel delivered by the injection pump directly into the spherical combustion chamber in the piston crown.
- The injector consists of the nozzle and the nozzle holder.
- A copper gasket fitted to the injector ensures gas-tight seating and good heat dissipation.
- The opening pressure of the nozzle is adjusted by means of shims at the compression spring.

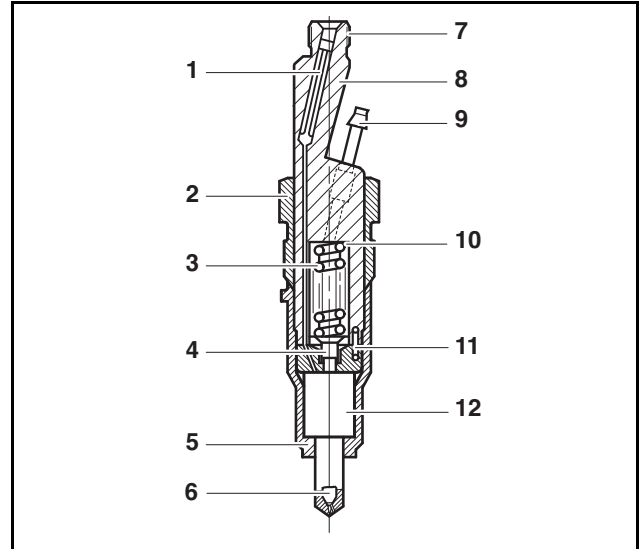

DV2213022A

- | | |
|-----------------------------|-----------------------------------|
| 1. Rod type filter | 7. Connect hole for fuel delivery |
| 2. Cap nut | 8. Nozzle holder |
| 3. Compression spring | 9. Connect tube for overflow |
| 4. Compression pin | 10. Shim |
| 5. Cap nut for fixed nozzle | 11. Pin |
| 6. Nozzle | 12. Nozzle bush |

Fuel injection nozzle

1. Install a nozzle to the nozzle tester.

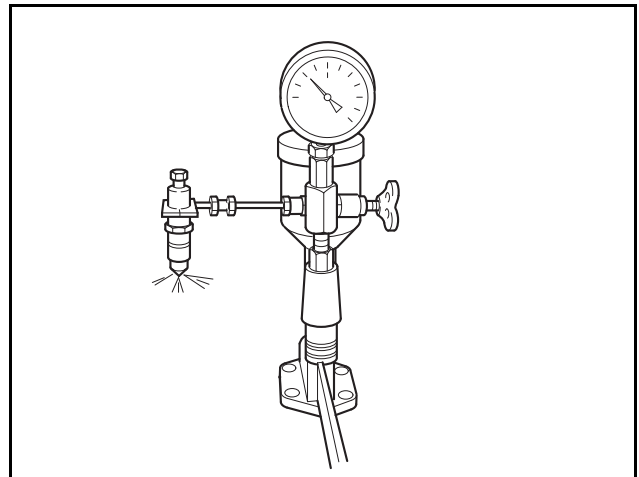

DV2213023A

2. Check the fuel injection pressure. If the pressure does not satisfy the reference value, adjust the injection pressure of the nozzle using an adjustment shim.

4. Regular inspection

3. Check the nozzle spray status. If it is defective, replace the nozzle.

CAUTION

- As the nozzle injection nozzle is designed to operate under high pressure, you should handle it with special care.
- Do not hold your hands under the fuel jet, as there is a rise of injury. Do not inhale the atomized oil fuel. If possible, work under an extraction system.

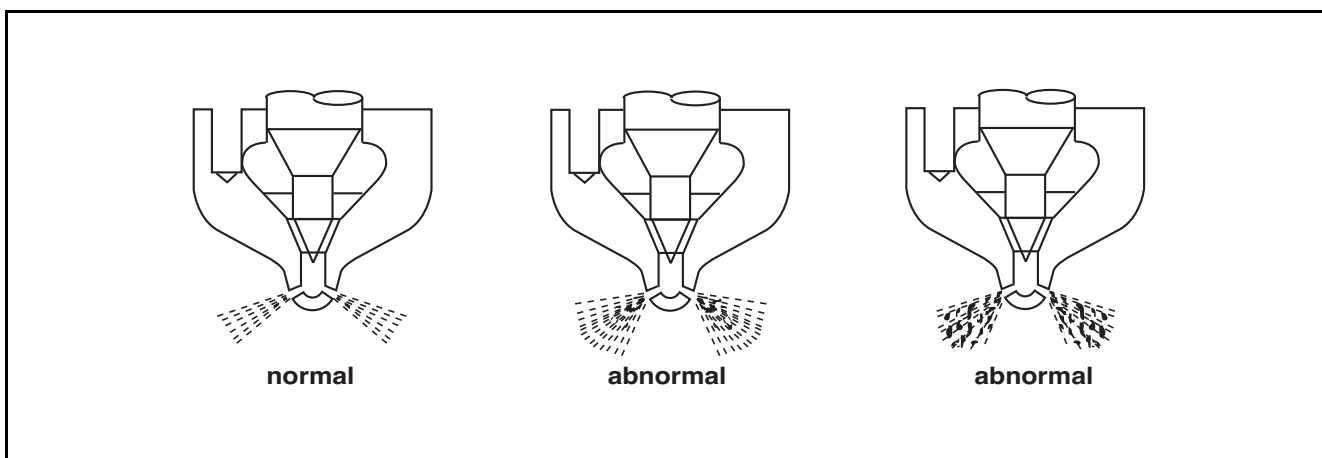

DV2213165A

Engine Model		Nozzle injection pressure (Mpa)
DP158L	DP158LCS	28
	DP158LCF	28
	DP158LDS	28
	DP158LDF	28
DP180L	DP180LBS	28
	DP180LBF	28
	DP180LAS	28
	DP180LAF	28
DP222L	DP222LAS	28
	DP222LBS	28
	DP222LBF	28
	DP222LCS	28
	DP222LCF	28

Removal of nozzle

1. Remove fuel injection pipe between nozzle holder and injection pump.
2. Remove fuel return pipe.
3. loosen the Union screw(A) of nozzle holder with Nozzle plug socket (EI.03004-0225)
4. Remove nozzle holder with sealing from the cylinder head.

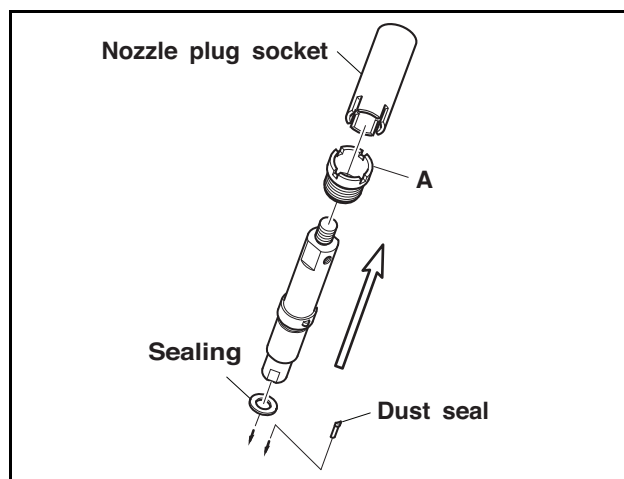

DV2213166B

4. Regular inspection

Installation nozzle

1. Clean seat in cylinder head.
2. Insert nozzle holder with new gasket.
3. Tighten union nut with 12 kgf·m.

Torque	12kgf·m
--------	---------

4. Install injection lines free of constraint. Install leak fuel lines, screw delivery pipe at nozzle holder and at the injection pump.

CAUTION

- The injection lines are designed for high operating pressure and should thus be handled with particular care.
- When mounting the pipes to the engine take care of good fitness.
- Do not bend pipes to permanent deformation. (not for replacing the nozzles either)
- Do not mount any heavily bent pipes.
- Avoid bending the pipes at the ends by more than 2 to 3 degrees.
- In case of faults in the injection system which might have resulted in excessive operating pressures, not only the failed part but also the injection line has to be replaced.

Note for cleaning nozzle

- Clean nozzle body externally from soot and carbon, When cleaning several nozzles at the same time, make sure nozzle bodies and needles are not mixed up. Visually inspect needle and body.
- Cleaning is useless if the seat of the needle is indented or the pintle is damaged and the nozzle should be replaced.
- Clean annular groove with scraper over full circumference. Wash out dislodged carbon deposits and dirt.
- Scrape needle seat with cleaning cutter, Dip cutter in test oil before use. The cutter can also be clamped in a lathe.
- Polish needle seat with wooden cleaning tool, preferably by chucking the needle in a lathe at the pintle end.
- Clean the spray holes of nozzles by chucking a cleaning needle of suitable diameter in the collect. If the carbon deposits in the spray holes cannot be removed by rotating and pressing, have the needle project only slightly from the collect and drive out the carbon by lightly tapping on the tool.

- Before reassembly thoroughly wash nozzle body and needle in clean test oil.
- Hold the needle at the pintle end only ; to avoid corrosion do not touch the lapped surfaces of the needle with you fingers.
- Thoroughly clean all other parts of the nozzle holder with clean fuel.
- Check nozzle discharge pressure in nozzle tester. The edge-type filter should not be pressed into the nozzle holder by more than about 5mm. If this depth is exceeded the injector must be replaced.

Checking the injection timing

1. Remove the plug screw on the flywheel housing cover.

Note) Some cases are needed to remove cover assembly.

2. Turn the crank pulley so that the mark on pointer provided on injection pump coincides with matching mark(FB) on the flange surface of the drive gear.

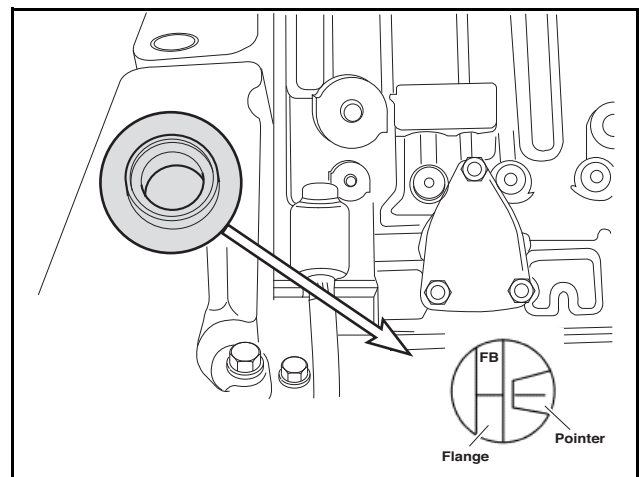

DV2213164A_K

4. Regular inspection

3. Check the injection timing degree whether the V-type edge of the flywheel housing sight hole coincides with the engine injection timing degree marked on the flywheel corresponding to fuel delivery position.

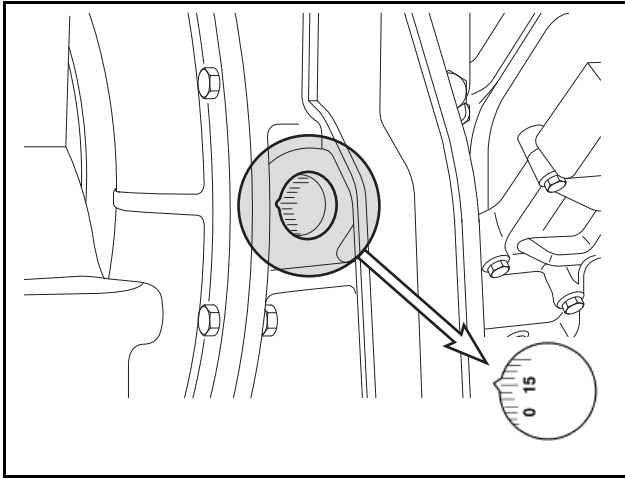

DV2213165A_K

Engine Model		Injection Timing (°)
DP158L	DP158LCS	23° ± 1°
	DP158LCF	18° ± 1°
	DP158LDS	23° ± 1°
	DP158LDF	18° ± 1°
DP180L	DP180LBS	21° ± 1°
	DP180LBF	19° ± 1°
	DP180LAS	21° ± 1°
	DP180LAF	19° ± 1°
DP222L	DP222LAS	21° ± 1°
	DP222LBS	21° ± 1°
	DP222LBF	19° ± 1°
	DP222LCS	21° ± 1°
	DP222LCF	19° ± 1°

Adjusting injection timing

If upper pre-checked injection timing degree is wrong, follow as below.

1. Loosen the fixing bolts(M8) of the injection pump driving gear in order to adjust the injection timing slightly.

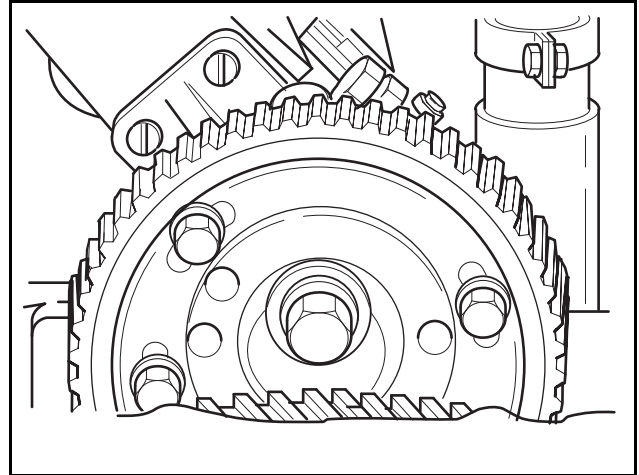

DV2213028A

2. Turn the crank pulley clockwise until V-groove of the flywheel housing sight hole is aligned with the injection timing degree of the engine.
3. Coincide the mark on pointer provided in injection pump with the matching mark(FB) on the flange surface of the drive gear by turning the flange in the oblong holes of the drive gear.
4. Tighten the bolt(M8) to specified torque, (2.2 kgf-m) not to move the drive gear.
5. After confirmation that fastening bolts are completely tightened check the start point (injection timing degree) of fuel delivery setting once more if not right repeat it again as same as upper way.

Intake/exhaust system

General Information

The air filter purifies dust and foreign substances included in the air and supplies clean air into the engine. The air filter is directly related to engine lifetime, emissions, and engine output. Please periodically check, clean, and replace the air filter.

⚠ CAUTION

- Do not operate the engine when the air filter is separated from the engine.
- Use specified air filters only. Using unauthorized or remanufactured air filters may result in critical faults.
- Foreign substances in the engine may cause abrasion inside the engine.
- Immediately exchange a damaged air filter with a new one.
- Be careful not to let foreign substances flow into engine or damage the air filter related electric apparatus when replacing an air filter.
- Be careful not let dust inside when assembling the air filter.

Air Filter

- Air cleaner is mounted on the engine to purify the air for combustion.
- The intervals at which the air cleaner requires servicing depend on the specific operating conditions encountered.
- Clogged air filters may cause black smoke and reduce power.
- A check should be made from time to time to see that the fastening elements securing the air cleaner to the intake manifold seal the connection tightly.
- Any ingress of unfiltered air is liable to cause a high rate of cylinder and piston wear.

Disassembly of air filter

⚠ DANGER

Allowed only when the engine is stopped.

1. Empty the dust bucket periodically. The dust should not exceed the half of the dust bucket capacity.
2. You can disassemble the dust bucket by removing two clamps. Remove the dust bucket cover and empty the dust inside.
3. Assemble the cover and dust bucket accurately with care.
4. For easy alignment, the cover has dent and the dust collector has a protrusion. Here is the position where a filter is mounted horizontally, check the "TOP" mark on the air filter canister.

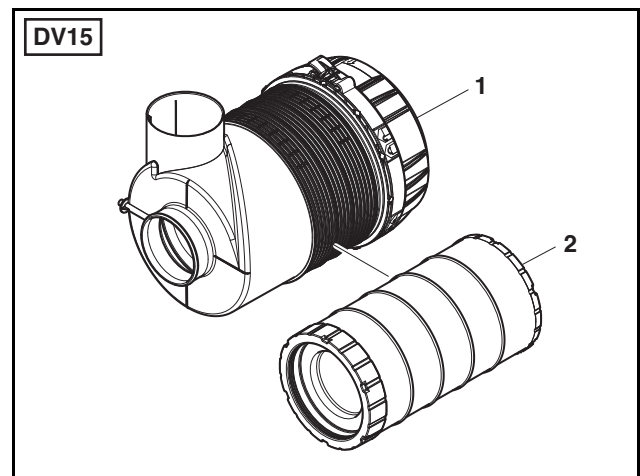

DV2213029A

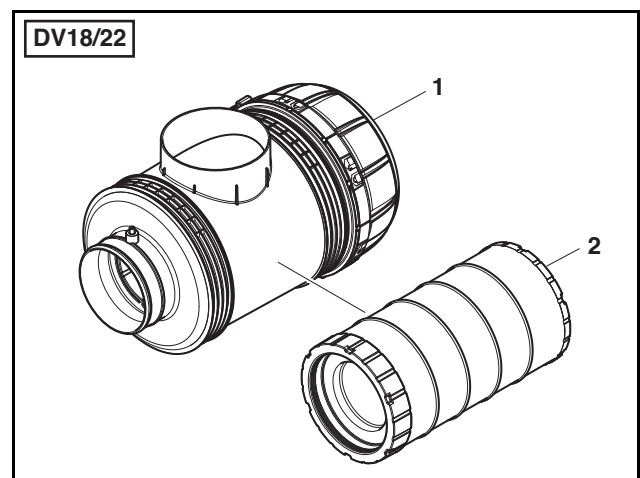

DV2213029A

1. Air cleaner ass'y
2. Air cleaner element

4. Regular inspection

Cleaning of the Air Filter Element

Clean the air filter element by using the most suitable method for your work environment among the three methods stated below.

1. Use compressed air to clean the air filter element.

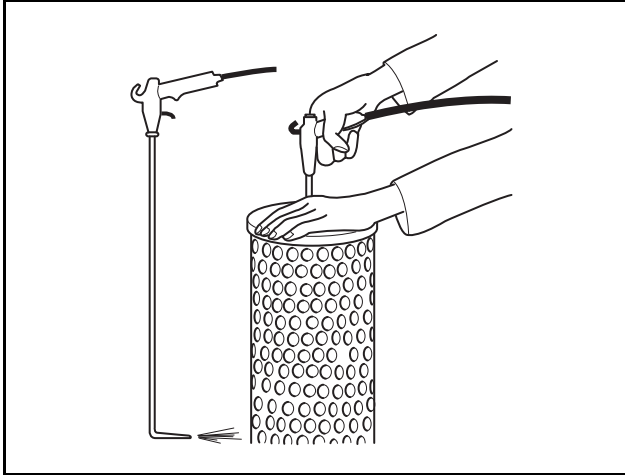

EDL022155A

- 1) To clean, let sufficient compressed air reach the inside bottom of the element at 90° direction with an air gun.
- 2) Move air gun up and down the element to blow air from inside to outside until no more dust is coming out from the element.
- 3) Do not use compressed air pressure exceeding 5 bars.

! DANGER

Always wear protective goggles before starting work. Otherwise, dust or foreign substances from the element may get in your eyes and cause injuries.

2. Clean the element by washing it.

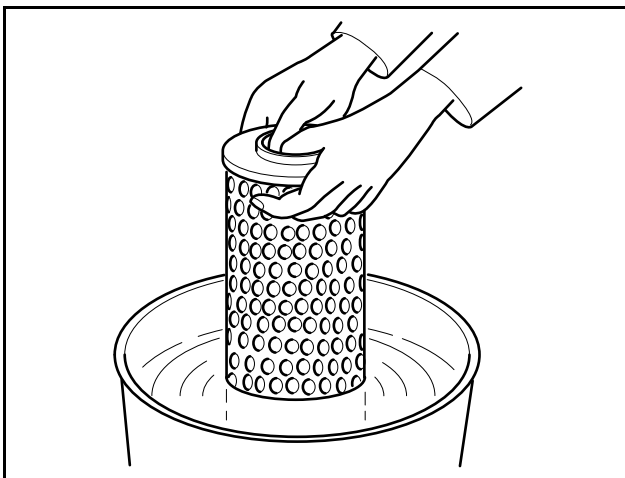

EDL022156A

- 1) Before washing the element, clean the element by using compressed air as described above.

- 2) Soak the element in the warm cleaning solvent for 10 minutes and then shake it back and forth for about 5 minutes.
- 3) Rinse the element with clean water, drain the water, and then dry it at room temperature. Fully dry the element before reassembling it to the engine.

! CAUTION

Never use steam spray, gasoline, alkali or hot cleansing solution to cleansing the element.

3. In an emergency, temporarily clean the element by using the following method.

- 1) Tap the end plate of the element with the thumb to clean it temporarily.

! CAUTION

- **This method should only be used in an emergency when cleaning of element is necessary and no compressed air or cleansing solution is available.**
- **Under no circumstances should the surface of the element be hit or beaten with a hard object to shake the dust off.**

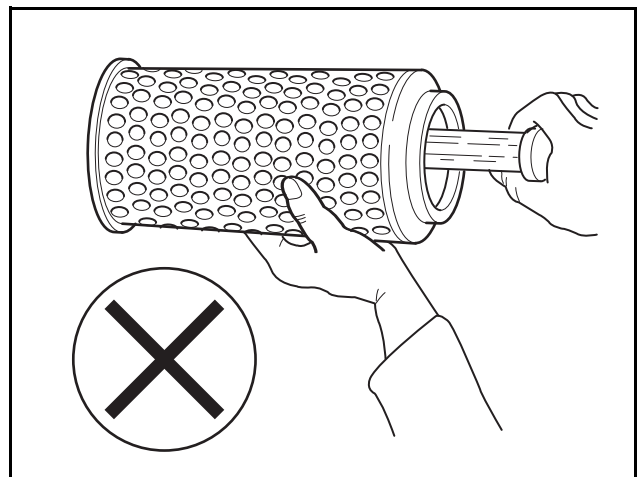

EDL022157A

Note) Before reassembling the element, make sure that the filter paper is not wrinkled, the state of rubber sealing is good, and there is no deformed part in the element.

Note) Under any circumstances, do not reuse damaged elements. When in doubt, replace the element with a new one.

4. Regular inspection

Changing the air filter element

1. Remove the hex nut, remove the dirty element.

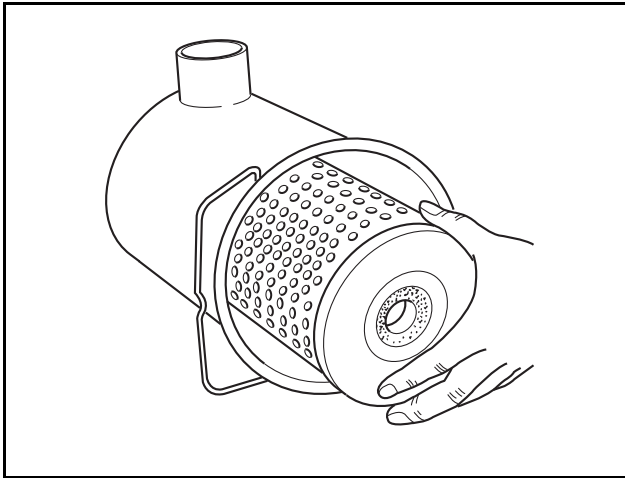

DV2213030A

2. Replace with a new one or wash it.
3. Using a wet rag, wipe the inside of the filter housing.
4. The sealing contact of element.

! DANGER

Do not let dust come into the end of air filter.

Turbocharger

The Turbocharger does not need a specific maintenance. Whenever replacing the engine oil, check oil pipe for leakage or clogging.

- You should handle the air filter with special care to prevent foreign substance from getting in.
- The turbocharged compressed air and exhaust gas pipe should be checked periodically. Air leakage causes engine overheat, so repair is required.

! CAUTION

Be careful not to bend it.

- If the impeller is severely contaminated, soak only the wheel in a solvent and clean it with a rigid brush thoroughly. Here, be sure to soak only impeller, and the turbocharger should be supported by a bearing housing, not by an impeller.

Routine check and serving the turbocharger

The turbocharger performance is determined by maintenance state of the engine. So you should regularly perform inspection and check as specified.

1. Intake system

For the intake system, the air filter should be carefully managed. For a wet type air filter, the intake resistance should be small as possible.

2. Exhaust system

For the exhaust system, when exhaust gas leaks from the exhaust pipe or turbocharger joint, supercharging efficiency is lowered. So you need to pay attention to prevent gas leakage and burn. Heat resistant nuts are used for parts which are highly heated during operation, such as the turbine seal, and the nuts should not be mixed with other nuts. The screw burn prevention paint should be applied to the assembly nuts of the specified positions.

3. Fuel system

If the spray status of the fuel injection nozzle is not good, or the injection timing is not correct, the exhaust gas temperature increases to give a negative impact on the turbocharger. So, the nozzle should be tested.

4. Lubrication system

For the lubrication system, pay attention with the oil quality and the replacement time of the cartridge of the oil filter. Degradation of engine oil has bad effect on the turbocharger, as well as the engine body.

Disassembly and cleaning a turbocharger

You can disassemble the turbocharger from the engine to clean or inspect it. Here, be sure to seal the oil inlet and outlet with a tape, etc.

4. Regular inspection

Cylinder block/head

Valve Clearance

Adjust the valve clearance.

- When disassembling the engine or cylinder head.
- When there is excessive noise in the valve connection.
- When the engine runs abnormally even if the fuel injection system is normal.

Adjusting the Valve Clearance

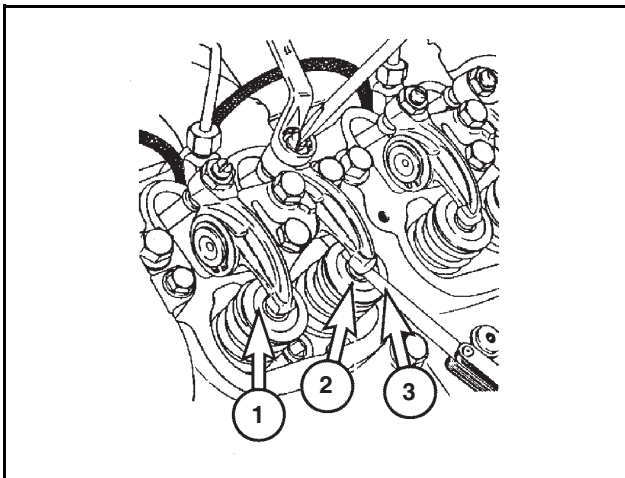

DV2213041A

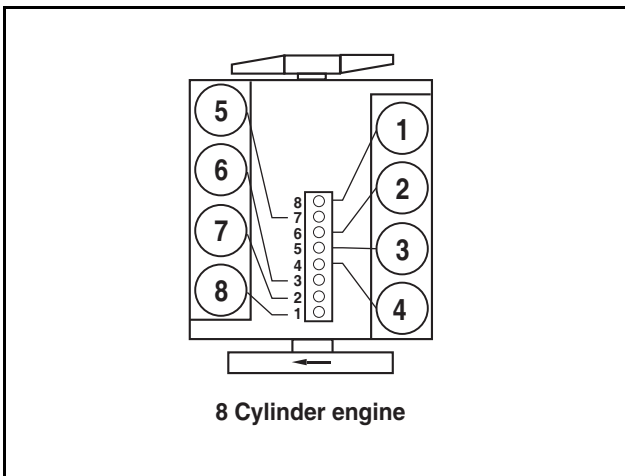

DV2213042A

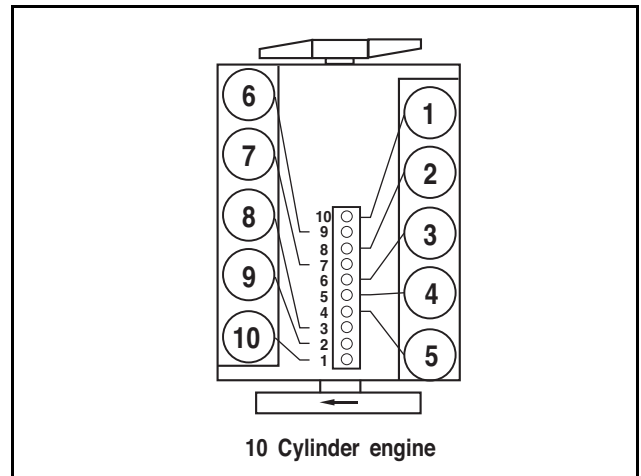

DV2213213A

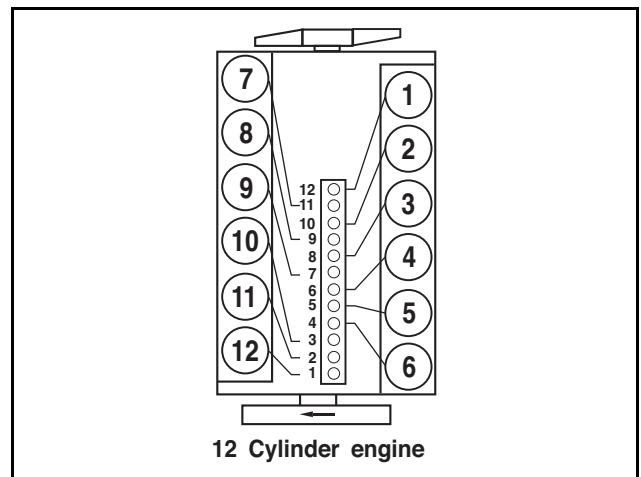

DV2213043A

1. Rotate the crankshaft so that #1. cylinder may be positioned at the compression TDC(Top Dead Center).
Note) #1. Cylinder is located at the side where cooling water pump was installed.
Note) In case of 8/12 cylinder engine, #6. cylinder is positioned at the valve overlap when #1. cylinder is positioned at the compression TDC(Top Dead Center).
Note) In case of 10 cylinder engine, #7. cylinder is positioned at the valve overlap when #1. cylinder is positioned at the compression TDC(Top Dead center).
2. Loosen the lock nut of the #1. cylinder rocker arm.
3. Push the feeler gauge between a rocker arm and a valve stem.
4. Adjust the clearance screw respectively and then tighten with the lock nut.
5. As for the valve clearance, adjust it when in cold, as follows.

4. Regular inspection

Engine Model		In. valve	Ex. valve
DP158L	DP158LCS	0.25mm	0.35mm
	DP158LCF	0.25mm	0.35mm
	DP158LDS	0.25mm	0.35mm
	DP158LDF	0.25mm	0.35mm
DP180L	DP180LBS	0.25mm	0.35mm
	DP180LBF	0.25mm	0.35mm
	DP180LAS	0.25mm	0.35mm
	DP180LAF	0.25mm	0.35mm
DP222L	DP222LAS	0.25mm	0.35mm
	DP222LBS	0.25mm	0.35mm
	DP222LBF	0.25mm	0.35mm
	DP222LCS	0.25mm	0.35mm
	DP222LCF	0.25mm	0.35mm

- Rotate the crankshaft. When a cylinder reaches the compression TDC(Top Dead Center), adjust the valve clearance of the cylinder.
- When a cylinder valve overlap, adjust the valve clearance cylinder of the compression TDC(Top Dead Center), as follow.
 - 8 cylinder engine(DP158L)

Valve overlap cylinder No.							
1	5	7	2	6	3	4	8
6	3	4	8	1	5	7	2
Adjusting valve cylinder No. (In./Ex. Valve)							

- 10 cylinder engine(DP180L)

Valve overlap cylinder No.									
1	6	5	10	2	7	3	8	4	9
7	3	8	4	9	1	6	5	10	2
Adjusting valve cylinder No. (In./Ex. Valve)									

- 12cylinder engine(DP222L)

Valve overlap cylinder No.											
1	12	5	8	3	10	6	7	2	11	4	9
6	7	2	11	4	9	1	12	5	8	3	10
Adjusting valve cylinder No. (In./Ex. Valve)											

Tightening Cylinder Head Bolt

- Retightening cylinder head bolt on new engine.

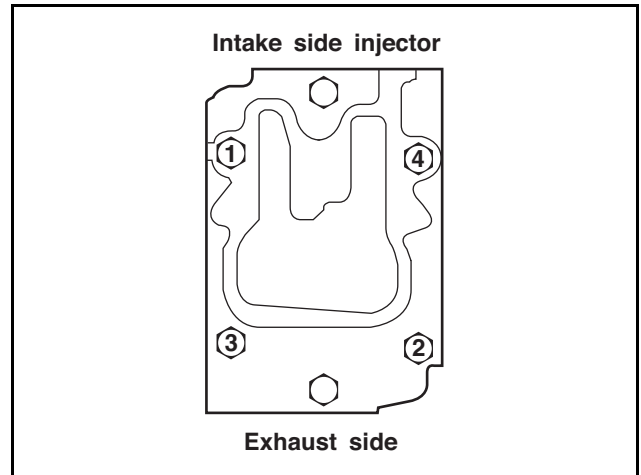

DV2213044A_E

- The cylinder heads are mounted with cylinder head bolts which are tightened by the angle-of-rotation method.
- On new engines the cylinder head bolts are tightened up for the first time at the factory after the engine has been broken in.
- After the first 400 hours of operation retighten cylinder head bolts 1 to 4 in the order shown in right figure by a further 90°(1/4 revolution).

CAUTION

- The two outer screws (intake and exhaust sides) must not be retightened.
- The cylinder head bolts to be retightened must not be loosened first, but simply tightened by a further 90°(1/4 revolution) from their actual position.

4. Regular inspection

2. Tightening cylinder head bolts after a repair. (Engine cold)

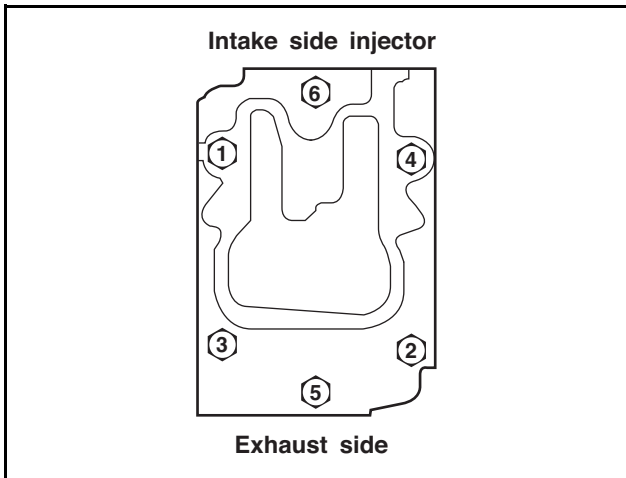

DV2213045A_E

- 1) Tighten temporarily 1~2 threads by hands.
- 2) 1st step: Tighten to about 8kgf·m with a wrench.
- 3) 2nd step: Tighten to about 15kgf·m with a wrench.
- 4) 3rd step: Rotate 90° with a wrench.
- 5) Final step: Rotate 90° with a wrench.

⚠ CAUTION

- If excessive torque may damage the cylinder head gasket, cylinder liner flange and cylinder head bolt, so keep the specified torque.
- When tightening cylinder head bolts after a repair must always adjust the valve clearance.

- 6) After the first 10 to 20 hours of operation after a repair turn the cylinder head bolts by a further 90°(1/4 revolution).

⚠ CAUTION

The cylinder head bolts to be retightened must not bolts loosened first, but simply tightened by a further 90°(1/4 revolution) from their actual position.

- 7) After 400 hours of operation turn the cylinder head bolts by a further 90°(1/4 revolution).

⚠ CAUTION

- The two outside screws (intake and exhaust side) must not be retightened.
- The cylinder head bolts to be retightened must not be loosened first, but simply tightened by a further 90°(1/4 revolution) from their actual position.
- when a cylinder head has been removed the cylinder head gasket must always be changed.

Cylinder Compression Pressure

1. Start and warm up the engine.
2. Stop the engine and disassemble the fuel injection nozzle holder assembly.
3. Install a special tool, compression pressure gauge adapter (EU.2-0532), in the fuel injection nozzle holder hole.

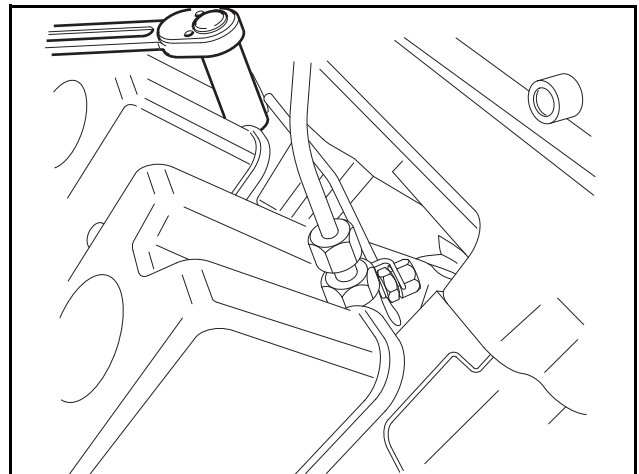

DV2213046A

4. Connect the compression pressure gauge to the adapter.

Standard	Above 28kg/cm ²
Tolerance limit	24kg/cm ²
Difference between each cylinder	Within ±10%

4. Regular inspection

Electric system

Battery

- Check for the electrolyte leakage by crack in the battery, and replace the battery if defective.
- Check the amount of electrolyte, and replenish distilled water if insufficient.
- Check the specific gravity of electrolyte. If it is below the specified value (1.12 ~ 1.28), replenish it.

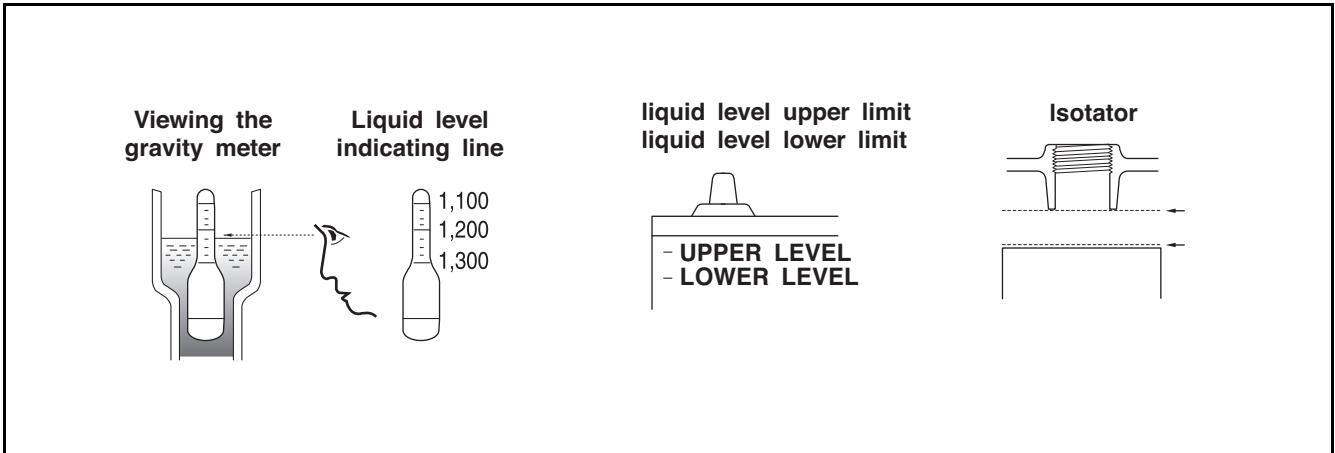

DV2213040A_E

Starter

When servicing the engine, immerse the starter motor's pinion gear and ring gear in the fuel, wash them completely, and apply grease again. When you clean the surrounding of engine, be careful so that water may not enter the starter.

CAUTION

- **Starter should be protected from humidity all the time.**
- **Before working on the electric system, be sure to disconnect the ground wire ("-" minus wire) of the battery. Short circuit may occur while working on the electrical system. Connect the ground wire last after completing all of work.**

4. Regular inspection

Others/driving system

V-Belt

The tension of the V-belts should be checked daily .

1. Change the V-belts if necessary
 - 1) If in the case of a multiple V-belt drive, wear or differing tensions are found, always replace the complete set of V-belts.
2. Checking condition
 - 1) Check V-belts for cracks, oil, overheating and wear.
3. Testing by hand

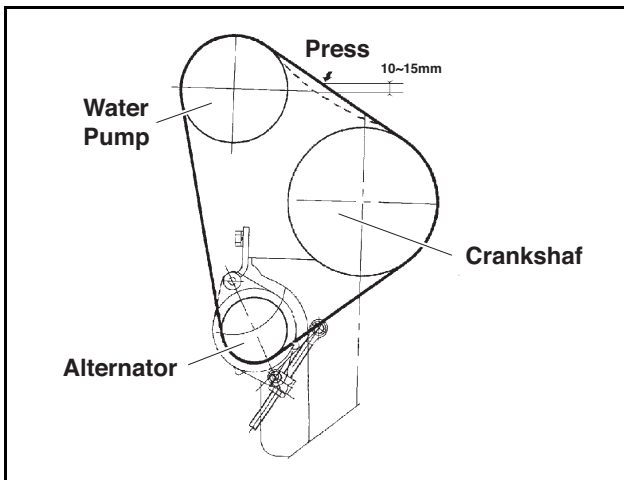

DV2213047A_E

- 1) For the V-belt tension, when you press the center between pulleys, if it is pressed by 10~15mm, it is normal.
- 2) To check the tension of V-belt more accurately, you can use a V-belt tension gauge.
4. Tension measurement
 - 1) Lower indicator arm (1) into the scale.

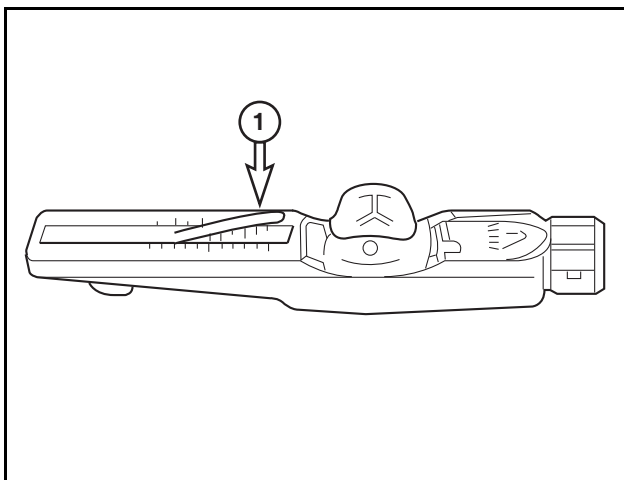

DV2213048A

- 2) Apply tester to belt at a point midway between two pulleys so that edge of contact surface (2) is flush with the V-belt.

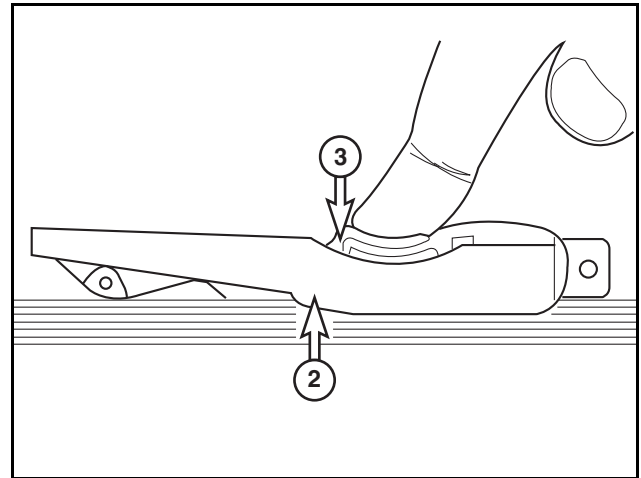

DV2213049A

- 3) Slowly depress pad (3) until the spring can be heard to disengage. This will cause the indicator (1) to move upwards.

Note) If pressure is maintained after the spring has disengaged a false reading will be obtained.

- 4) Read the tension value at the point that the top surface of indicator arm(1) intersects with the scale.
- 5) Before taking readings makes ensure that the indicator arm remains in its position.

Note) If the value measured devotes from the setting value specified, the V-belt tension must be corrected according to the following table.

Type	Belt width (mm)	Tension from a Tension Meter		
		New belt (kg)		Replacement required
		Upon installation	After 10 minute	
M	8.5	50	45	40
A	11.8	55	50	45
B	15.5	75	70	60
C	20.2	75	70	60
3V-2	18.8	90~100	70~80	60
3V-4	39.4	180~200	140~160	120
3V-6	60.0	270~300	210~240	180

5. Tension adjustment and V-belt replacement

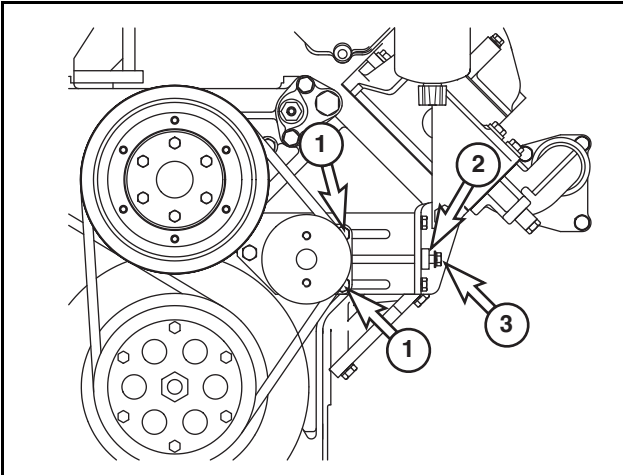

DV2213050B

- 1) Loosen the fixing bolt(1).
- 2) Loosen the lock nut(2).
- 3) Adjust the bolt(3) until belt have correct tension.
- 4) Tighten the fixing bolt(1) and nut(2).
- 5) To replace the V-belt, loosen the fixing bolts(1) and the lock nut(2) and push the tension pulley inwards by turning the adjusting bolt(3) counter clockwise.

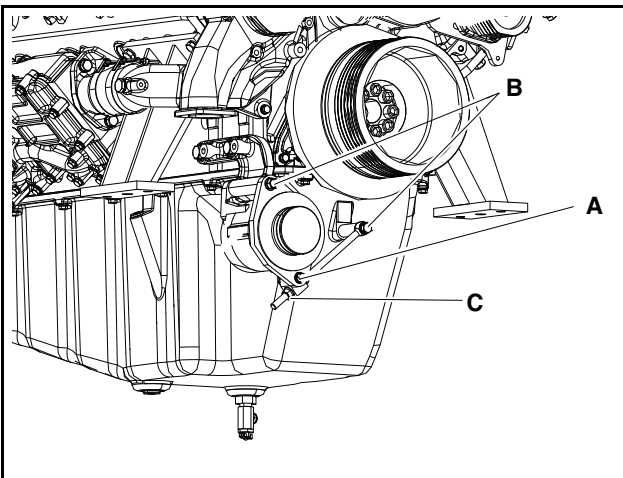

DV2213055A

- 6) Loosen the mounting bolts(B).
- 7) Loosen the lock nut(A).
- 8) Adjust the nut(C) until the belt tension has correct tensions.
- 9) Retighten the lock nut(A) and the mounting bolt(B).
- 10) To replace the belt, loosen the lock nut and push the alternator inwards.

5. About the engine

Marking system of units	73
Unit Conversion Methods	73
Tightening torque	74
Tightening Torque of Main Parts	74
Tightening Torque of General Bolts	75
Tightening torque of plug screw	77
Hollow Screw (4-Hole) Tightening Torque	77
Special tool	78
Special Tool	78
Engine Disassembly	82
Procedure of Disassembling an Engine	82
Engine Assembly	95
Procedure of Assembling Engine	95

Marking system of units

Unit Conversion Methods

The following methods show how to convert SI units to US units and vice versa.

1. To convert an SI unit to a US unit, multiply a SI unit with the number in the following table.

Note) (SI Unit) X (Number) = (US Unit)

Note) 1mm X 0.03937 = 0.03937 in

2. To convert a US unit to an SI unit, divide the US unit by the number in the following table.

Note) (US Unit) ÷ (Number) = (SI Unit)

Note) 1 in ÷ 0.03937 = 25.4 mm

Item	Number	SI Unit	US Unit
Length	0.03937	mm	in
	3.28084	m	ft
	1.093613	m	yd
	0.621371	km	mile
Area	0.00155	mm ²	in ²
	0.1550	cm ²	in ²
	10.76391	m ²	ft ²
	1.19599	m ²	yd ²
Weight	2.204623	kg	lb
	0.001	kg	t (ton)
Volume	0.061024	cc	in ³
	0.061024	ml	in ³
	0.061024	cm ³	in ³
	61.023744	L	in ³
	0.264172	L	gal
Force ^a	2.204622	kgf	lbf
	0.2248089	N	lbf
Acceleration	3.28084	m/s ²	ft/s ²
	39.37008	m/s ²	in/s ²
Torque ^b	7.233014	kgf·m	ibf·ft
	86.79619	kgf·m	ibf·in
	0.7375621	N·m	ibf·ft
	8.850748	N·m	ibf·in

Item	Number	SI Unit	US Unit
Power	1.340483	kw	Hp
Pressure	0.01	kPa	bar
	7.500615	kPa	mmHg
	20.88543	kPa	lb/ft ²
	14.2233	psi	kg/cm ²
Power	1.3596	kw	PS
	0.98635	ps	hp
Fuel Consumption	0.00162	g/kwh	lb/psh
Energy	0.000947817	J	BTU
	0.7375621	J	lbf·ft
	0.000277778	J	Wh
Luminous Flux	0.09290304	lm/m ²	lm/ft ²
Speed	0.6213712	km/h	mph
Temperature	°C	°C	°F

a. $9.806 \times (\text{kgf}) = (\text{N})$

b. $9.806 \times (\text{kgf} \cdot \text{m}) = (\text{N} \cdot \text{m})$

c. $\{(9/5) \times (^\circ\text{C}) + 32\} = (^\circ\text{F})$

$\{(^\circ\text{F}) - 32\} \times (5/9) = (^\circ\text{C})$

5. About the engine

Tightening torque

Tightening Torque of Main Parts

Main Parts	Nominal (Diameter x Pitch)	Tensile Strength Rank	Tightening Torque	Remarks
Cylinder Block Main Bearing Cap Bolt	M18 X 2	12.9T	1st: 30.0 kgf·m 2nd: 90° (Angle Method)	
Cylinder Block Bear- ing Cap Side Bolt	M12 X 1.5	10.9T	11.2kgf·m	
Flywheel Housing Bolt	M12 X 1.5	10.9T	11.2 kgf·m ±1.5 kgf·m	
	M10	12.9T	7.5 kgf·m ±1.0 kgf·m	
Flywheel Housing Cover Bolt	M8	8.8T	2.2 kgf·m ±0.3 kgf·m	
Crankshaft Pulley	M16 X 1.5	12.9T	21.0 kgf·m ±1.0 kgf·m	
Flywheel	M16 X 1.5	12.9T	1st: 10.0 kgf·m 2nd: 90° 3rd: 90° (Angle Method)	
Connecting Rod Cap	M16 X 1.5	10.9T	1st: 10.0 kgf·m 2nd: 90° (Angle Method)	
Cylinder Head	M15 X 2	12.9T	1st: 8 kgf·m 2nd: 15 kgf·m 3rd: 90° 4th: 90° 5th: 60° (Angle Method)	
Cylinder Head Cover	M8	8.8T	2.2 kgf·m ±0.33 kgf·m	
Fuel Injection Nozzle Holder	M28 X 1.5	10.9T	7.0 kgf·m ±0.5 kgf·m	
Fuel injection Pipe nut	M14 X 1.5	-	5.5 kgf·m ±0.825 kgf·m	
Rocker Arm Bracket	M10	10.9T	6.2 kgf·m	
Lock Nut (Adjusting Screw)	M12 X 1	8.8T	5 kgf·m	
Oil Pump	M8	8.8T	2.2 kgf·m	
Oil Cooler Housing	M10	10.9T	6.2 kgf·m	
Oil Cooler Cover	M8	8.8T	2.2 kgf·m	
Oil Pan	M8	8.8T	2.2 kgf·m ±0.33 kgf·m	
Oil Pan Plug	M26 X 1.5	-	8.2 kgf·m	

5. About the engine

Main Parts	Nominal (Diameter x Pitch)	Tensile Strength Rank	Tightening Torque	Remarks
Exhaust Manifold	M10	10.9T	7.0 kgf·m ±1.05 kgf·m	
Intake Manifold	M8	8.8T	2.2 kgf·m ±0.33 kgf·m	
Fuel Injection Pump (Cylinder Block)	M10 X 1.5	10.9T	5.0 kgf·m ±0.5 kgf·m	
Fuel Filter	M12 X 1.5	8.8T	7.5 kgf·m ±1.12 kgf·m	
Starter	M12 X 1.5	8T	4.4 kgf·m ±1.2 kgf·m	
Alternator Bracket	M14 X 1.5	8.8T	7.0 kgf·m ±0.5 kgf·m	
Oil Pressure Switch	PT 1/8	-	2 kgf·m	
Cooling Water Tem- perature Switch	M14 X 1.5	8.8T	2 kgf·m	

Tightening Torque of General Bolts

1. Tightening Torque of General Bolts

Please refer to the following tightening torque for the bolts which are not listed in Tightening Torque of Main Parts.

Nominal Diame- ter x Pitch (mm)	Strength Classification										
	3.6	4.6	4.8	5.6	5.8	6.6	6.8	6.9	8.8	10.9	12.9
	(4A)	(4D)	(4S)	(5D)	(5S)	(6D)	(6S)	(6G)	(8G)	(10K)	(12K)
	Elastic Limit Value (kg/mm ²)										
	20	24	32	30	40	36	46	54	64	90	106
Tightening Torque (kg·m)											
M5	0.15	0.16	0.25	0.22	0.31	0.28	0.43	0.48	0.5	0.75	0.9
M6	0.28	0.30	0.45	0.4	0.55	0.47	0.77	0.85	0.9	1.25	1.5
M7	0.43	0.46	0.7	0.63	0.83	0.78	1.2	1.3	1.4	1.95	2.35
M8	0.7	0.75	1.1	1	1.4	1.25	1.9	2.1	2.2	3.1	3.8
M8 x 1	0.73	0.8	1.2	1.1	1.5	1.34	2.1	2.3	2.4	3.35	4.1
M10	1.35	1.4	2.2	1.9	2.7	2.35	3.7	4.2	4.4	6.2	7.4
M10 x 1	1.5	1.6	2.5	2.1	3.1	2.8	4.3	4.9	5	7	8.4
M12	2.4	2.5	3.7	3.3	4.7	4.2	6.3	7.2	7.5	10.5	12.5
M12 x 1.5	2.55	2.7	4	3.5	5	4.6	6.8	7.7	8	11.2	13.4
M14	3.7	3.9	6	5.2	7.5	7	10	11.5	12	17	20
M14 x 1.5	4.1	4.3	6.6	5.7	8.3	7.5	11.1	12.5	13	18.5	22
M16	5.6	6	9	8	11.5	10.5	17.9	18.5	18	26	31

5. About the engine

Nominal Diameter x Pitch (mm)	Strength Classification										
	3.6	4.6	4.8	5.6	5.8	6.6	6.8	6.9	8.8	10.9	12.9
	(4A)	(4D)	(4S)	(5D)	(5S)	(6D)	(6S)	(6G)	(8G)	(10K)	(12K)
	Elastic Limit Value (kg/mm ²)										
	20	24	32	30	40	36	46	54	64	90	106
Tightening Torque (kg·m)											
M16 x 1.5	6.2	6.5	9.7	8.6	12.5	11.3	17	19.5	20	28	33
M18	7.8	8.3	12.5	11	16	14.5	21	24.2	25	36	43
M18 x 1.5	9.1	9.5	14.5	12.5	18.5	16.7	24.5	27.5	28	41	49
M20	11.5	12	18	16	22	19	31.5	35	36	51	60
M20 x 1.5	12.8	13.5	20.5	18	25	22.5	35	39.5	41	58	68
M22	15.5	16	24.5	21	30	26	42	46	49	67	75
M22 x 1.5	17	18.5	28	24	34	29	47	52	56	75	85
M24	20.5	21.5	33	27	40	34	55	58	63	82	92
M24 x 1.5	23	25	37	31	45	38	61	67	74	93	103

Note) The standard torque values above are about 70% of the bolt elastic limit values.

Note) The tensile force has been calculated by multiplying the tensile strength with the screw cross-sectional area.

Note) A special screw should be tightened with 85% of the tightening torque of the standard value. For example, a MoS₂-coated screw should be tightened with 60% of the tightening torque of the standard value.

2. Tightening Torque of Key General Bolts

Nominal Diameter x Pitch (mm)	Strength Classification			Remarks
	8.8T	10.9T	12.9T	
	Tightening Torque (kgf·m) ± 10%			
M6 x 1	1	1.25	1.5	
M8 x 1.25	2.2	3.1	3.8	
M8 x 1	2.4	3.35	4.1	
M10 x 1.5	4.4	6.2	7.4	
M10 x 1.0	5	7	8.4	
M12 x 1.75	7.5	10.5	12.5	
M12 x 1.5	8	11.2	13.4	
M14 x 1.5	13	18.5	22	

5. About the engine

Tightening torque of plug screw

M10	M12	M14	M16	M18	M22	M24	M26	M30
5.0	5.0	8.0	8.0	10.0	10.0	12.0	12.0	15.0

Hollow Screw (4-Hole) Tightening Torque



Material Classification	M8	M10	M12	M14	M16	M18	M22	M26	M30	M38
SM25C	-	1.6	2.5	3.5	4.5	5.5	9.0	13.0	18.0	30.0
SUM22L ^a	0.8	1.8	3.0	4.0	5.5	6.5	11.0	16.0	20.0	35.0
STS304	0.8	1.8	3.0	4.0	5.5	6.5	11.0	16.0	20.0	35.0

a. Applied to Doosan Engines

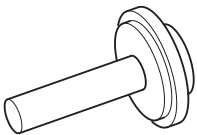
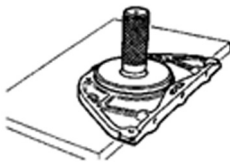
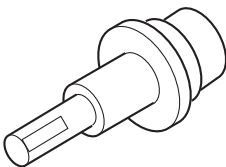
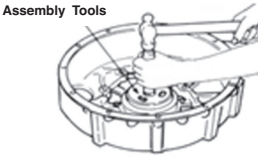

5. About the engine

Special tool

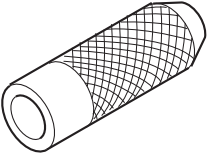
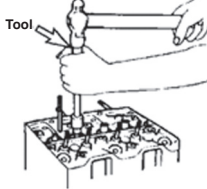
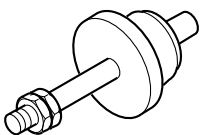
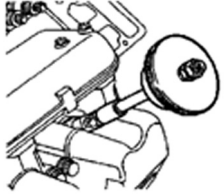



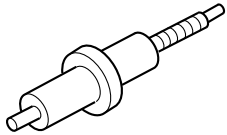
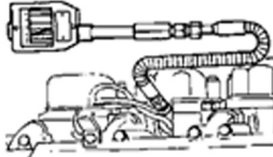

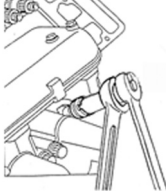
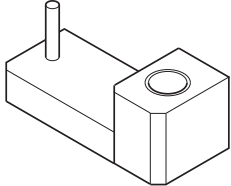
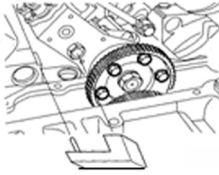
Special Tool

No.	Product Number	Shape	Application	Work Tips
1	EF.120-030 Front Oil Seal Assembly Jig			First, place the tool onto the cylinder block, and insert "T" shape plate of the tool into the cylinder liner and hook it on the bottom of the cylinder liner. Pull out the cylinder liner by turning the hexagonal nut of the tool.
2	EF.120-029 Rear Oil Seal Assembly Jig			First, lubricate sealing lip of oil seal with engine oil and join radial seal to the tool, then fit it into the hole of the flywheel housing. Second, install the oil seal by tapping the rear face of the tool with hammer slightly.
3	EF.120-262 Valve Spring Press			First, assemble the tool on the cylinder head properly with a stud bolt and a nut. Second compress the valve spring by pressing down the tool handle, then detach the cotter pins and springs.
4	EF.120-183 Valve Stem Seal Punch			First, join the valve stem seal to the valve stem. Second, place the tool onto the valve stem seal, then install the valve stem seal by tapping the end face of the tool shank with a plastic hammer slightly until it is assembled to the valve guide firmly.
5	EI.00308-0084 Inertia Extractor			First unscrew the nut of nozzle holder, then install the tool at the end of nozzle holder, and tighten it. Second pull out the nozzle holder by slugging the rear end of the tool with assembled weight disc.

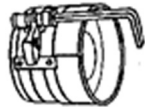

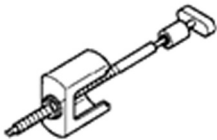

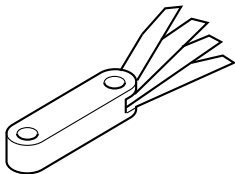
5. About the engine

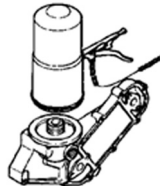
No.	Product Number	Shape	Application	Work Tips
6	EU.2-0532 Adapter for Cylinder Pressure Test			<p>First, detach the injection nozzle from cylinder head and assemble the tool into the nozzle hole. Attach the extension at the nozzle end, then join the compression pressure gauge to the extension end.</p> <p>Second, test compression pressure by cranking engine (at starter speed only) on condition that injection pump is not running. Repeat the test until the maximum compression pressure is acquired.</p>
7	60.99901-0036 Jig for injection Nozzle Detach			<p>First, link the tool to the nozzle with projection of the tool then connect it by tightening the upper bolt of the tool with a spanner.</p> <p>Second, detach the nozzle by turning the lower large nut of the tool counter clockwise.</p>
8	EF.120-189 Injection Pump Alignment Jig			<p>First, fix the jig's hole on the limit cap of the injection pump.</p> <p>Second, rotate the jig counterclockwise and align the pin of the jig to the machined corner of the cylinder block, then assemble the injection pump.</p>

5. About the engine

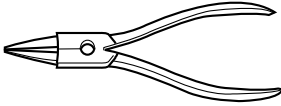
No.	Product Number	Shape	Application	Work Tips
9	EF.120-208 Piston Ring Compressor			<p>First, assemble the connecting rod and piston rings to the piston.</p> <p>Then, insert the connecting rod of the piston assembly into the tool from tapered part of the tool, and push the piston until the piston is still in the tool.</p> <p>Place the tool with the piston assembly onto the liner hole.</p> <p>(Before this, insert the connecting rod of the piston assembly into the liner hole.)</p> <p>Assemble the piston assembly by pushing the upper part of piston into the cylinder liner through the tool until it is passed the tool completely.</p>
10	EF.123-365 Cylinder Liner Puller			<p>First, place the tool onto the cylinder block, and insert "T" shape plate of the tool into the cylinder liner and hook it on the bottom of the cylinder liner.</p> <p>Pull out the cylinder liner by turning the hexagonal nut of the tool.</p>
11	60.99901-0027 Feeler Gauge			<p>Determine the gaps of the valves or back lash of the gear, etc.</p>
12	EF.200-038 Chain Plier			<p>First, wind the chain of tool around oil filter cartridge and adjust the length of chain adequately by turning adjustable screw of the tool.</p> <p>Second, grip the lever of the tool and detach the cartridge by rotating the tool counterclockwise.</p>

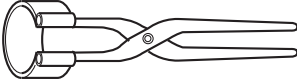
5. About the engine

No.	Product Number	Shape	Application	Work Tips
13	T7610001E Snap Ring Plier			<p>Put two sharp points of the tool into the holes of snap ring at the same time and grip the both lever of the tool a little, then remove the snap ring from the position pin.</p>
14	T7621010E Pis- ton Ring Plier			<p>When disassemble or assemble the piston rings from piston use the piston ring plier in order not to be scratched the piston surface by ring's keen edge. After expanding the both ends of piston ring as figure using special tool, remove the piston rings.</p>

5. About the engine

Engine Disassembly

Procedure of Disassembling an Engine

CAUTION

- Prepare tools and genuine parts necessary before disassembling engine.
- Prepare a shelf for the storage of removed parts.
- Perform repairs in a light and clean space.
- Keep hands clean while performing repairs.
- Keep parts removed from the engine in the order of disassembly.
- Do not allow parts removed from the engine to touch each other or be mixed with other parts.

Disassemble the engine in the following order.

1. Remove the cooling fan.

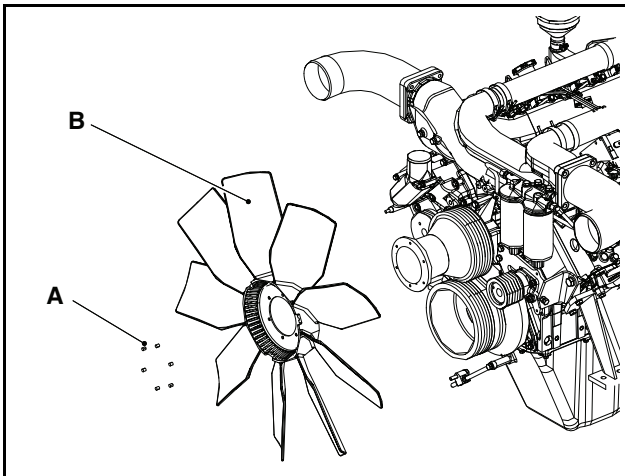

DV2213052A

- 1) Loosen 6 fixing bolts(A).
- 2) Remove the cooling fan(B).

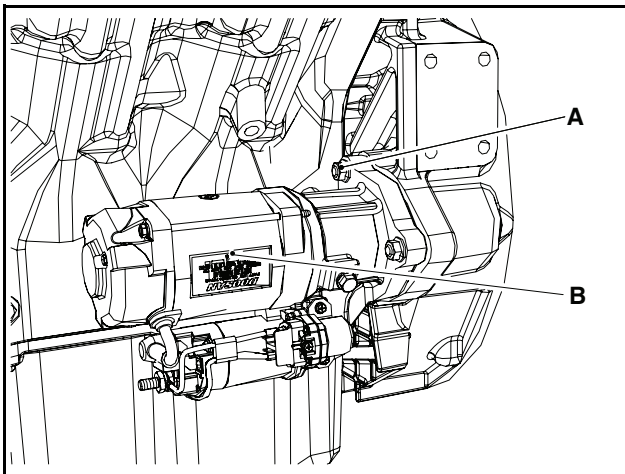

DV2213053A

- 1) Loosen 3 fixing nuts(A).

- 2) Remove the starter(B).
3. Discharge cooling water.
"Discharging the coolant" on page 48
4. Drain engine oil.

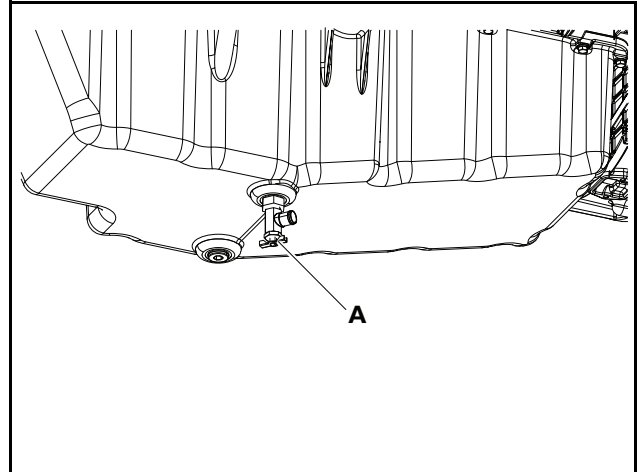

DV2213168A

- 1) Loosen the drain valve(A) of the oil pan and then drain engine oil.
5. Remove the V-belt.

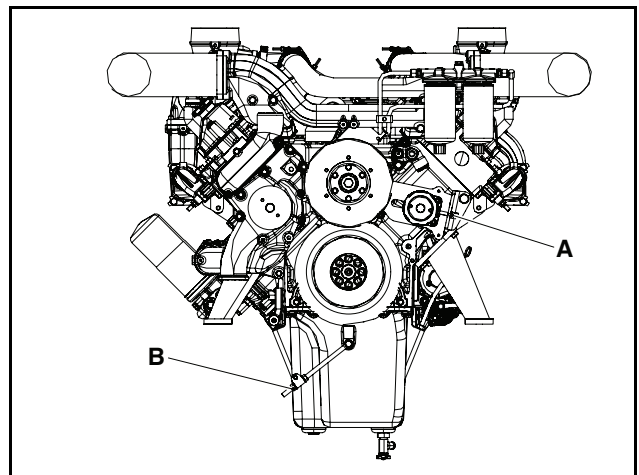

DV2213054A

- 1) Turn the adjusting nut(A) and then remove the V-belt.
- 2) Turn the adjusting nut(B) and then remove the V-belt.

5. About the engine

6. Remove the alternator.

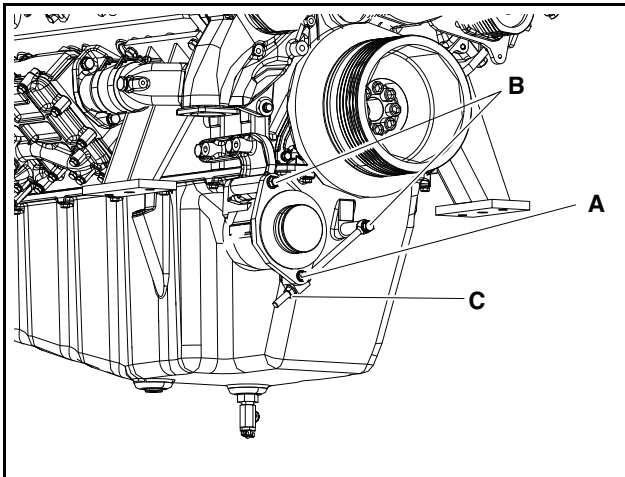

DV2213055A

- 1) Loosen the fixing nut(A) and bolt(B).
- 2) Remove the alternator(C).

7. Remove the alternator bracket.

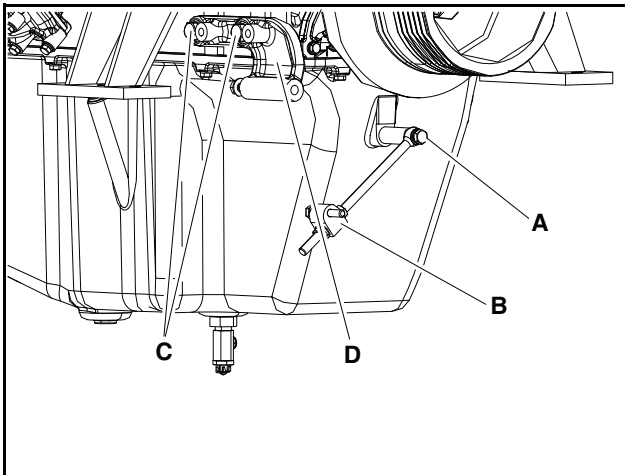

DV2213056A

- 1) Loosen the fixing bolt(A) and then remove the eyebolt(B).
- 2) Loosen the fixing bolt(C) and then remove the alternator bracket(C).

8. Remove the inlet elbow.

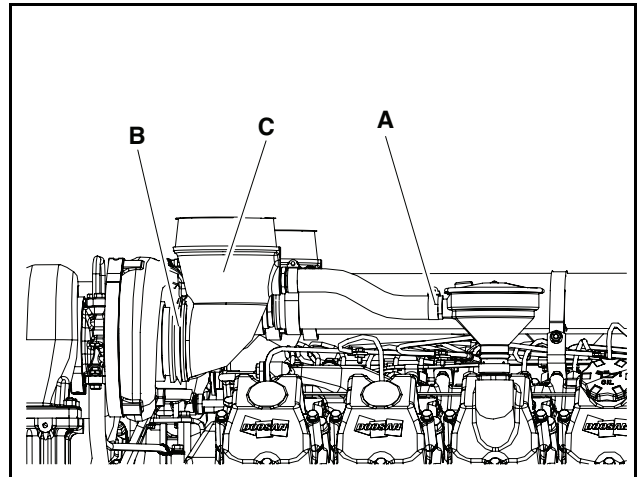

DV2213057A

- 1) Loosen the hose clamp(A).
- 2) Loosen the V-clamp(B).
- 3) Remove the inlet elbow(C).
- 4) Remove the other side elbow as the same procedure.

⚠ CAUTION

Be careful not to loss the O-ring and insert parts when removing the inlet elbow.

9. Remove the oil delivery pipe.

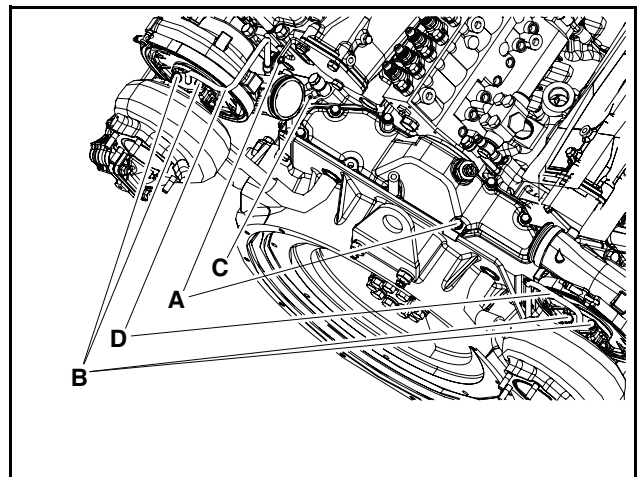

DV2213058A

- 1) Loosen the the fixing bracket bolts(A) of the oil delivery pipe.
- 2) Loosen the fixing bolts(B) of the oil delivery pipe.
- 3) Loosen the hollow screw(C).
- 4) Remove the oil delivery pipe(D).

⚠ CAUTION

Be careful not to loss the O-ring and the gasket.

5. About the engine

10. Remove the oil return pipe.

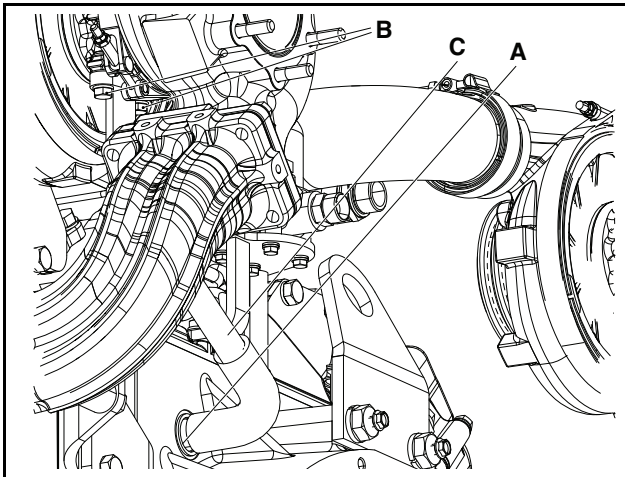

DV2213169A

- 1) Loosen the clamp(A).
 - 2) Loosen 2 fixing bolts(B)
11. Remove the turbocharger.

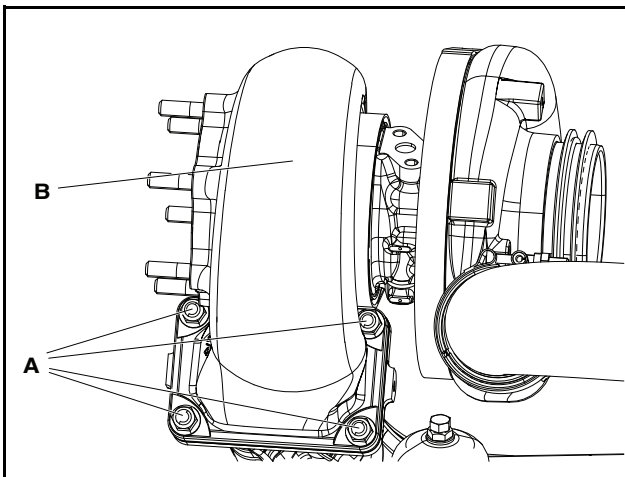

DV2213170A

- 1) Loosen 4 fixing nuts(A).
- 2) Remove the turbocharger(B).
- 3) Remove the other side turbocharger as the same procedure.

12. Remove the exhaust manifold and elbow assembly.

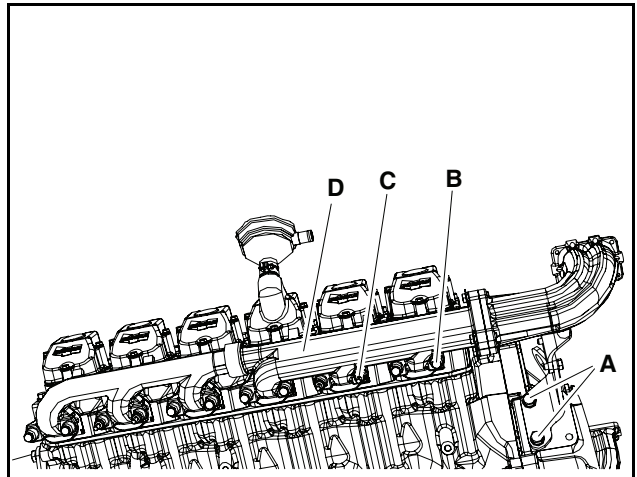

DV2213060A

- 1) Remove the heat screen.
- 2) Loosen the fixing bolts(A) of the exhaust elbow bracket.
- 3) Loosen 8 fixing bolts(B) and 4 fixing bolts(C).
- 4) Remove the exhaust manifold and elbow assembly(D).
- 5) Remove the other side exhaust manifold and elbow assembly as the same procedure.

CAUTION

Be careful not to mix the fixing bolts each other.

13. Remove the intake stake.

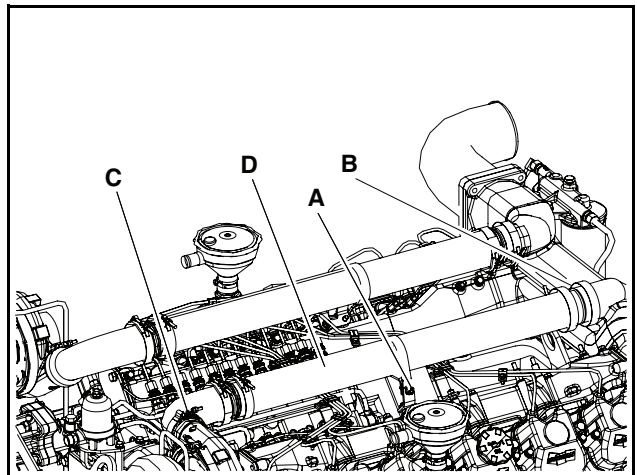

DV2213061A

- 1) Loosen the fixing bolt(A).
- 2) Loosen the hose clamp(B).
- 3) Loosen the V-clamp(C).
- 4) Remove the intake stake(D).

5. About the engine

- 5) Remove the other side intake stake as the same procedure.

⚠ CAUTION

Be careful not to let dust inside the engine.

14. Remove the fuel filter.

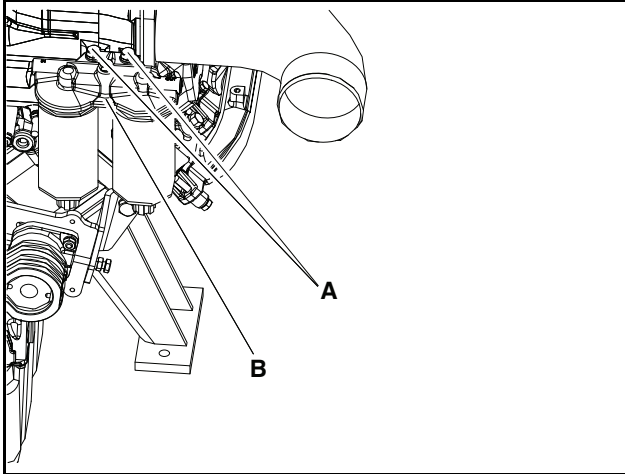

- 1) Loosen the fixing bolts(A).
- 2) Remove the fuel filter assembly(B).

15. Remove the inlet pipe.

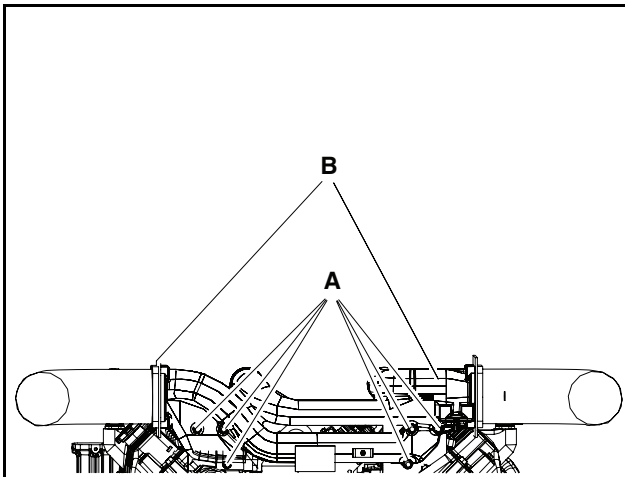

- 1) Loosen the fixing bolts(A).
- 2) Remove the inlet pipe(B).

16. Remove the fuel injection pipe assembly.

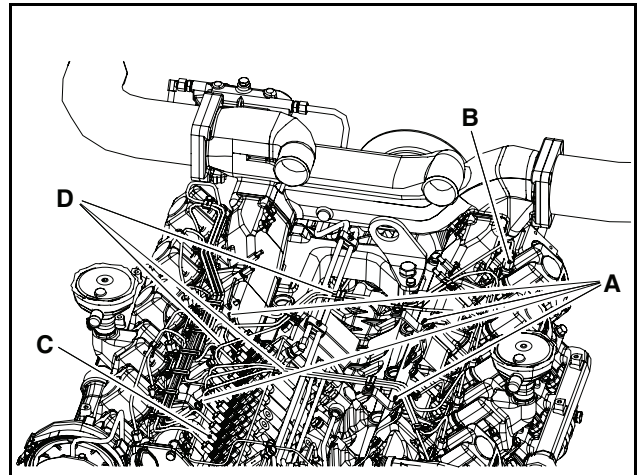

- 1) Loosen the fixing bolts(A).
- 2) Loosen 12 fuel injection pipe nuts(B) connected the injector.
- 3) Loosen 12 fuel injection pipe nuts(C) connected the fuel injection pump.
- 4) Remove 3 fuel injection pipe assemblies.

⚠ CAUTION

- **Be careful not to damage the fuel injection pipes.**
- **Be careful not to let dust inside the fuel injection pipes.**
- **Be careful not to let dust inside the fuel injection pipes.**

17. Remove the fuel pipe.

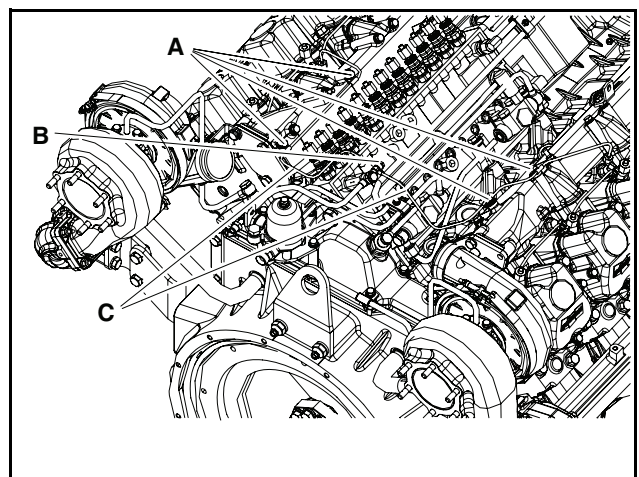

- 1) Loosen the fixing bolts(A).
- 2) Loosen the hollow screw(B).

5. About the engine

3) Remove the fuel pipes(C).

CAUTION

- Be careful not to lose the O-ring.
- Be careful not to damage the fuel pipes.

18. Remove the fuel pipe.

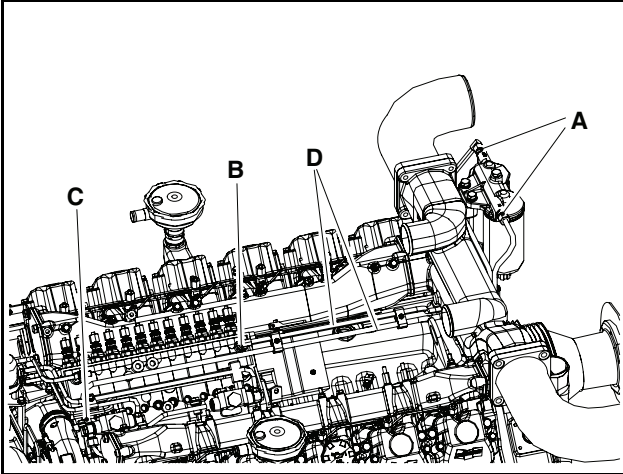

DV2213068A

- 1) Loosen the fixing nuts(A).
- 2) Loosen the fixing nuts(B) and (C).
- 3) Remove the fuel pipe(C)

CAUTION

Be careful not to damage the fuel pipes.

19. Remove the fuel and oil hoses.

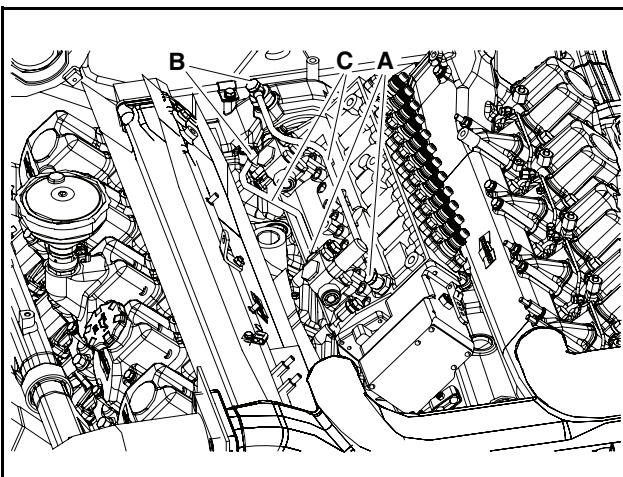

DV2213070A

- 1) Loosen the fixing bolts(A).
- 2) Loosen the hollow screws(B).
- 3) Remove the fuel and oil hoses(C).

20. Remove the oil filter assembly.

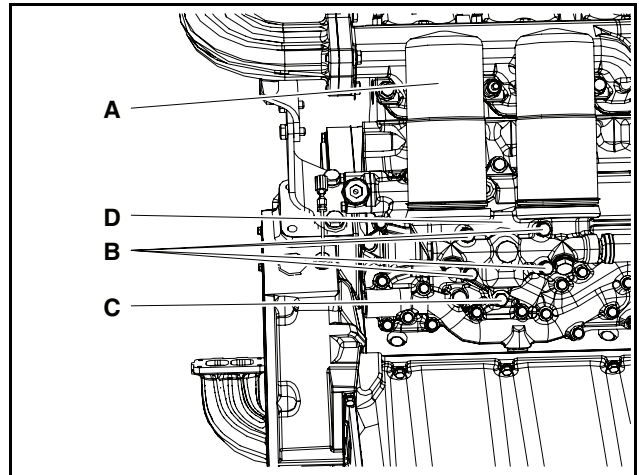

DV2213082A

- 1) Remove the oil filter with the chain plier(EF.200-038).
- 2) Loosen the fixing bolt(B) and (C).
- 3) Remove the oil filter housing.

CAUTION

- Be careful not to lose the gasket.
- Be careful not to run down oil.

21. Remove the fuel pre-filter.

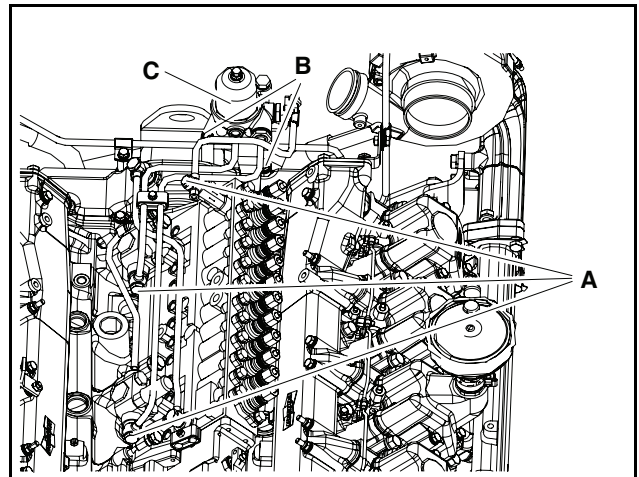

DV2213065A

- 1) Loosen the hollow screws(A).
- 2) Loosen the fixing bolts(B).
- 3) Remove the fuel return pipe and fuel pre-filter.

CAUTION

Be careful not to damage the fuel injection pipes.

5. About the engine

22. Remove the intake manifold.

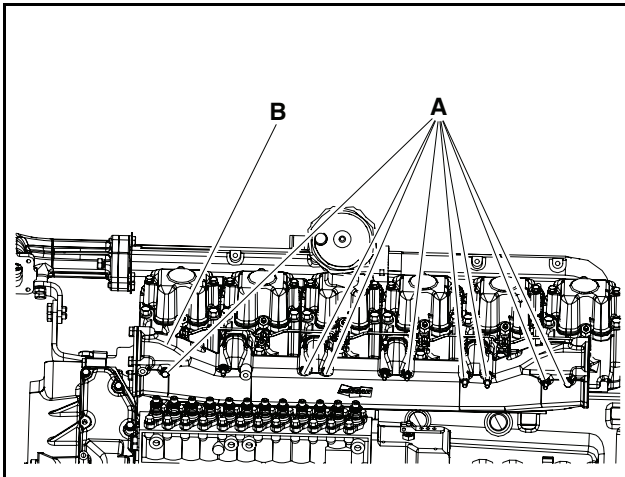

DV2213066A

- 1) Loosen the fixing bolts(A).
- 2) Remove the intake manifold(B).
- 3) Remove the other side intake manifold as the same procedure.

CAUTION

Be careful not to mix the fixing bolts each other.

23. Remove the cylinder head cover.

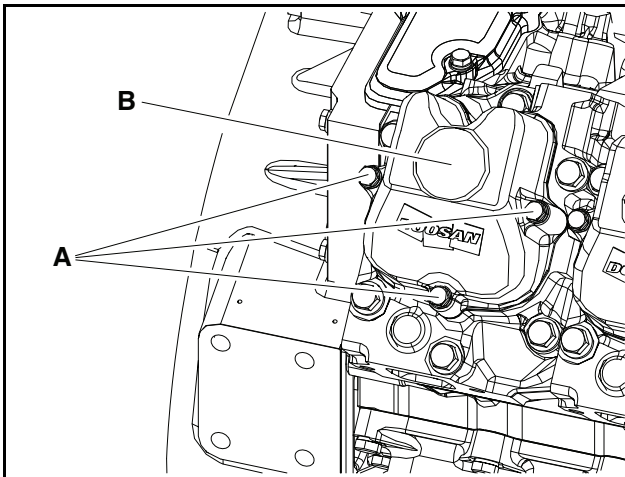

DV2213074A

- 1) Loosen 3 fixing bolts(A).
- 2) Remove the cylinder head cover(B) and the gasket.
- 3) Remove the other side cylinder head cover and gasket as the same procedure.

24. Remove the fuel return pipe.

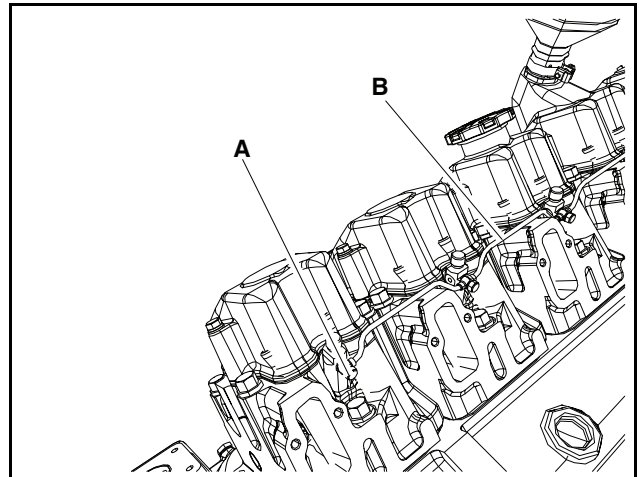

DV2213069A

- 1) Remove the hollow screw and 6 seal rings(A).
 - 2) Remove the fuel return pipe(B).
 - 3) Remove the other side fuel return pipe as the same procedure.
25. Remove the injectors.

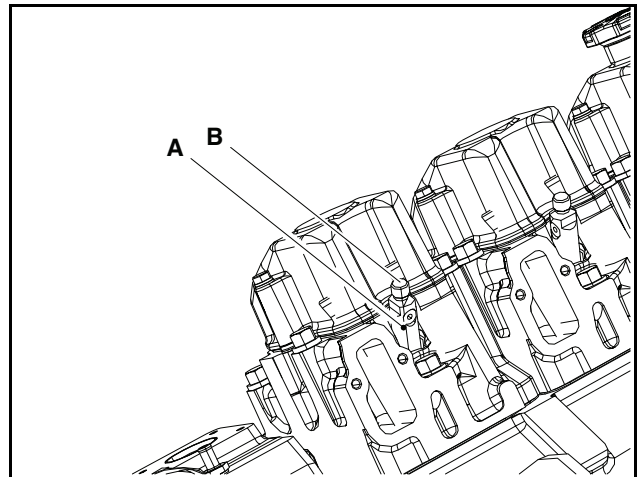

DV2213073A

- 1) Remove the injector holder fixing nut(B) with the jig for injection nozzle detach(60.99901-0036).
- 2) Remove the injector(A).
- 3) Remove 12 injectors as the same procedure.

CAUTION

Be careful not to damage the fuel pipes.

5. About the engine

26. Remove the flywheel housing cover.

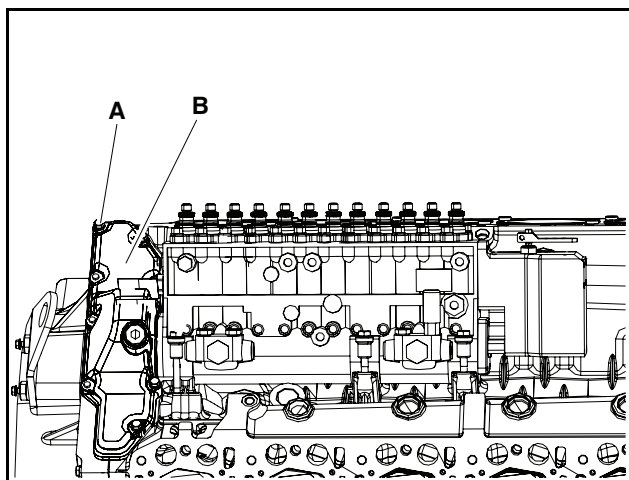

DV2213071A

- 1) Loosen the fixing bolts(A).
 - 2) Remove the flywheel housing cover(B).
27. Align the fuel injection pump pointer.

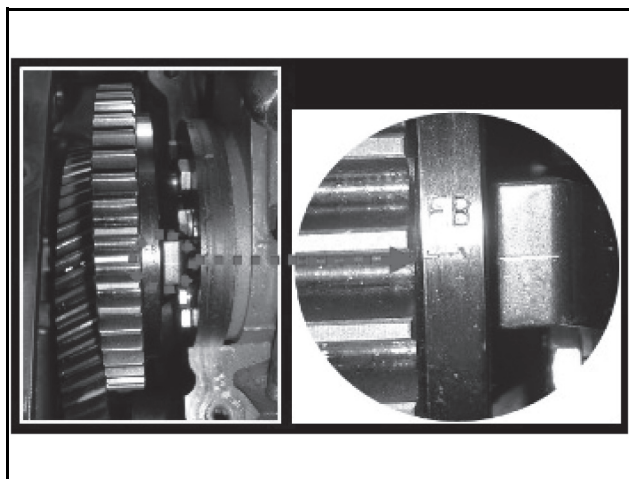

DV2213171A

- 1) Rotate the flywheel to the engine rotation direction.
- 2) The injection timing pointer marking on the fuel injection pump driven gear is aligned with marking on the cylindrical surface.

28. Remove the fuel injection pump.

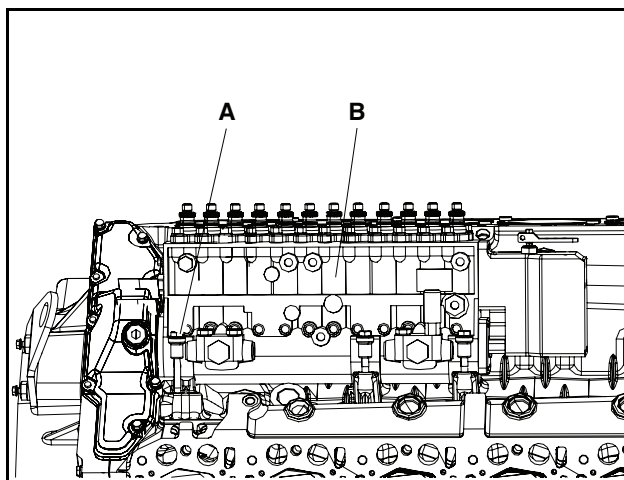

DV2213072A

- 1) Loosen 6 fixing bolts(A).
 - 2) Remove the fuel injection pump(B).
29. Remove the rocker arm assembly.

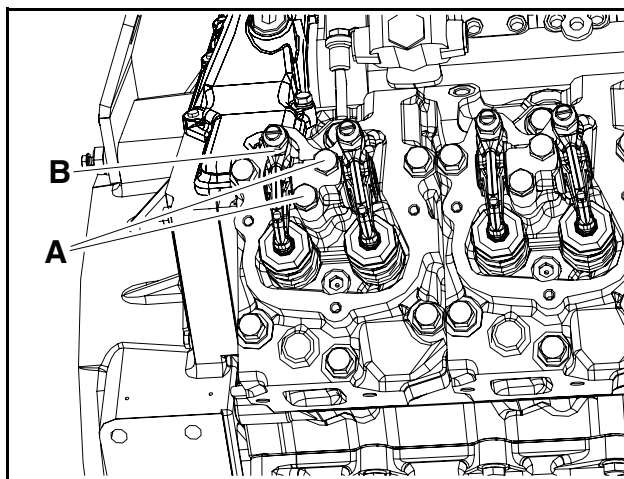

DV2213075A

- 1) Loosen the fixing bolts(A).
- 2) Remove the rocker arm assembly(B).
- 3) Remove 12 rocker arm assemblies as the same procedure.

5. About the engine

30. Remove the push rods.

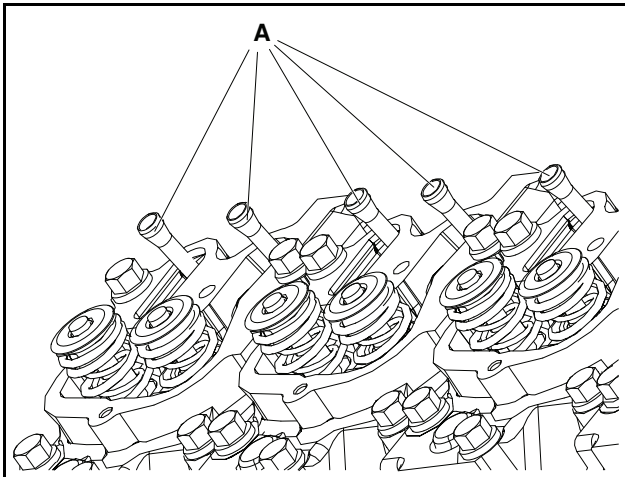

DV2213076A

1) Remove 24 push rods(A).

31. Remove the cylinder head assembly.

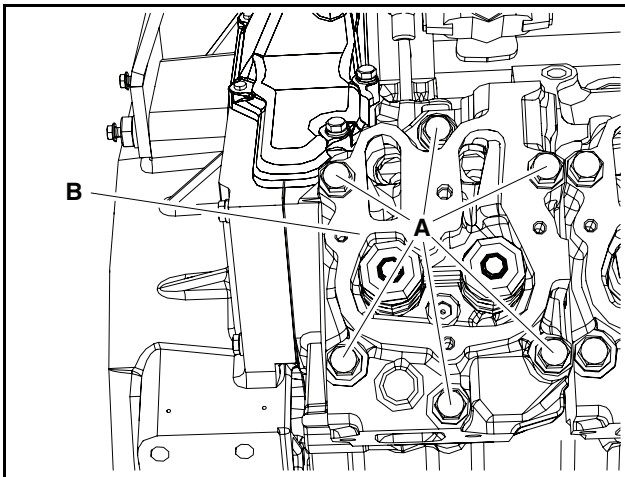

DV2213077A

1) Loosen 6 fixing bolts(A).

2) Remove the cylinder head assembly(B).

3) Remove 12 cylinder head assemblies as the same procedure.

32. Remove the cooling water pipe.

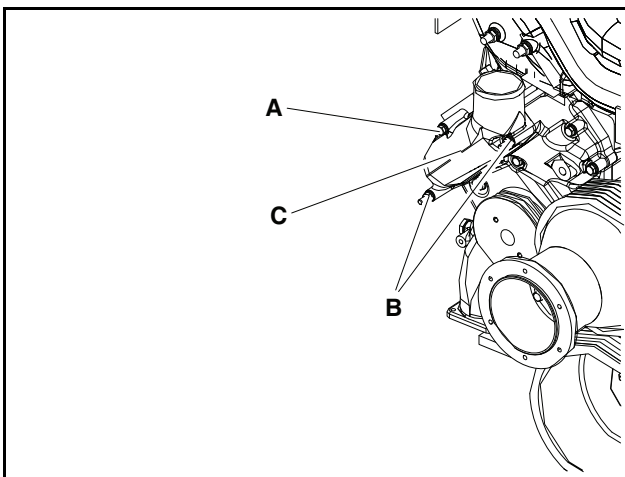

DV2213078A

1) Loosen the fixing bolts(A) and nuts(B).

2) Remove the cooling water pipe(C).

33. Remove the thermostat.

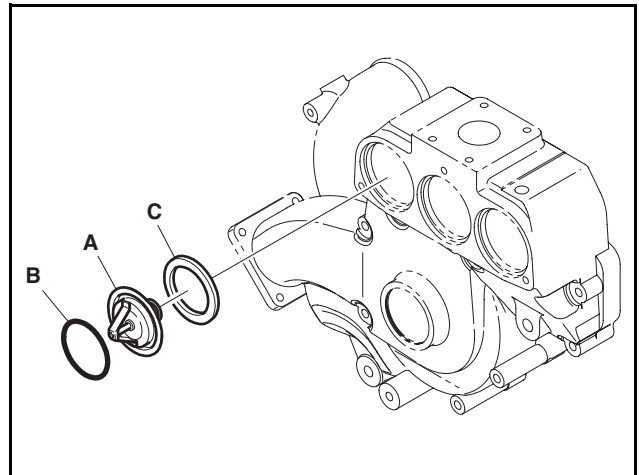

DV2213172A

1) Remove the O-ring(B).

2) Remove the thermostat(A).

3) Remove the gasket(C).

4) Remove 3 thermostats as the same procedure.

34. Remove the water pump assembly.

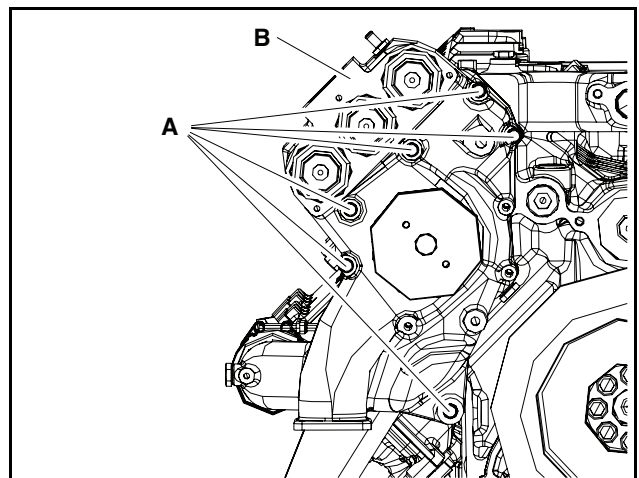

DV2213173A

1) Loosen 6 fixing bolts(A).

2) Remove the water pump assembly(B).

CAUTION

Be careful not to mix the fixing bolts each other.

5. About the engine

35. Remove the idle pulley and cooling fan pulley assembly.

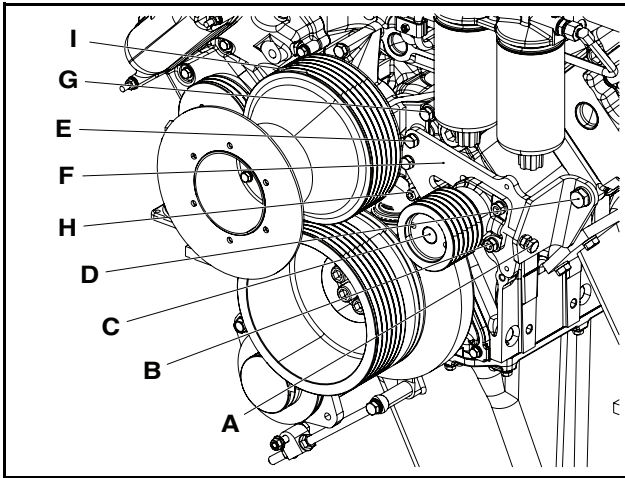

DV2213174A

- 1) Loosen 1 fixing bolt(A) and 2 fixing nuts(B).
 - 2) Remove the idle pulley(C).
 - 3) Loosen 1 fixing bolt(D) and 2 fixing bolts(E).
 - 4) Remove the idle pulley bracket(F).
 - 5) Loosen 3 fixing bolts and 1 socket bolt.
 - 6) Remove the cooling fan assembly(I).
36. Remove the crankshaft pulley.

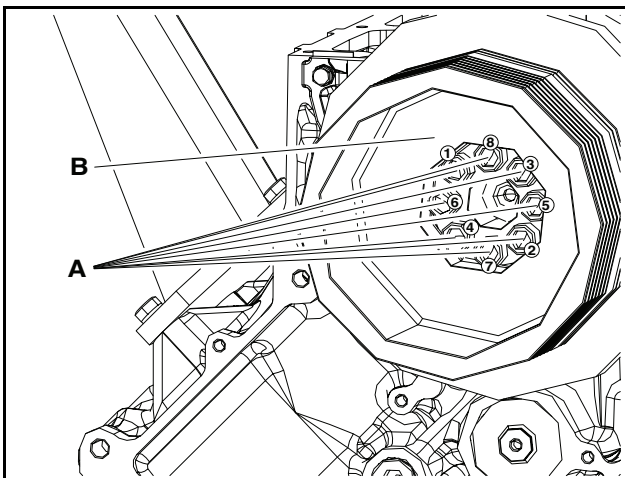

DV2213175A

- 1) Loosen 8 fixing bolts(A) in the order of 1 ~ 8.
- 2) Remove the crankshaft pulley(B).

37. Remove the oil cooler cover.

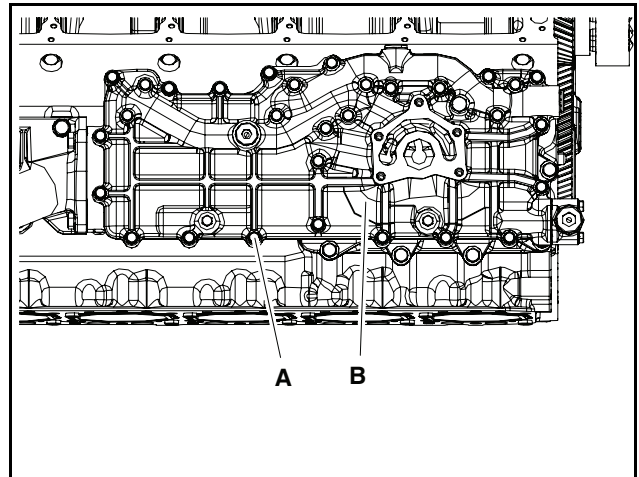

DV2213083A

- 1) Loosen 20 fixing bolts(A).
- 2) Remove the oil cooler cover(B).

⚠ CAUTION

Remove the gasket on the assembly surface.

38. Remove the cooling water pipe.

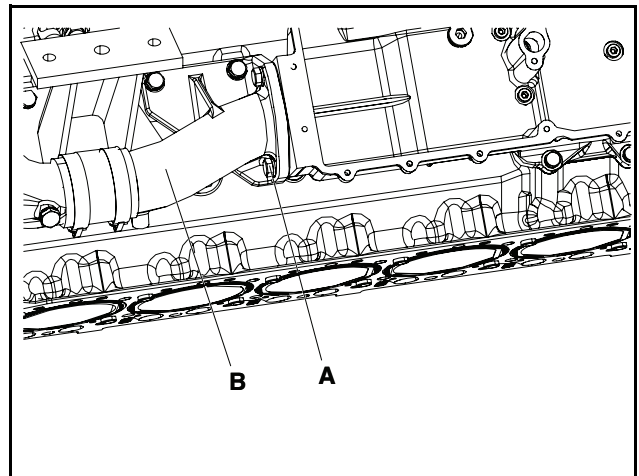

DV2213084A

- 1) Loosen fixing bolts(A).
- 2) Remove the cooling water pipe(B).

5. About the engine

39. Remove the oil cooler housing.

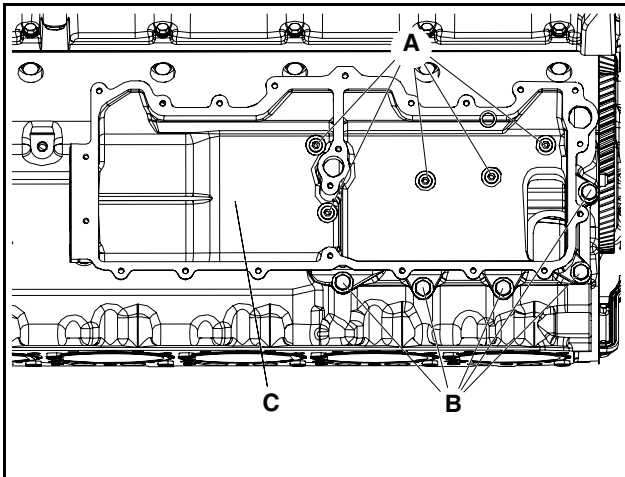

DV2213085A

- 1) Loosen 5 inner socket bolts(A).
 - 2) Loosen 5 outer fixing bolts(B).
 - 3) Remove the oil cooler housing(C).
40. Change the engine position.

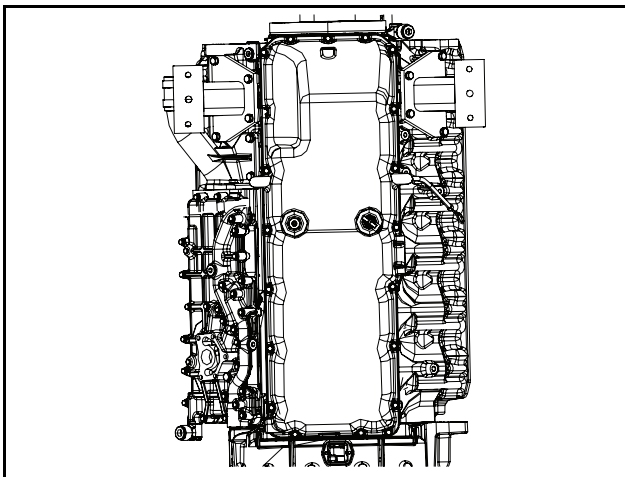

DV2213176A

- 1) Change the engine position. The flywheel housing direction is downward.
41. Remove the oil pan.

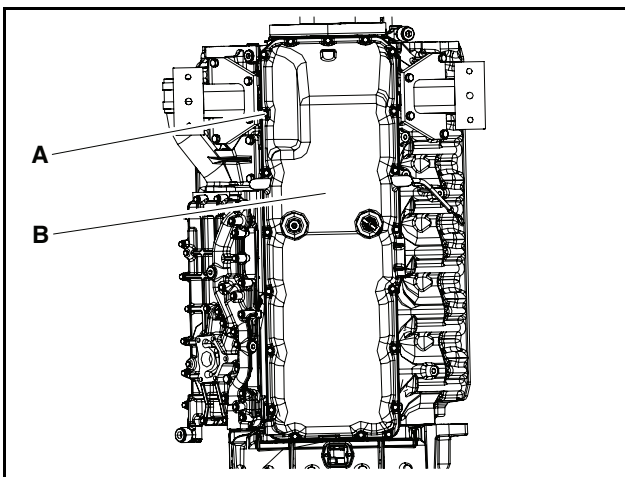

DV2213086A

- 1) Loosen 20 fixing bolts(A).
- 2) Remove the oil pan(B).

CAUTION

Remove the gasket on the assembly surface.

42. Remove the oil suction pipe and the oil pump.

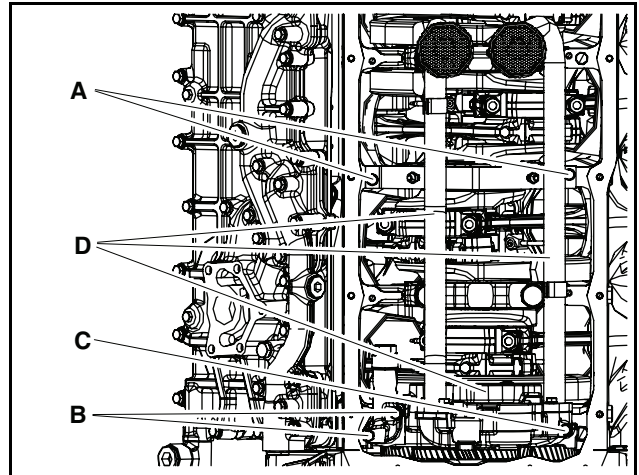

DV2213087A

- 1) Loosen 2 fixing bolts(A).
 - 2) Loosen 2 fixing bolts(B).
 - 3) Loosen the fixing bolt(C).
 - 4) Remove the oil suction pipe and the oil pump(D).
43. Remove the connecting rod and piston assembly.

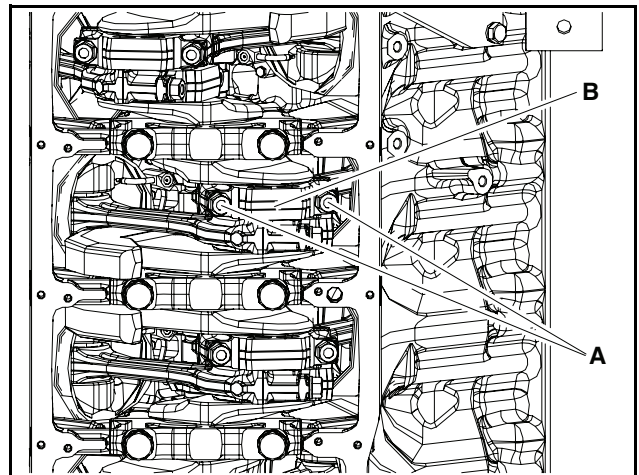

DV2213088A

- 1) Loosen 2 connecting rod bolts and then remove the connecting rod cap(B).
- 2) Push the connectin rod.

5. About the engine

- 3) Remove 12 connecting rod and piston assemblies as the same procedure.

CAUTION

- Be careful not to interference between the crankshaft and the crank weight.
- Be careful not to mix disconnected connecting rods, connecting rod caps, and removed connecting rod bolts as they are set aside.

44. Disassemble the piston from the connecting rod.

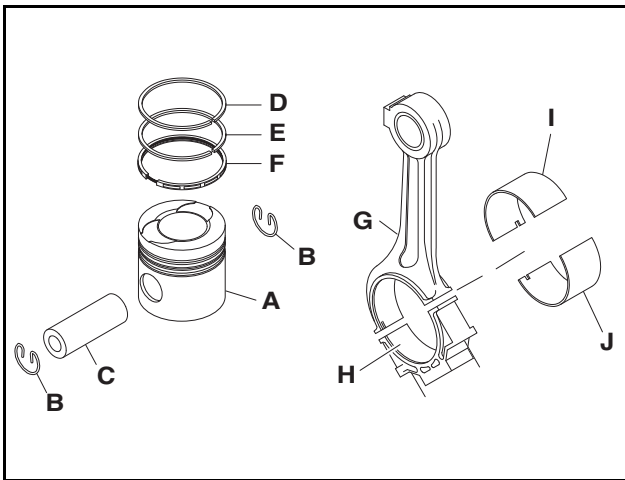

DV2213177A

- 1) Remove 2 snap rings(B) with the snap ring-plier(T7510001E).
- 2) Remove the piston pin(C).
- 3) Remove the piston(A) from connecting rod(G).
- 4) Remove the top ring(D), 2nd ring(E), oil ring(F) with the piston ring plier(T7621010E).
- 5) Remove the upper connecting rod bearing(I) from connecting rod(G).
- 6) Remove the lower connecting rod bearing(J) from connecting rod cap(H).

CAUTION

Be careful not to mix the parts each other.

45. Remove the cylinder liner.

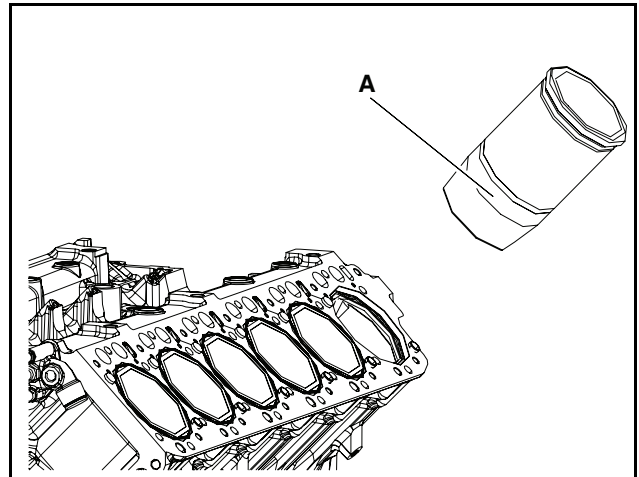

DV2213089A

- 1) Remove the cylinder liner(A) from the cylinder block with the cylinder liner puller(EF.123-365).
- 2) Remove 12 cylinder liners as the same procedure.

46. Change the engine position.

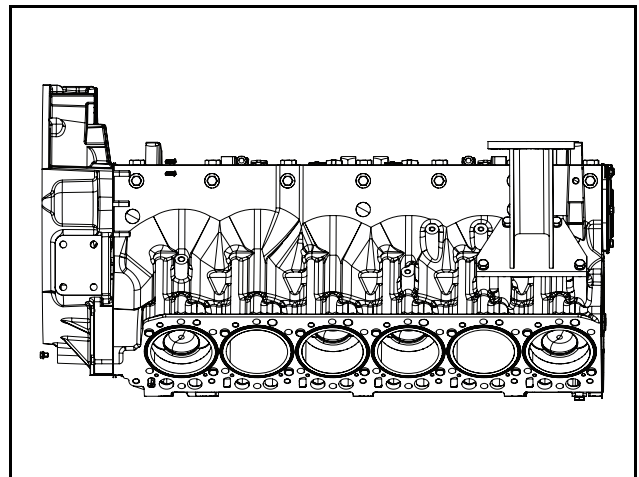

DV2213178A

- 1) Change the engine position. The crankshaft direction is upward.

47. Remove the front oil seal.

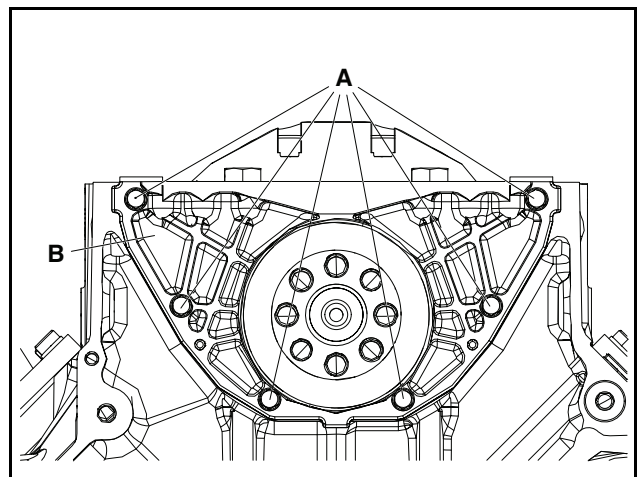

DV2213090A

5. About the engine

- 1) loosen 6 fixing bolts(A).
 - 2) Remove the front oil seal(B).
48. Remove the flywheel.

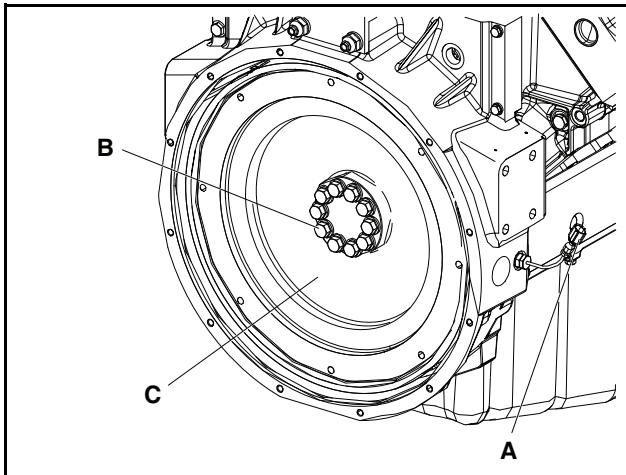

DV2213091A

- 1) Remove the tacho sensor(A).
 - 2) Loosen 10 hex bolts(B) and then remove the flywheel.
49. Remove the flywheel housing.

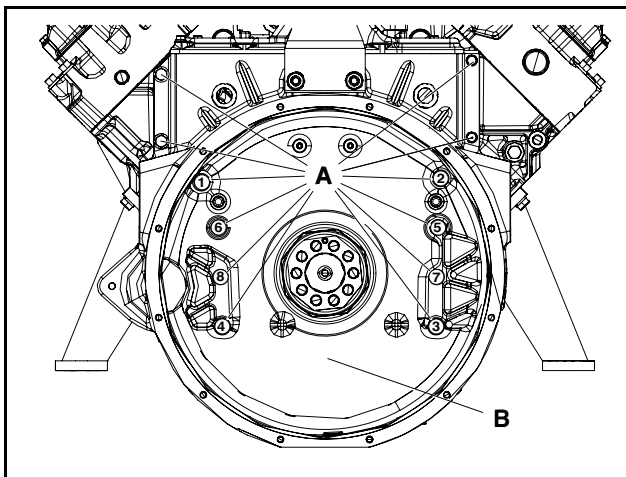

DV2213179A

- 1) Loosen 12 fixing bolts(A).
- 2) Remove the flywheel housing(B).

50. Remove the crankshaft.

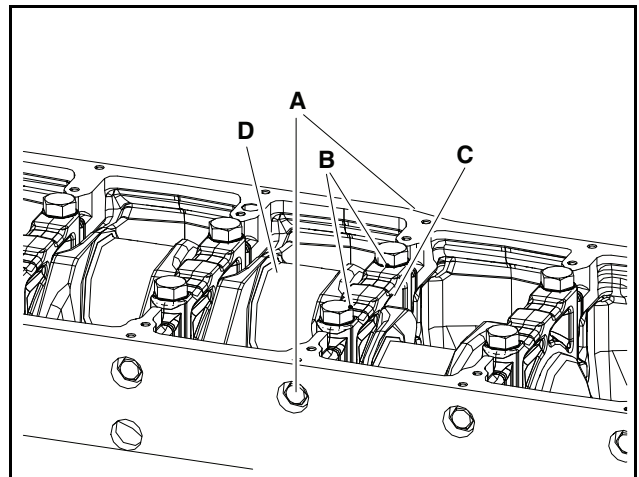

DV2213093A

- 1) Loosen 2 side fixing bolts(A) and 2 bearing cap bolts(B).
- 2) Remove bearing cap(C).
- 3) Remove 12 bearing caps as the same procedure.
- 4) Remove the crankshaft(D).
- 5) Remove the main bearing and the thrust bearing.

CAUTION

Be careful not to lose bearings.

51. Remove the camshaft.

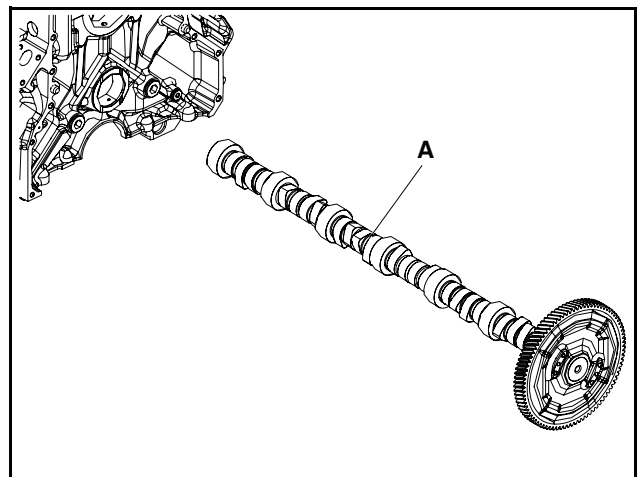

DV2213094A

- 1) Remove the camshaft(A) from cylinder block.

5. About the engine

52. Remove the valve tapet and the spray nozzle.

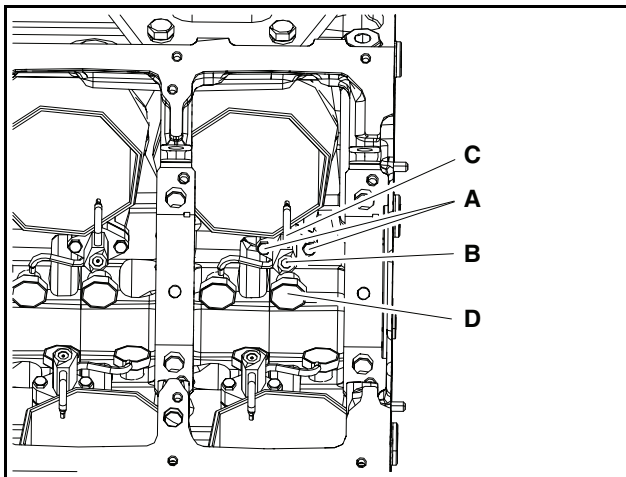

DV2213095A

- 1) Loosen 2 fixing bolts(A) and 1 hollow screw(B).
- 2) Remove the oil spray nozzle(C).
- 3) Remove 12 oil spray nozzles as the same procedure.
- 4) Remove the valve tapet(D).
- 5) Remove 24 valve tapets as the same procedure.

Engine Assembly

Procedure of Assembling Engine

CAUTION

- Cleanse all disassembled and disconnected parts. Especially, clean the oil and coolant path with compressed air and check if there is any resistance.
- Arrange general tools and special tools for engine assembly.
- Prepare clean engine oil to be applied on each sliding component.
- Prepare repair materials such as sealant and gaskets.
- Replace used gaskets, seal rings, and expendable parts with new ones.
- Each bolt should be tightened with the specified tightening torque in the order of tightening; however, excessive tightening torque should be avoided.
- Ensure that all engine parts are successfully operating after reassembly.
- Check if any bolts are loose after the first assembly.
- Always keep hands clean during assembly.

Assemble the engine in the following order.

1. Attach the valve tapet and the oil spray nozzle.

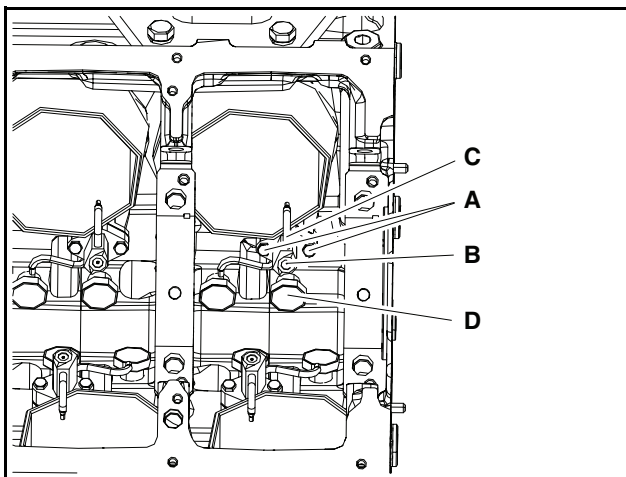

DV2213095A

- 1) Attach the valve tapet(D).
- 2) Attach 24 valve tapets as the same procedure.
- 3) Attach the oil spray nozzle(C).
- 4) Tighten 1 M14 hollow screw(B) at a tightening torque of 7 kgf·m.

- 5) Tighten 2 M6 fixing bolts(A) at a tightening torque of 1.2 kgf·m.
 - 6) Attach 12 oil spray nozzle as the same procedure.
2. Attach the crankshaft.dps

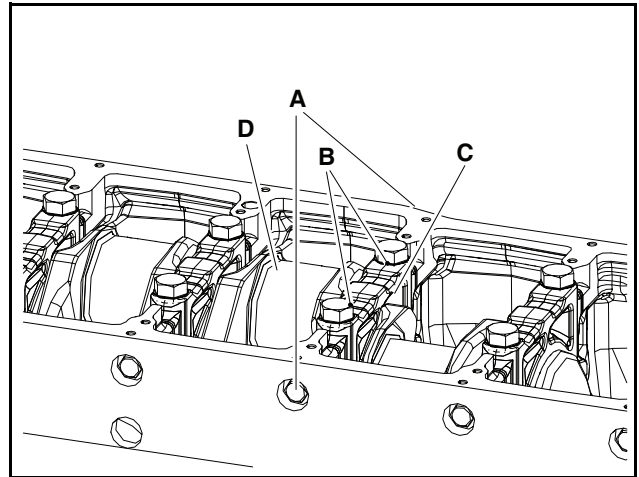

DV2213093A

- 1) Attach the main bearing and the thrust bearing.
 - 2) Attach the crankshaft(D).
 - 3) Attach the bearing cap(C).
 - 4) Attach 12 bearing cap as the same procedure.
 - 5) Tighten M18 bearing cap bolt(B) at a tightening torque of 30 kgf·m + 90° by using the angle method.
3. Attach the camshaft.

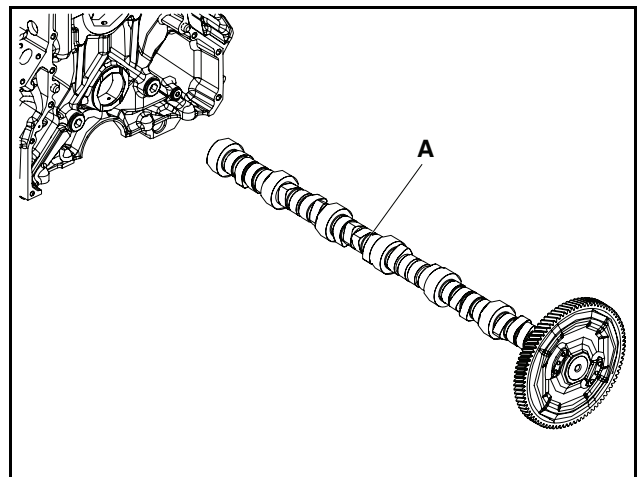

DV2213094A

- 1) Apply engine oil inside cam hole and outside cam journal of the cylinder block.
- 2) Attach the camshaft(A) to the cylinder block.
- 3) Align the cam gear marking to the crankshaft gear marking(Timing mark).

Note) The engraved marks is "1".

5. About the engine

4. Attach the oil seal to the flywheel housing.

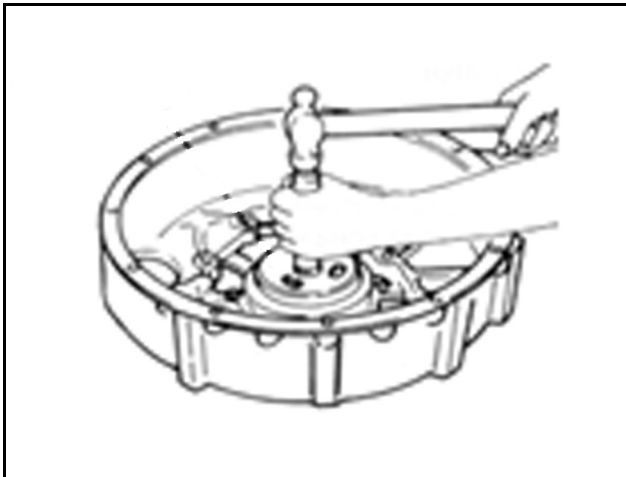

DV2213180A

- 1) Apply engine oil on the surface of the oil seal rotation contact.
- 2) Install the oil seal to the rear oil seal assembly jig(EF.120-029).
- 3) Align the rear oil seal assembly jig with the oil seal hole of the flywheel housing.
- 4) Attach the oil seal to the flywheel housing and beat the rear part of the rear oil seal assembly jig with a rubber hammer.
- 5) Pull off the rear oil seal assembly jig.

⚠ CAUTION

- Be careful not to damage the oil seal.
- Do not reuse the oil seal.

5. Attach the flywheel housing.

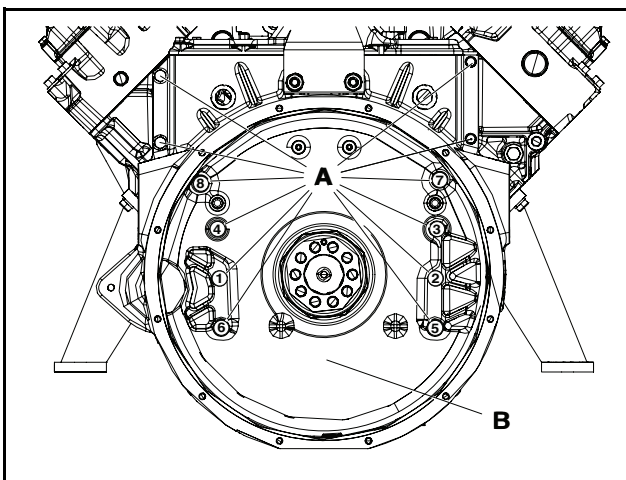

DV2213181A

- 1) Attach the gasket.
- 2) Attach the flywheel housing(B).
- 3) Tighten 12 fixing bolts(A).

- 4) Tighten M12 fixing bolts(A) at a tightening torque of $11.2\text{kgf}\cdot\text{m} \pm 1.5\text{kgf}\cdot\text{m}$ and M10 fixing bolts(A) at a tightening torque of $7.4\text{kgf}\cdot\text{m} \pm 1.0\text{kgf}\cdot\text{m}$.
6. Attach the flywheel wearing.

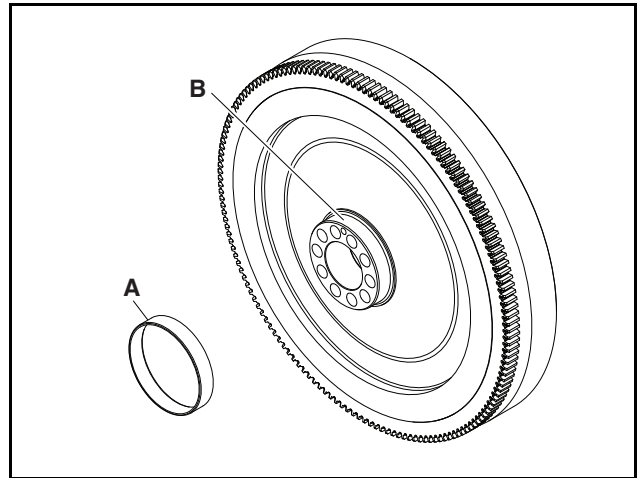

DV2213182A

- 1) Apply LOCTITE 271 on the flywheel surface with the thickness $0.5\text{mm} \sim 1.0\text{mm}$.
- 2) Heat the wearing at $150^{\circ}\text{C} \pm 10^{\circ}\text{C}$ for above 5 minutes.
- 3) Attach the wearing(A) to the flywheel. Align the wearing end with the flywheel end.
7. Attach the flywheel.

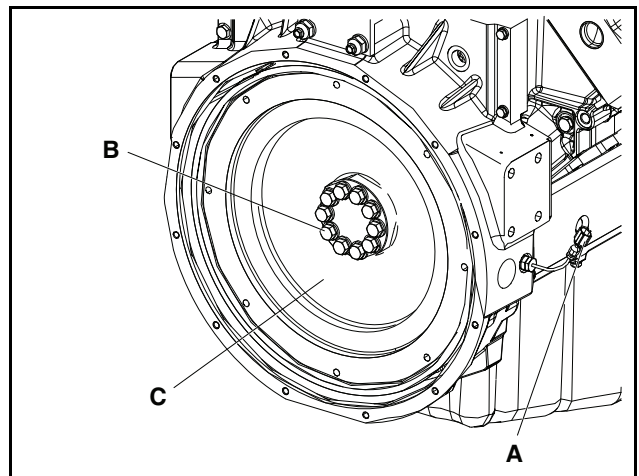

DV2213091A

- 1) Attach the flywheel(C).
- 2) Tighten 10 M16 hex bolts(B) at a tightening torque of $10\text{ kgf}\cdot\text{m} + 90^{\circ} + 90^{\circ}$ by using the angle method.
- 3) Tighten the tachometer sensor(A) at a tightening torque $1.5\text{ kgf}\cdot\text{m} \pm 0.5\text{kgf}\cdot\text{m}$.

Note) The clearance between the tachometer sensor and the flywheel is $1.0\text{mm} \pm 0.1\text{mm}$.

5. About the engine

8. Attach the oil seal to the front oil seal cover.

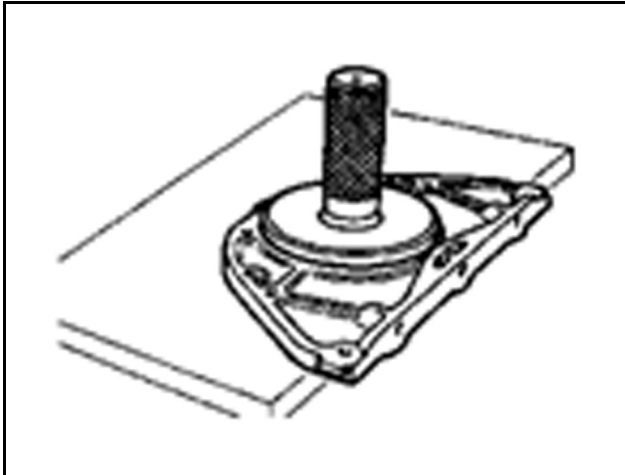

DV2213183A

- 1) Apply engine oil on the surface of the oil seal rotation contact.
- 2) Install the oil seal to the front oil seal assembly jig (EF.120-030).
- 3) Align the front oil seal assembly jig with the oil seal hole of the front oil seal cover.
- 4) Attach the oil seal to the front oil seal cover and beat the rear part of the front oil seal assembly jig with a rubber hammer.
- 5) Pull off the front oil seal assembly jig.

CAUTION

- Be careful not to damage the oil seal.
- Do not reuse the oil seal.

9. Attach the front oil seal cover.

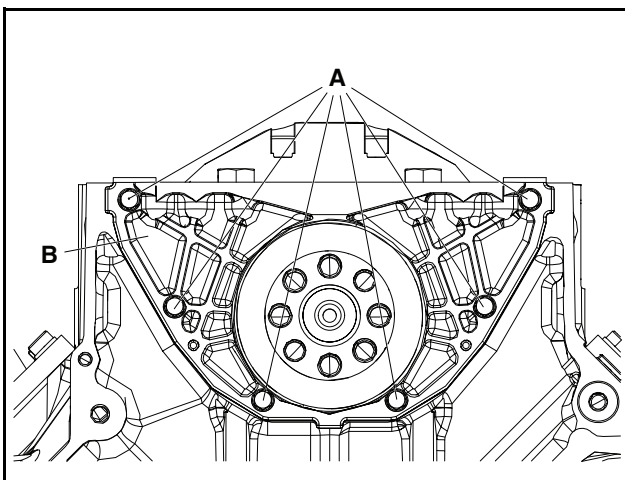

DV2213090A

- 1) Attach the front oil seal cover(B).
- 2) Tighten 6 M8 fixing bolts(A) at a tightening torque 2.24 kgf·m.

10. Change the engine position.

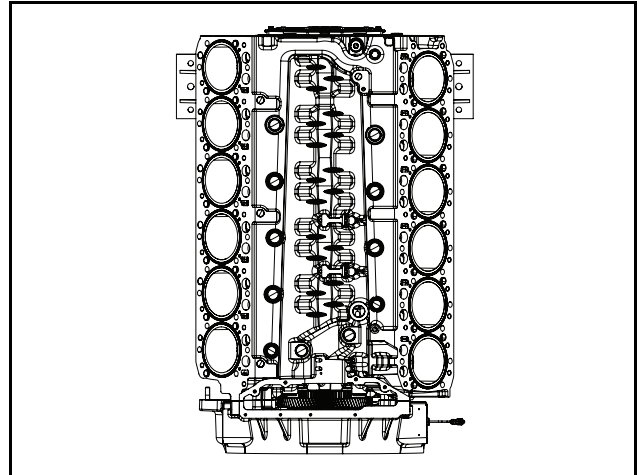

DV2213184A

- 1) Change the engine position. The flywheel direction is downward.

11. Attach the cylinder liner.

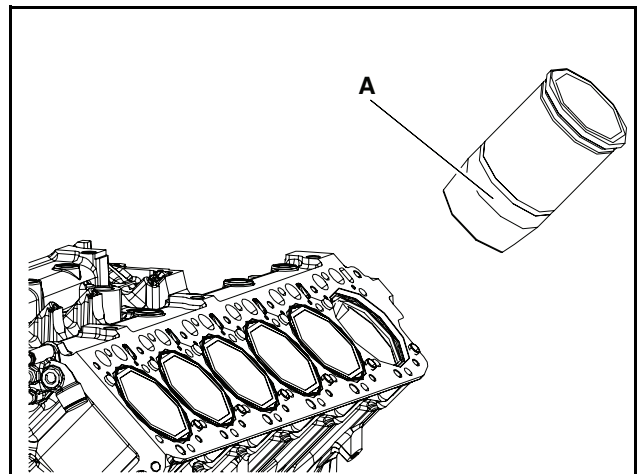

DV2213089A

- 1) Apply engine oil on the surface of the cylinder liner.
- 2) Attach the cylinder liner(A) to the cylinder block with the cylinder liner puller(EF.123-365).
- 3) Attach 12 cylinder liners as the same procedure.

5. About the engine

12. Attach the piston to the connecting rod.

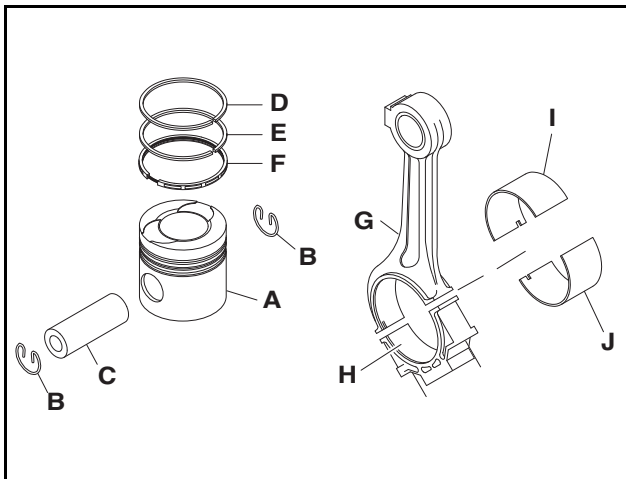

DV2213177A

1) Install the 1st ring(D), 2nd ring(E), and the oil ring(F) with the piston ring plier(T7621010E).

⚠ CAUTION

- Ensure that the 'Y' mark of the piston ring faces the top surface of the piston.
- Make the piston ring position dislocated to 120°

2) Apply engine oil on the piston pin(C).

3) Align the pin hole of the connecting rod(G) small-end with that of the piston(A).

⚠ CAUTION

- The intake valve pocket is larger than the exhaust valve pocket.
- Attach the engine as the same piston weight. Place the Class of the piston weight on the top surface of the piston.

CLASS	Piston Weight(g)
A	2,371 ~ 2,380
B	2,381 ~ 2,390
C	2,391 ~ 2,400
D	2,401 ~ 2,410
E	2,411 ~ 2,420

4) Attach the piston pin(C).

⚠ CAUTION

Check the attached piston and piston ring. If the piston should be replaced, replace the piston pin along with the piston.

5) Attach 2 snap rings(B) with the snap ring plier (T7610001E).

⚠ CAUTION

- Do not reuse the snap rings.
- Assemble snap rings with the opening of the snap rings facing 12 o'clock.

6) Align the upper bearing groove with connecting rod. Attach the upper connecting rod bearing(I) to the connecting rod(G).

7) Align the lower bearing groove with connecting rod. Attach the lower connecting rod bearing(J) to the connecting rod bearing cap(H).

⚠ CAUTION

- Be careful the direction when assembling the connecting rods and the connecting rod caps.
- Ensure that the marks of the connecting rod and the bearing cap are facing the same direction.

13. Attach the connecting rod and piston assembly.

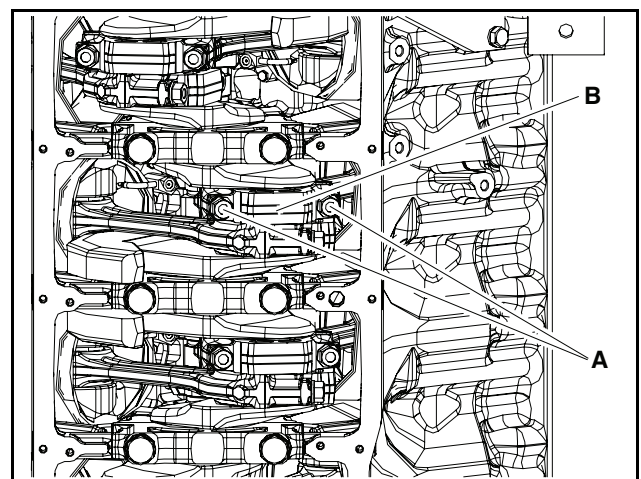

DV2213088A

1) Attach the connecting rod and piston assembly to the cylinder block.

2) Attach the connecting rod cap(B).

3) Tighten 2 M16X1 flange hex bolts(A) at a tightening torque 10 kgf·m + 90° by using the angle method.

5. About the engine

- 4) Attach 12 connecting rod and piston assembly as the same procedure.

CAUTION

- Be careful to note the direction when attaching the connecting rods and the connecting rod caps. Ensure that the number engraved on the connecting rods is same with that engraved on the connecting rod caps and the assembly direction is same.
- Attach the connecting rod and piston assembly without contacting the crankshaft weight. Rotate the crankshaft.

14. Attach the oil suction pipe and the oil pump.

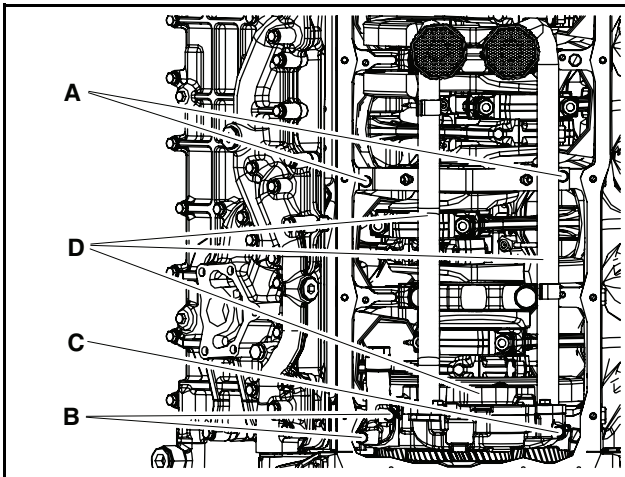

DV2213087A

- 1) Attach the oil suction pipe and the oil pump(D).
- 2) Tighten M8 fixing bolt(C) at a tightening torque 2.2 kgf·m.
- 3) Tighten 2 M8 fixing bolts(B) at a tightening torque 2.2 kgf·m.
- 4) Tighten 2 M8 fixing bolt(A) at a tightening torque 2.2 kgf·m.

15. Attach the oil pan.

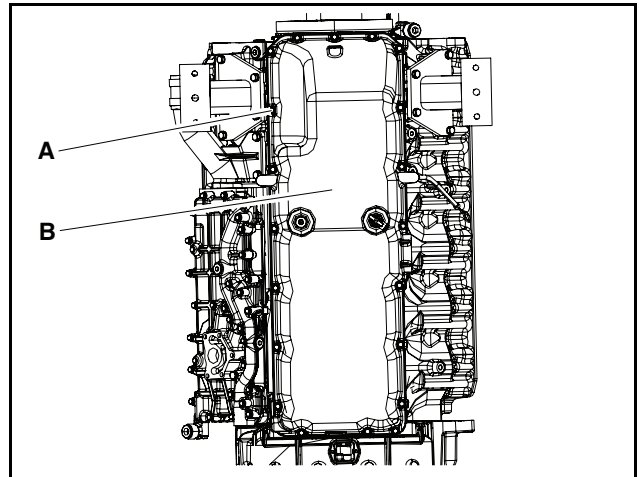

DV2213086A

- 1) Attach the oil pan(B).
 - 2) Tighten 20 M8 fixing bolts(A) at a tightening torque 2.2 kgf·m \pm 0.33kgf·m.
16. Change the engine position.

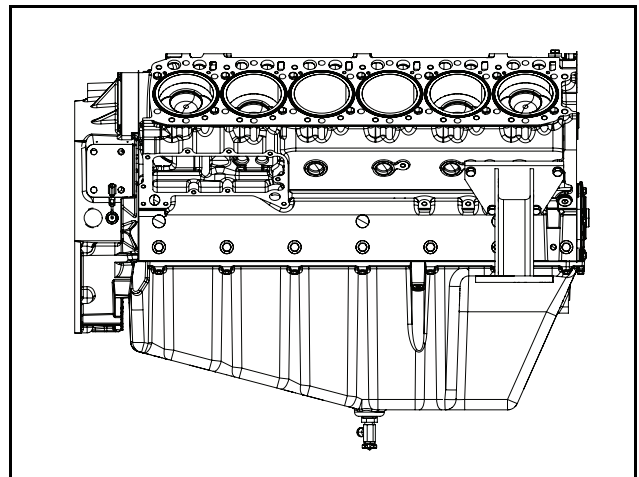

DV2213185A

- 1) Change the engine position. The piston direction is upward.
17. Adjust the fuel injection timing.

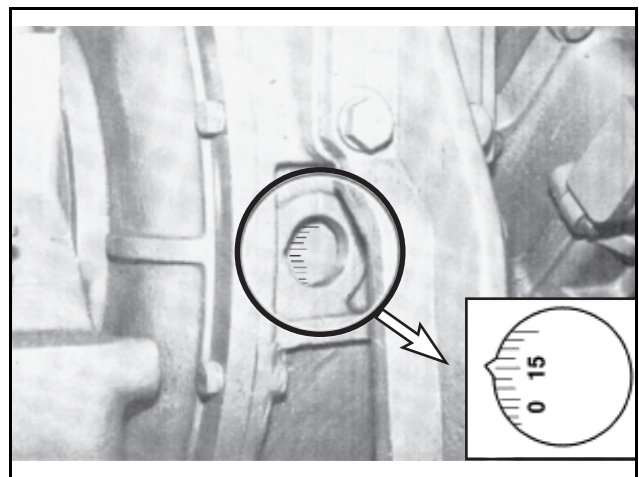

DV2213027A

5. About the engine

- 1) Rotate the crankshaft so that the #1 cylinder piston may be positioned at the top dead center(OT) and the #6 cylinder piston may be positioned at the valve overlap.

Note) In case of 8/12 cylinder engine, #6. cylinder is positioned at the valve overlap when #1. cylinder is positioned at the compression TDC(Top Dead Center).

Note) In case of 10 cylinder engine, #7. cylinder is positioned at the valve overlap when #1. cylinder is positioned at the compression TDC(Top Dead center).

- 2) Rotate the crankshaft until the yellow mark of the camshaft gear is not shown.
- 3) Adjust the fuel injection timing with rotating the flywheel to the engine rotating direction.

Engine Model		Fuel Injection Timing (°)
DP158L	DP158LCS	23° ± 1°
	DP158LCF	18° ± 1°
	DP158LDS	23° ± 1°
	DP158LDF	18° ± 1°
DP180L	DP180LBS	21° ± 1°
	DP180LBF	19° ± 1°
	DP180LAS	21° ± 1°
	DP180LAF	19° ± 1°
DP222L	DP222LAS	21° ± 1°
	DP222LBS	21° ± 1°
	DP222LBF	19° ± 1°
	DP222LCS	21° ± 1°
	DP222LCF	19° ± 1°

18. Attach the fuel injection driven gear temporarily.

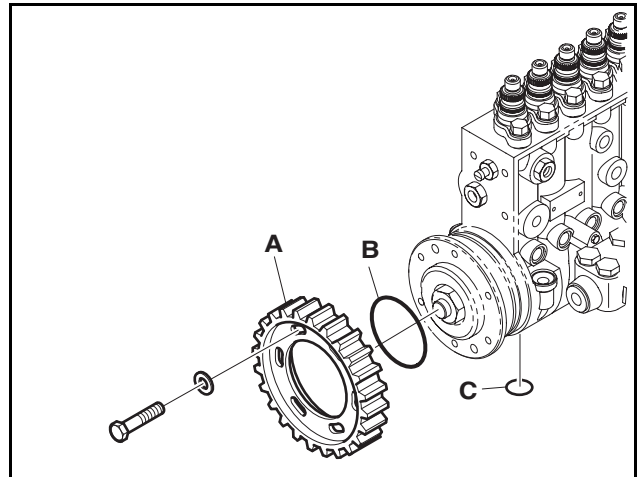

DV2213186A

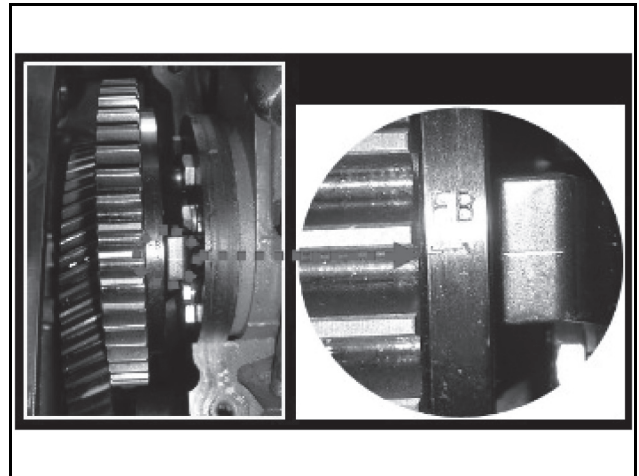

DV2213171A

- 1) Attach the driven gear(A) to the fuel injection pump temporarily.
- 2) Attach the O-ring(B) and (C) to the fuel injection pump.
- 3) Align the injection timing pointer of the fuel injection pump driven gear with the marking on the cylindrical surface.

5. About the engine

19. Attach the fuel injection pump.

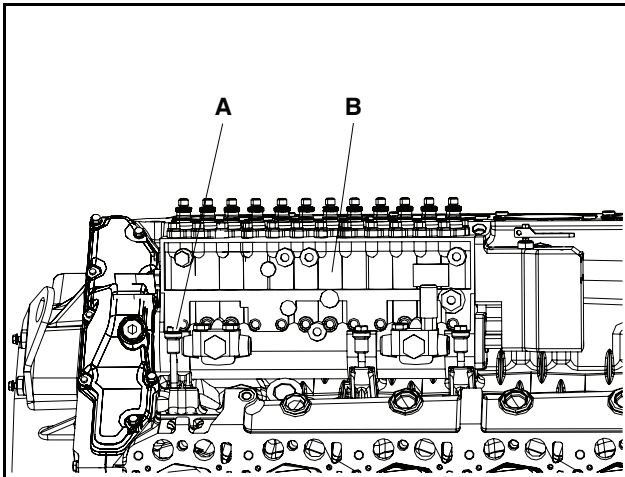

DV2213072A

- 1) Attach the fuel injection pump(B) with the injection pump alignment jig(EF.120-189).
- 2) Tighten 6 fixing bolts(A) at a tightening torque 5.0 kgf·m \pm 0.5kgf·m.

20. Attach the fuel injection pump driven gear.

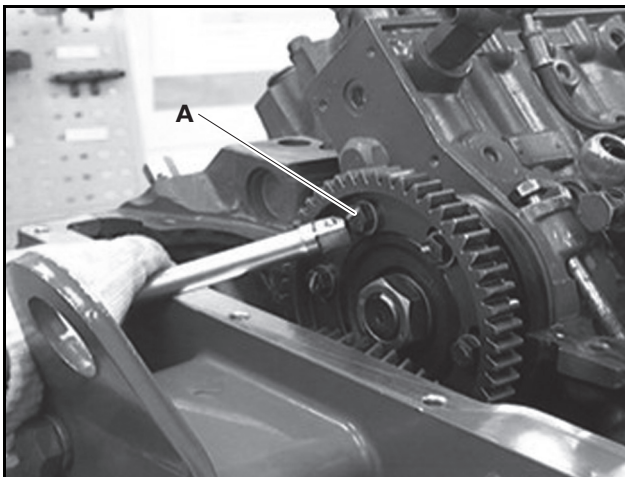

DV2213187A

- 1) Tighten 3 M8 fixing bolts(A) of the fuel injection pump driven gear at a tightening torque 3.1 kgf·m \pm 0.46kgf·m.
- 2) Rotate the fuel injection pump driven gear 360° with rotating flywheel.
- 3) Tighten 3 the other M8 fixing bolts(A) of the fuel injection pump driven gear at a tightening torque 3.1 kgf·m \pm 0.46kgf·m.

21. Attach the flywheel housing cover.

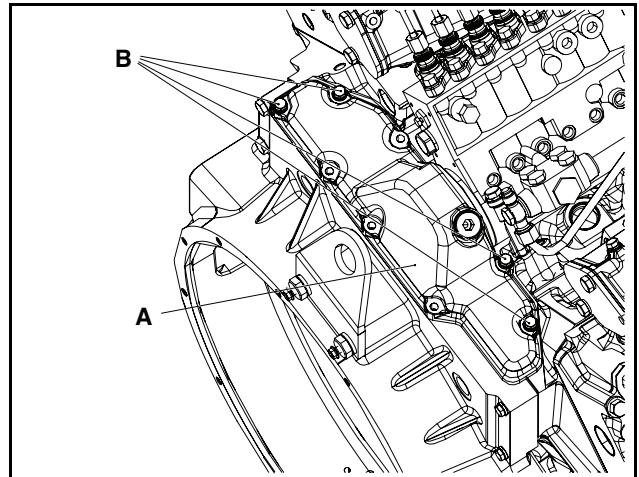

DV2213188A

- 1) Attach the flywheel housing cover(A).
- 2) Tighten 4 M8 fixing bolts(B) at a tightening torque 2.2 kgf·m \pm 0.3kgf·m.

22. Attach the cylinder head.

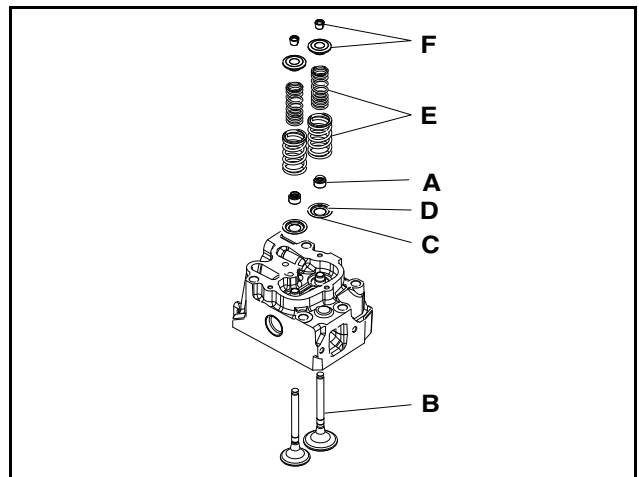

DV2213189A

- 1) Attach the inner washer(C) and the outer washer(D).
- 2) Attach the valve stem seal(A) with the valve stem seal punch(EF.120-183).

CAUTION

Do not give an excessive shock on the valve stem seals; otherwise, they may be damaged.

5. About the engine

- 3) Attach the valve(B).

⚠ CAUTION

Be careful to use the right valve without confusing the intake valve with the exhaust valve. The intake valve is the mark " I " engraved on the head and the exhaust valve is the mark " E " engraved on the head.

- 4) Attach the valve spring(E).

⚠ CAUTION

Be careful the valve direction. The yellow mark on the valve is upward.

- 5) Compress the valve with the valve spring press (EF.120-262).
- 6) Attach the valve cotters(F).

⚠ CAUTION

Check if the valve cotters have been positioned correctly with the plastic hammer after completing attaching them.

23. Attach the cylinder head assembly.

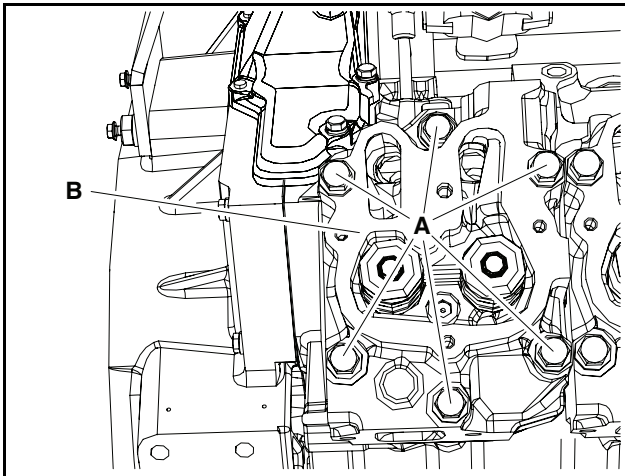

DV2213077A

- 1) Attach the gasket assembly.
- 2) Attach the cylinder head assembly(B).
- 3) Tighten 6 cylinder head fixing bolts(A) at a tightening torque $8\text{kgf}\cdot\text{m} + 15\text{kgf}\cdot\text{m} + 90^\circ + 90^\circ$ by using the angle method.
- 4) Attach 12 cylinder head assembly as the same procedure.

24. Attach the push rods.

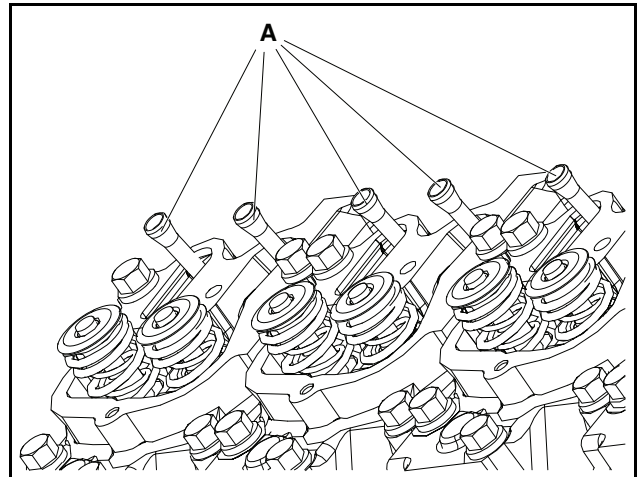

DV2213076A

- 1) Attach 24 push rods(A).
25. Attach the rocker arm assembly.

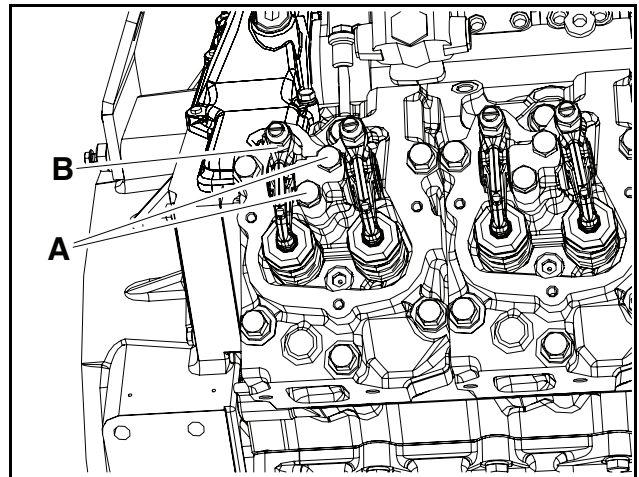

DV2213075A

- 1) Attach the rocker arm assembly(B).
- 2) Tighten the fixing bolts(A).
- 3) Attach 12 rocker arms as the same procedure.
26. Attach the injectors.

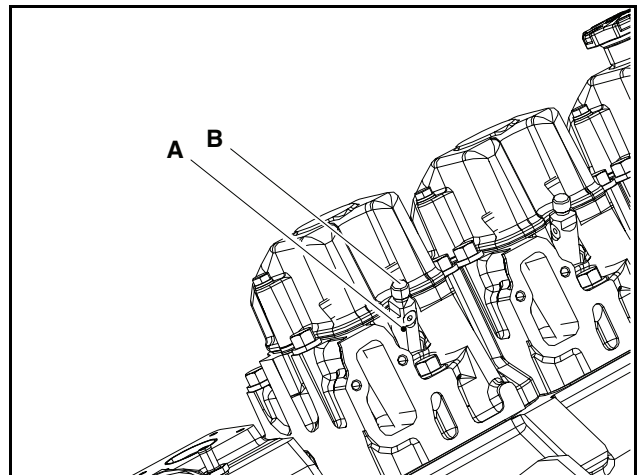

DV2213073A

5. About the engine

- 1) Attach the seal ring and then attach the injector(A).
- 2) Tighten the injector holder fixing nut with the jig for injection nozzle detach(60.99901-0036).
- 3) Attach 12 injectors as the same procedure.

⚠ CAUTION

Be careful not to damage the fuel pipes.

27. Attach the fuel return pipe.

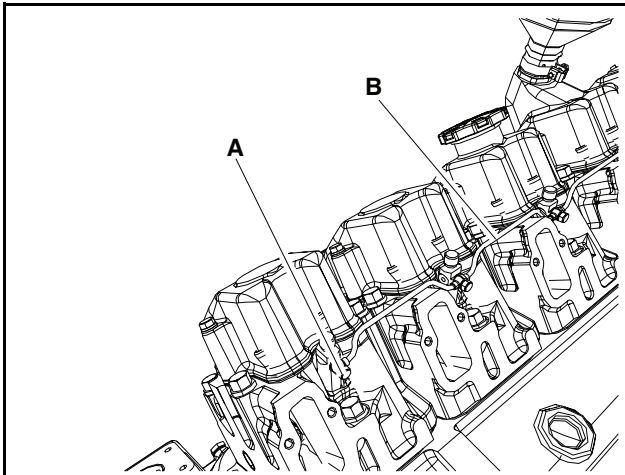

DV2213069A

- 1) Attach the fuel return pipe(B).
- 2) Attach the double seal ring.
- 3) Tighten the hollow screw(A) at a tightening torque $0.8\text{kgf}\cdot\text{m} \pm 0.12\text{kgf}\cdot\text{m}$.
- 4) Attach the other fuel return pipe as the same procedure.

28. Adjust the valve clearance. (Method 1)

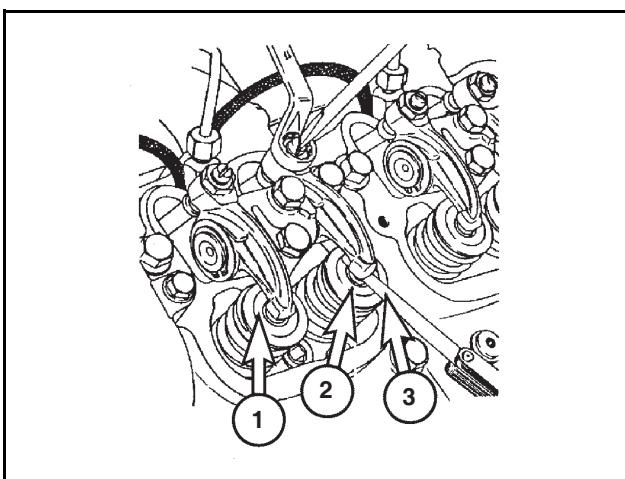

DV2213041A

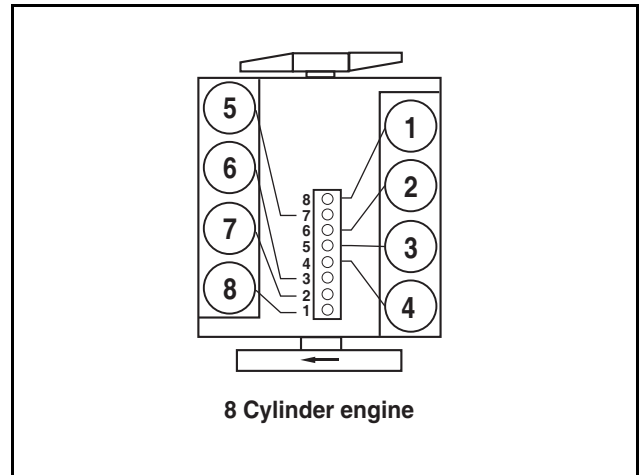

DV2213042A

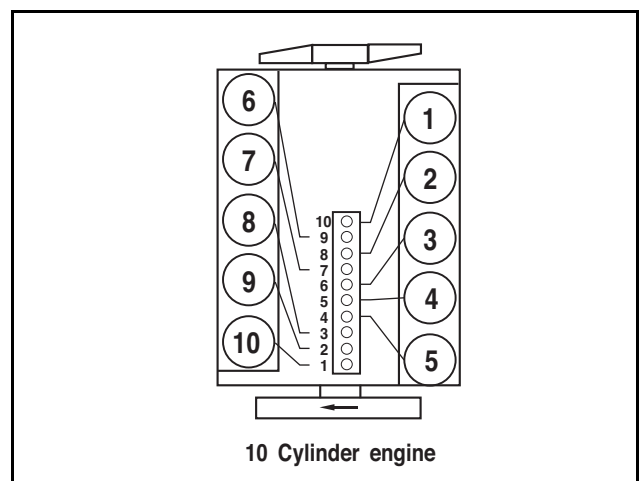

DV2213213A

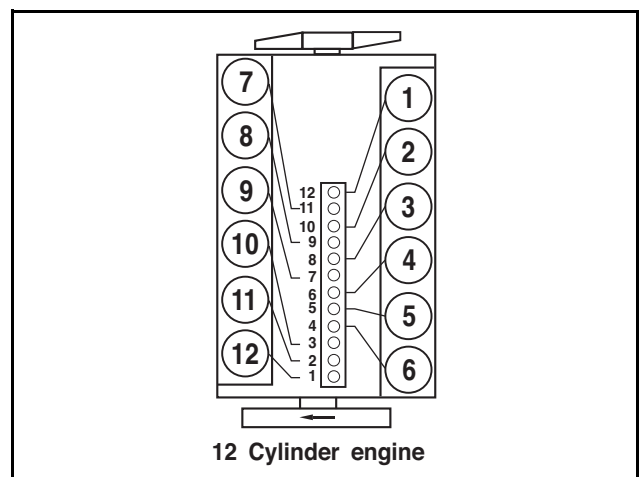

DV2213043A

- 1) Rotate the crankshaft so that #1. cylinder may be positioned at the compression TDC(Top Dead Center).
Note) #1. Cylinder is located at the side where cooling water pump was installed.

Note) In case of 8/12 cylinder engine, #6. cylinder is positioned at the valve overlap when #1. cylinder is positioned at the compression TDC(Top Dead Center).

5. About the engine

Note) In case of 10 cylinder engine, #7. cylinder is positioned at the valve overlap when #1. cylinder is positioned at the compression TDC(Top Dead center).

- 2) Loosen the lock nut of the #1. cylinder rocker arm.
- 3) Push the feeler gauge between a rocker arm and a valve stem.
- 4) Adjust the clearance screw respectively and then tighten with the lock nut.
- 5) As for the valve clearance, adjust it when in cold, as follows.

Engine Model		In. valve	Ex. valve
DP158L	DP158LCS	0.25mm	0.35mm
	DP158LCF	0.25mm	0.35mm
	DP158LDS	0.25mm	0.35mm
	DP158LDF	0.25mm	0.35mm
DP180L	DP180LBS	0.25mm	0.35mm
	DP180LBF	0.25mm	0.35mm
	DP180LAS	0.25mm	0.35mm
	DP180LAF	0.25mm	0.35mm
DP222L	DP222LAS	0.25mm	0.35mm
	DP222LBS	0.25mm	0.35mm
	DP222LBF	0.25mm	0.35mm
	DP222LCS	0.25mm	0.35mm
	DP222LCF	0.25mm	0.35mm

- 6) Rotate the crankshaft. When a cylinder reaches the compression TDC(Top Dead Center), adjust the valve clearance of the cylinder.
- 7) When a cylinder valve overlap, adjust the valve clearance cylinder of the compression TDC(Top Dead Center), as follow.
 - 8 cylinder engine(DP158L)

Valve overlap cylinder No.							
1	5	7	2	6	3	4	8
6	3	4	8	1	5	7	2
Adjusting valve cylinder No. (In./Ex. Valve)							

- 10 cylinder engine(DP180L)

Valve overlap cylinder No.									
1	6	5	10	2	7	3	8	4	9
7	3	8	4	9	1	6	5	10	2
Adjusting valve cylinder No. (In./Ex. Valve)									

- 12cylinder engine(DP222L)

Valve overlap cylinder No.											
1	12	5	8	3	10	6	7	2	11	4	9
6	7	2	11	4	9	1	12	5	8	3	10
Adjusting valve cylinder No. (In./Ex. Valve)											

29. Adjust the valve clearance. (Method 2)

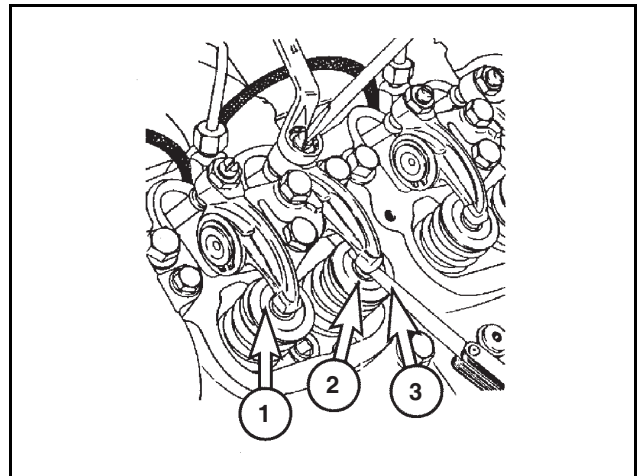

DV2213041A

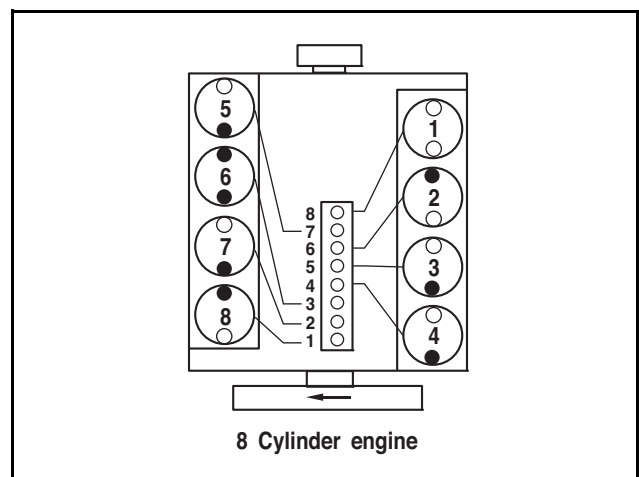

DV2213208A

5. About the engine

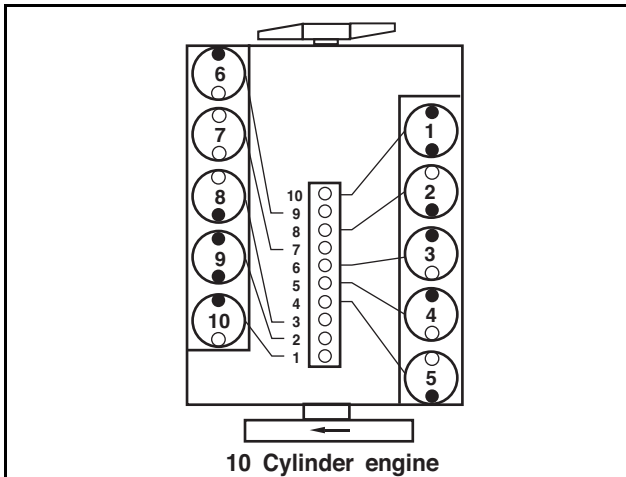

DV2213214A

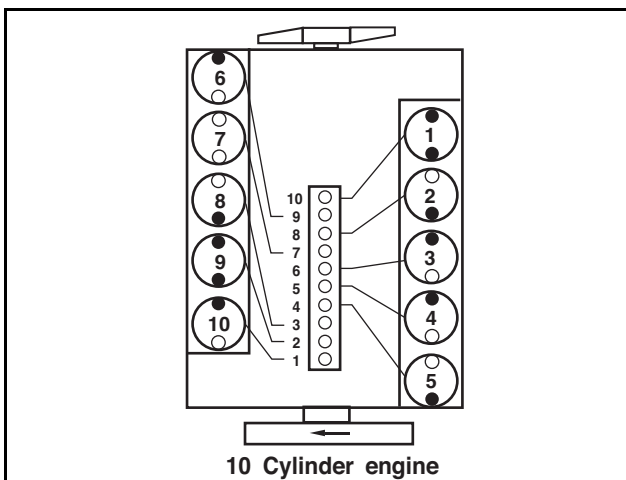

DV2213214A

- 1) By cranking the engine, let the cylinder No. 7 on the overlap TDC in 10 cylinder engine (but 8 & 10 cylinder engine is No. 6) that is, cylinder No. 1 becomes the ignition TDC position. Then adjust the valves corresponding to mark "○" in the below figure.

Note) #1. Cylinder is located at the side where cooling water pump was installed.

- 2) After that, turn the crankshaft one rotation (360°) clockwise, put the cylinder No. 1 on overlap TDC position that is, cylinder No. 7 (but 8 & 10 cylinder engine is No. 6) becomes the ignition TDC position. Then adjust the valves corresponding to "●" in the below figure.

Note) In case of 8/12 cylinder engine, #6. cylinder is positioned at the valve overlap when #1. cylinder is positioned at the compression TDC(Top Dead Center).

Note) In case of 10 cylinder engine, #7. cylinder is positioned at the valve overlap when #1. cylinder is positioned at the compression TDC(Top Dead center).

Engine Model		In. valve	Ex. valve
DP158L	DP158LCS	0.25mm	0.35mm
	DP158LCF	0.25mm	0.35mm
	DP158LDS	0.25mm	0.35mm
	DP158LDF	0.25mm	0.35mm
DP180L	DP180LBS	0.25mm	0.35mm
	DP180LBF	0.25mm	0.35mm
	DP180LAS	0.25mm	0.35mm
	DP180LAF	0.25mm	0.35mm
DP222L	DP222LAS	0.25mm	0.35mm
	DP222LBS	0.25mm	0.35mm
	DP222LBF	0.25mm	0.35mm
	DP222LCS	0.25mm	0.35mm
	DP222LCF	0.25mm	0.35mm

- 8 cylinder engine(DP158L)

Cylinder No.	1		2		3		4	
Valve	In	Ex	In	Ex	In	Ex	In	Ex
#1TDC	●	●	○	●	○	○	●	○
#6TDC								
Cylinder No.	5		6		7		8	
Valve	In	Ex	In	Ex	In	Ex	In	Ex
#1TDC	○	●	○	○	○	●	●	○
#6TDC								

- 10 cylinder engine(DP180L)

Cylinder No.	1		2		3		4		5	
Valve	In	Ex	In	Ex	In	Ex	In	Ex	In	Ex
#1TDC	●	●	○	●	●	○	●	○	○	●
#7TDC										
Cylinder No.	6		7		8		9		10	
Valve	In	Ex	In	Ex	In	Ex	In	Ex	In	Ex
#1TDC	●	○	○	○	○	●	●	●	●	○
#7TDC										

- 12 cylinder engine(DP222L)

5. About the engine

Cylinder No.	1		2		3		4	
Valve	In	Ex	In	Ex	In	Ex	In	Ex
#1TDC #6TDC	•	•	•	○	○	•	•	○
Cylinder No.	5		6		7		8	
Valve	In	Ex	In	Ex	In	Ex	In	Ex
#1TDC #6TDC	○	•	○	○	○	○	•	○
Cylinder No.	9		10		11		12	
Valve	In	Ex	In	Ex	In	Ex	In	Ex
#1TDC #6TDC	•	•	○	○	○	•	•	•

30. Attach the cylinder head cover.

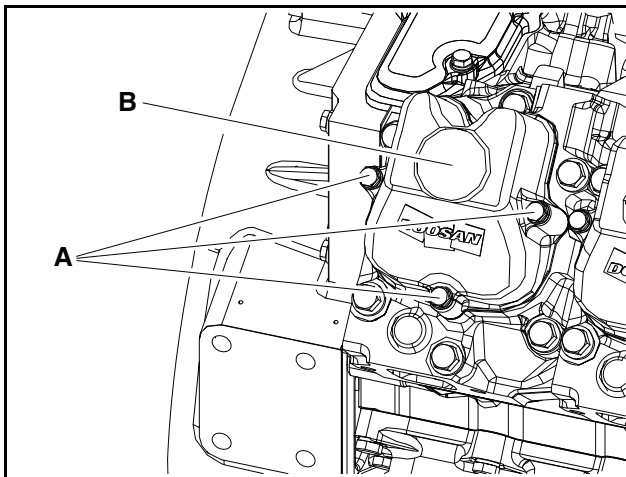

DV2213074A

- 1) Attach the cylinder head cover(B).
- 2) Tighten 3 fixing bolts(A) at a tightening torque 2.2kgf·m ±0.33kgf·m.

⚠ CAUTION

#3 and #4 cylinder head covers have the breather.
#10 cylinder head cover has the oil filler cap. the others are the same cylinder head cover.

31. Attach the breather.

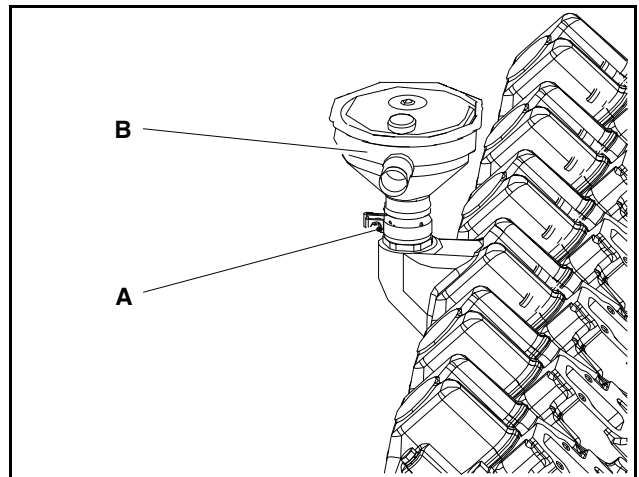

DV2213096A

- 1) Attach the breather(B).
- 2) Tighten the clamp.
- 3) Attach the other breather as the same procedure.

32. Attach the intake manifold.

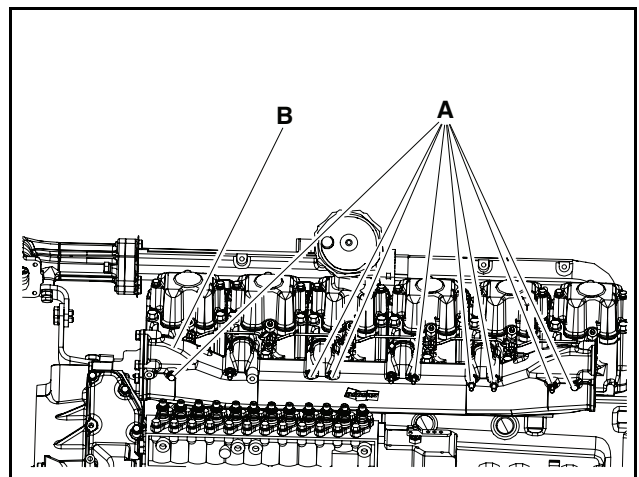

DV2213066A

- 1) Attach the intake manifold(B).
- 2) Tighten the fixing bolts(A) by hand temporarily.
- 3) Tighten the fixing bolts(A) at a tightening torque 2.2kgf·m ± 0.33kgf·m.
- 4) Attach the other intake manifold as the same procedure.

⚠ CAUTION

- Be careful not to let dust inside the engine.
- Be careful not to mix the fixing bolts.

5. About the engine

33. Attach the fuel pre filter.

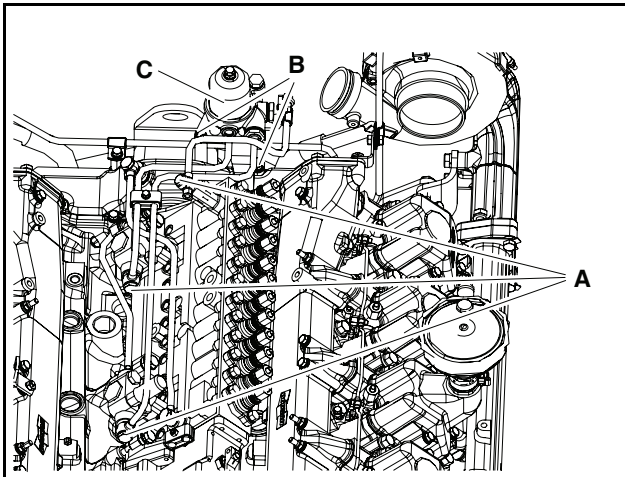

DV2213065A

- 1) Attach the fuel return pipe and fuel pre filter(C).
- 2) Tighten the fixing bolts(B) at a tightening torque $2.2\text{kgf}\cdot\text{m} \pm 0.33\text{kgf}\cdot\text{m}$.
- 3) Tighten the hollow screw(A) at a tightening torque $1.2\text{kgf}\cdot\text{m} \pm 0.14\text{kgf}\cdot\text{m}$.

CAUTION

Be careful not to damage the fuel pipes.

35. Attach the fuel pipe.

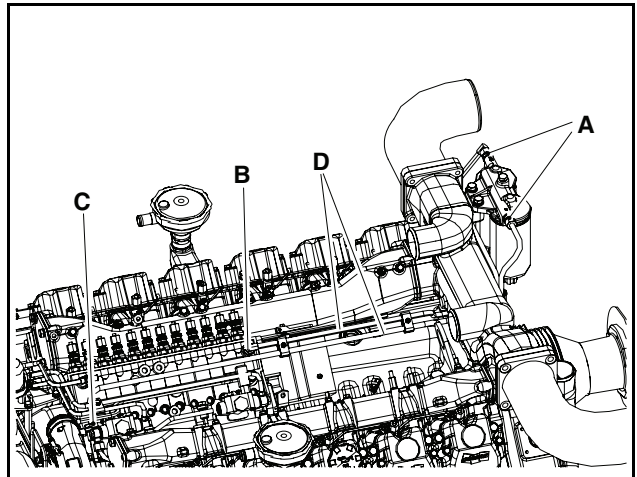

DV2213068A

- 1) Attach the fuel pipe(D).
- 2) Tighten the fixing nut(B) and (C) at a tightening torque $5.5\text{kgf}\cdot\text{m} \pm 0.825\text{kgf}\cdot\text{m}$.
- 3) Tighten the fixing nut(A) at a tightening torque $5.5\text{kgf}\cdot\text{m} \pm 0.825\text{kgf}\cdot\text{m}$.

CAUTION

Be careful not to damage the fuel pipes.

34. Attach the fuel and oil hose.

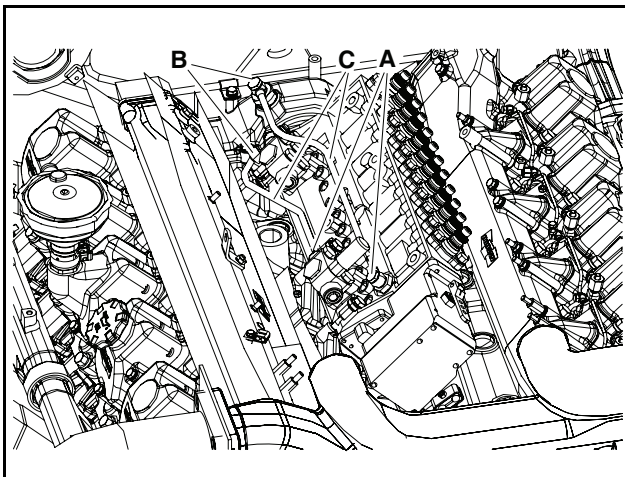

DV2213070A

- 1) Attach the fuel and oil hose(C).
- 2) Tighten the hollow screw(B) at a tightening torque $1.8\text{kgf}\cdot\text{m} \pm 0.27\text{kgf}\cdot\text{m}$.
- 3) Tighten the fixing bolts(A) at a tightening torque $1.8\text{kgf}\cdot\text{m} \pm 0.27\text{kgf}\cdot\text{m}$.

36. Attach the fuel pipe.

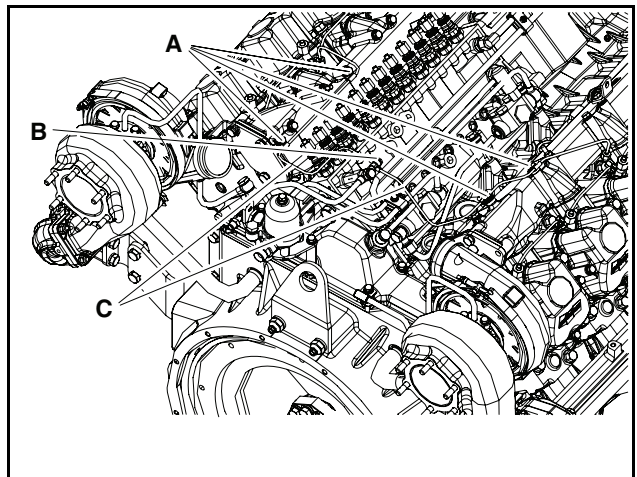

DV2213067A

- 1) Attach the fuel pipe(C).
- 2) Tighten the hollow screw(B) at a tightening torque $1.2\text{kgf}\cdot\text{m} \pm 0.14\text{kgf}\cdot\text{m}$.
- 3) Tighten the fixing bolt(A) at a tightening torque $2.2\text{kgf}\cdot\text{m} \pm 0.33\text{kgf}\cdot\text{m}$.

CAUTION

- Be careful not to lose the O-ring.
- Be careful not to damage the fuel pipes.

5. About the engine

37. Attach the fuel injection pipe.

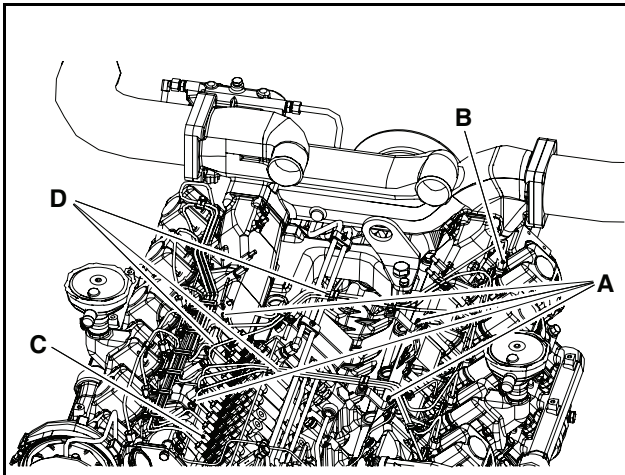

DV2213064A

- 1) Attach 3 fuel injection pipe assemblies(D).
- 2) Attach the fuel pipe nut temporarily.
- 3) Tighten 12 fuel pipe nuts(A) of the injection pump at a tightening torque $5.5\text{kgf}\cdot\text{m} \pm 0.825\text{kgf}\cdot\text{m}$.
- 4) Tighten 12 fuel pipe nuts(A) of the injector at a tightening torque $5.5\text{kgf}\cdot\text{m} \pm 0.825\text{kgf}\cdot\text{m}$.
- 5) Tighten the fixing bolt(A).

CAUTION

- Be careful not to damage the fuel pipes.
- Be careful not to let dust inside the engine.

38. Attach the inlet pipe.

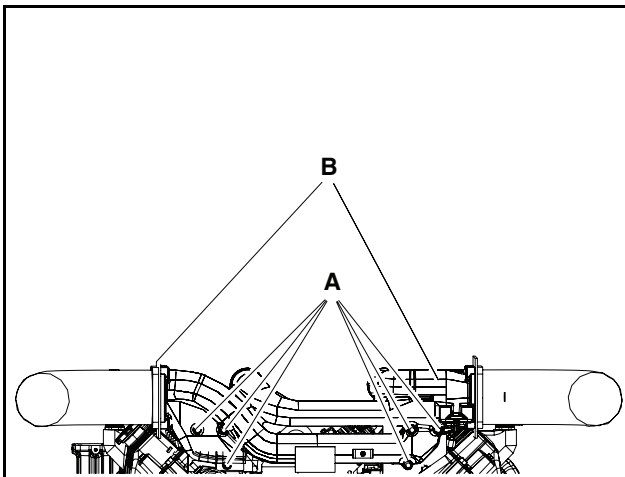

DV2213063A

- 1) Attach the inlet pipe(B).
- 2) Tighten the fixing bolt(A) at a tightening torque $4.4\text{kgf}\cdot\text{m} \pm 0.66\text{kgf}\cdot\text{m}$.

Note) Tighten the fixing bolts to attach the inlet elbow and the inlet pipe at a tightening torque $2.2\text{kgf}\cdot\text{m} \pm 0.33\text{kgf}\cdot\text{m}$.

CAUTION

Be careful not to let dust inside the engine.

39. Attach the fuel filter.

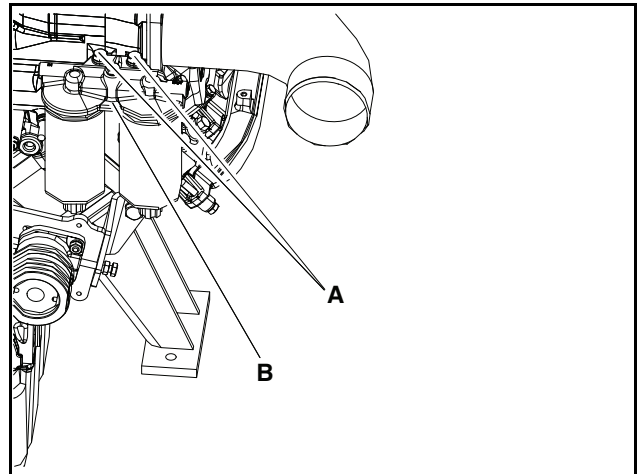

DV2213062A

- 1) Attach the fuel filter assembly(B).
- 2) Tighten the fixing bolt(A) at a tightening torque $7.5\text{kgf}\cdot\text{m} \pm 1.12\text{kgf}\cdot\text{m}$.

40. Attach the intake stake.

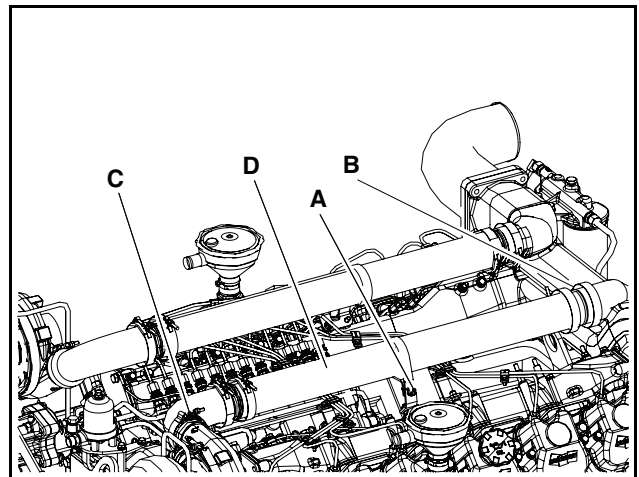

DV2213061A

- 1) Attach the intake stake(D).
- 2) Tighten the V-clamp(C).
- 3) Tighten the hose clamp(B).
- 4) Tighten the fixing bolt(A) at a tightening torque $2.2\text{kgf}\cdot\text{m} \pm 0.33\text{kgf}\cdot\text{m}$.

5. About the engine

5) Attach the other intake stake as the same procedure.

CAUTION

Be careful not to let dust inside the engine.

41. Attach the exhaust manifold and exhaust elbow.

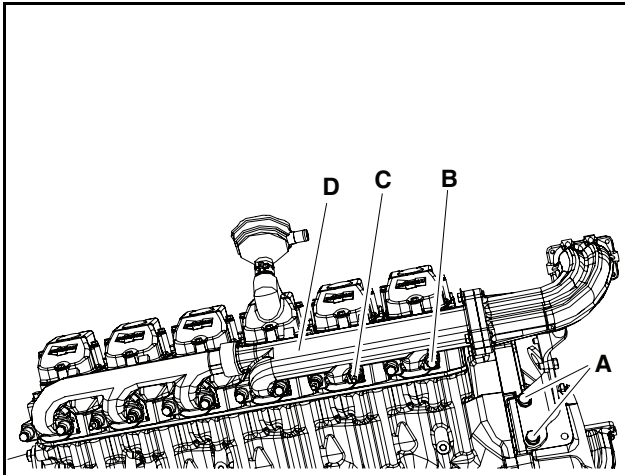

DV2213060A

- 1) Attach the exhaust manifold and exhaust elbow assembly(D).
- 2) Tighten 8 fixing bolts(B) and 4 fixing bolts(C) at a tightening torque $7.0\text{kgf}\cdot\text{m} \pm 1.05\text{kgf}\cdot\text{m}$.
- 3) Tighten the exhaust elbow bracket fixing bolts(A) at a tightening torque $20.0\text{kgf}\cdot\text{m} \pm 1.5\text{kgf}\cdot\text{m}$.
- 4) Attach the other exhaust manifold and exhaust elbow assembly as the same procedure.

Note) Tighten the fixing bolts to attach the exhaust manifold and the elbow bracket at a tightening torque $8.0\text{kgf}\cdot\text{m} \pm 0.5\text{kgf}\cdot\text{m}$

CAUTION

Be careful not to mix the fixing bolts.

42. Attach the turbocharger.

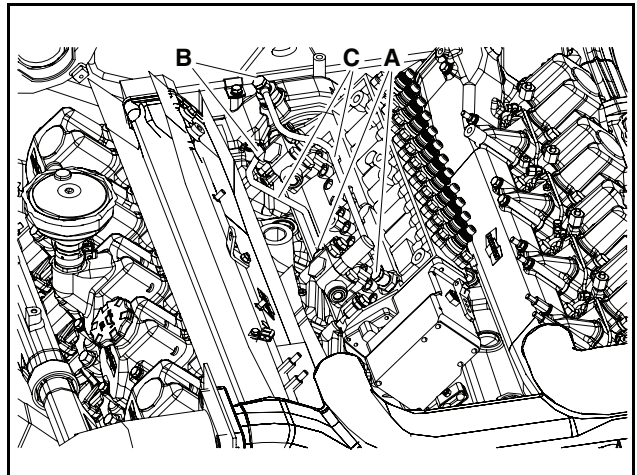

DV2213070A

- 1) Attach the turbocharger(B).
 - 2) Tighten 4 fixing bolts(A).
 - 3) Attach the other turbocharger as the same procedure.
43. Attach the oil return pipe.

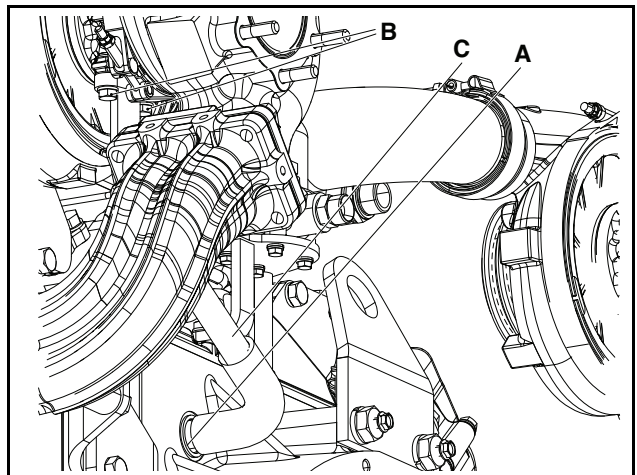

DV2213169A

- 1) Attach the oil return pipe(C).
- 2) Tighten 2 fixing bolts(B).
- 3) Tighten the clamp.
- 4) Attach the other turbocharger as the same procedure.

5. About the engine

44. Attach the oil delivery pipe.

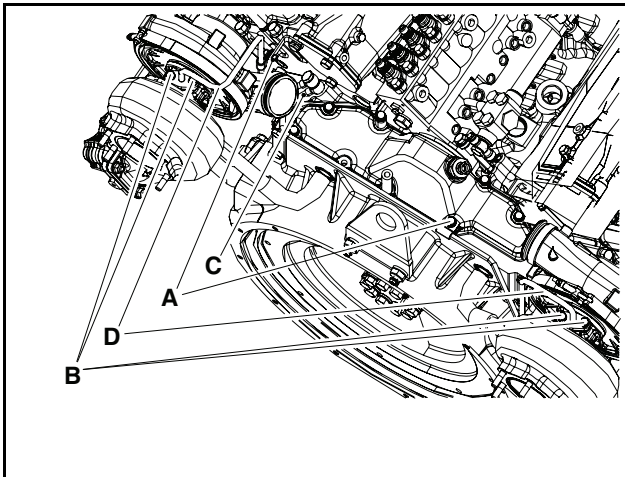

DV2213058A

- 1) Attach the oil delivery pipe(D).
- 2) Attach the hollow screw(C).
- 3) Tighten the oil delivery pipe fixing bolts(B) at a tightening torque $2.2\text{kgf}\cdot\text{m} \pm 0.33\text{kgf}\cdot\text{m}$.
- 4) Tighten the oil delivery pipe fixing bracket bolts(A) at a tightening torque $2.2\text{kgf}\cdot\text{m} \pm 0.33\text{kgf}\cdot\text{m}$.

⚠ CAUTION

Make sure that the O-rings and the gaskets have been attached.

45. Attach the inlet elbow.

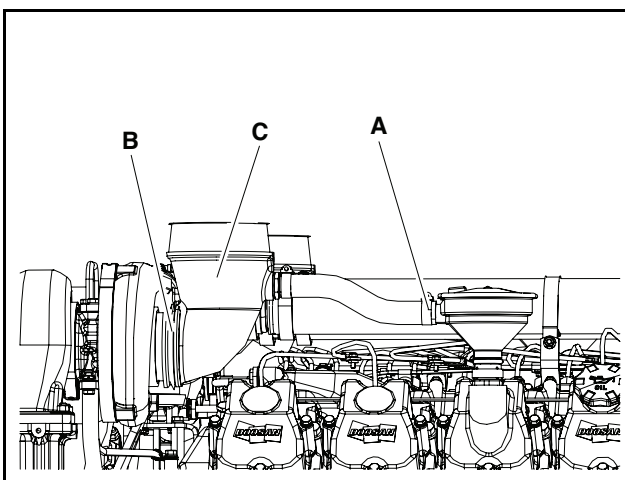

DV2213057A

- 1) Attach the inlet elbow(C).
- 2) Tighten the V-clamp(B).
- 3) Tighten the hose clamp(A).

4) Attach the other inlet elbow as the same procedure.

⚠ CAUTION

Make sure that the O-ring and the insert parts have been attached.

46. Attach the oil cooler housing.

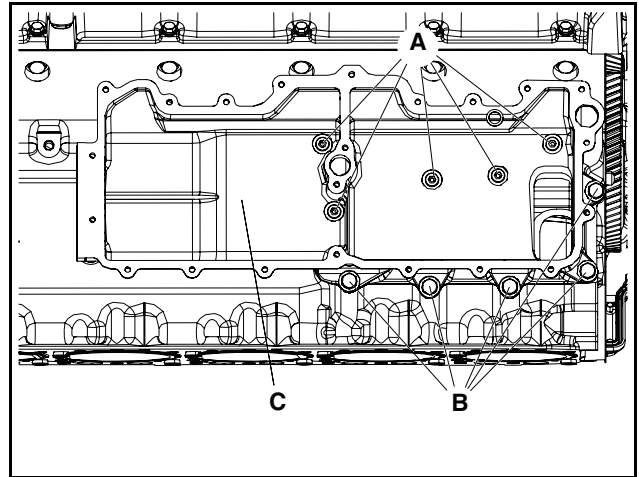

DV2213085A

- 1) Attach the oil cooler housing(C).
- 2) Tighten 5 M10 outer fixing bolts(B) at a tightening torque $6.2\text{kgf}\cdot\text{m}$.
- 3) Apply LOCTITE 262 on the M10 inner socket bolts(A).
- 4) Tighten 5 M10 inner socket bolts(A) at a tightening torque $6.2\text{kgf}\cdot\text{m}$.

47. Attach the cooling water pipe.

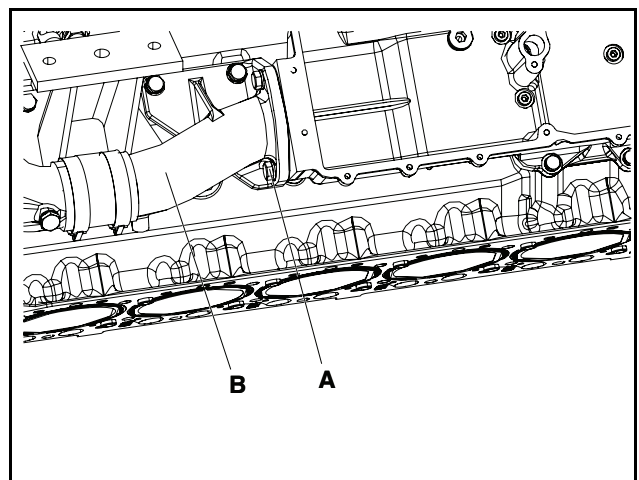

DV2213084A

- 1) Attach the cooling water pipe(B).
- 2) Tighten 4 fixing bolts(A) at a tightening torque $8.0\text{kgf}\cdot\text{m} \pm 1.2\text{kgf}\cdot\text{m}$.

5. About the engine

48. Attach the oil cooler cover.

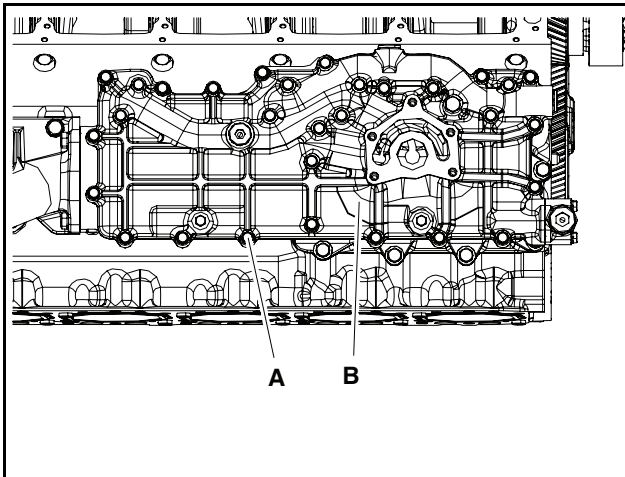

DV2213083A

- 1) Attach the oil cooler and the oil cooler cover(B).
- 2) Tighten 20 M8 fixing bolts(A) at a tightening torque 2.2kgf·m.

CAUTION

Make sure that the gaskets have been attached.

49. Attach the oil filter assembly.

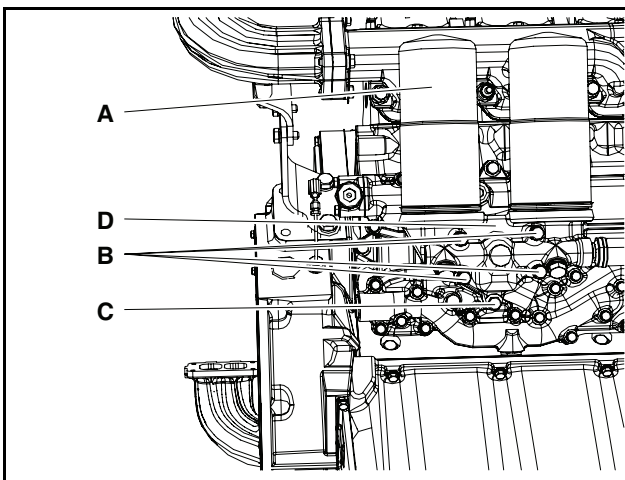

DV2213082A

- 1) Attach the oil filter housing(D).
- 2) Tighten the fixign bolts(B) and (C).
- 3) Attach the oil filter(A) with the chain plier(EF.200-038).

CAUTION

- Make sure that the gaskets have been attached.
- Be careful not to run down oil.

50. Attach the crankshaft pulley.

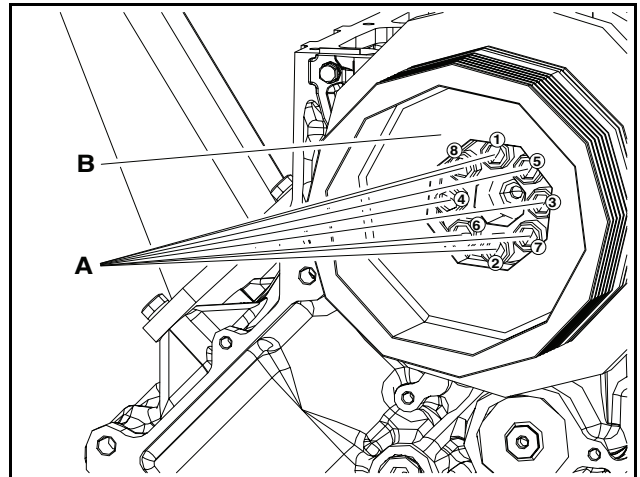

DV2213190A

- 1) Attach the crankshaft pulley(B).
- 2) Tighten 8 M16 stud head bolts(A) at a tightening torque 21.0kgf·m ±1.0kgf·m.

Note) Tighten the stud head bolts in the order from (1) ~ (8).

51. Attach the cooling fan pulley and the idle pulley.

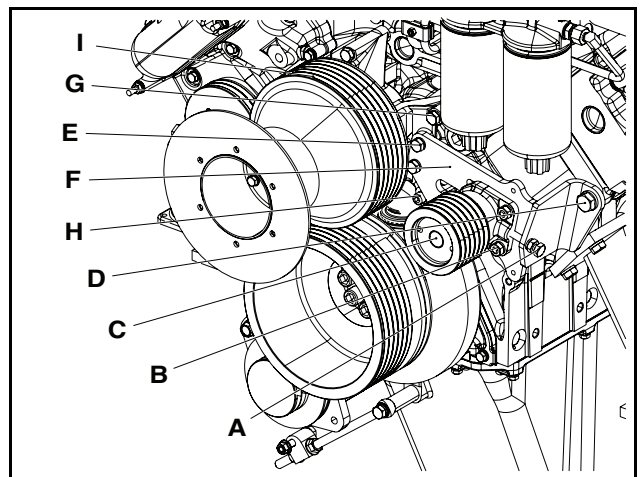

DV2213174A

- 1) Attach the cooling fan pulley assembly(I).
- 2) Tighten 3 fixing bolts(G) and 1 socket bolt(H) at a tightening torque 4.4kgf·m ± 0.33kgf·m.
- 3) Fix the cooling fan pulley using the jig.
- 4) Tighten 1 cooling fan fixing bolt at a tightening torque 20kgf·m.
- 5) Attach the idle pulley bracket(F).
- 6) Tighten 3 fixing bolts(G) and 1 socket bolt(H) at a tightening torque 4.4kgf·m ± 0.33kgf·m.
- 7) Tighten 1 fixing bolt(D).
- 8) Attach the idle pulley(C).

5. About the engine

9) Tighten 1 fixing bolt(A) and 2 fixing nuts(B).

⚠ CAUTION

Make sure that the cooling fan pulley can be rotated after attaching.

52. Attach the water pump.

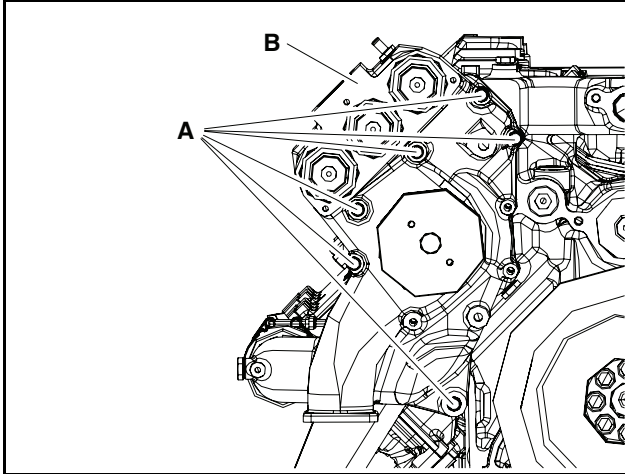

DV2213097A

- 1) Attach the water pump assembly(B).
- 2) Tighten 16 fixing bolts(A).

⚠ CAUTION

Be careful not to mix the fixing bolts each other.

53. Attach the thermostat.

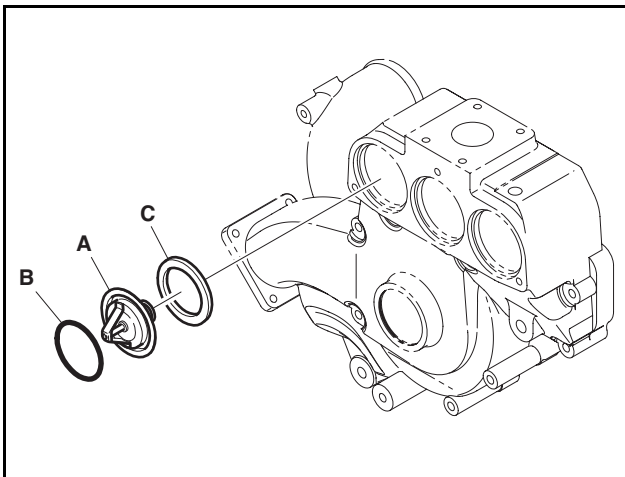

DV2213172A

- 1) Attach the gasket(C).
- 2) Attach the thermostat(A).
- 3) Attach the o-ring(B).
- 4) Attach 3 thermostats as the same procedure.

54. Attach the cooling water pipe.

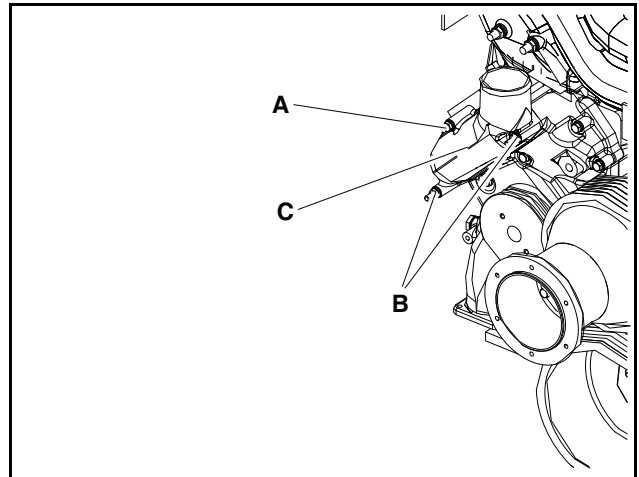

DV2213078A

- 1) Attach the cooling water pipe(C).
- 2) Tighten the fixing bolts(A) and nuts(B) at a tightening torque $2.2\text{kgf}\cdot\text{m} \pm 0.33\text{kgf}\cdot\text{m}$.

55. Attach the starter.

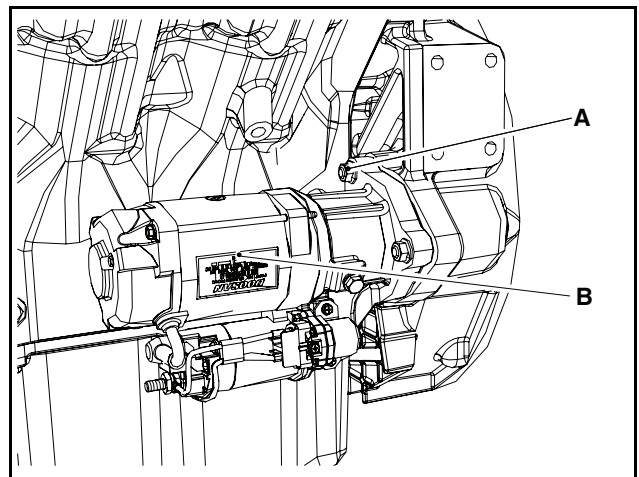

DV2213053A

- 1) Attach the starter(B).
- 2) Tighten 3 fixing bolts(A) at a tightening torque $4.4\text{kgf}\cdot\text{m} \pm 1.2\text{kgf}\cdot\text{m}$.

5. About the engine

56. Attach the alternator bracket.

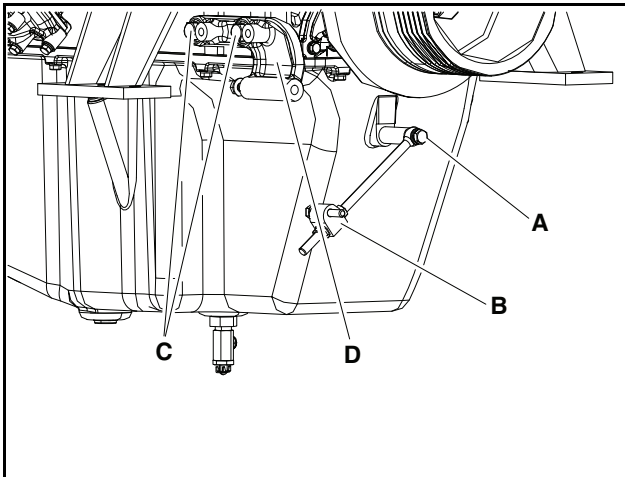

DV2213056A

- 1) Attach the alternator(D).
- 2) Tighten the fixing bolts(C) at a tightening torque $7.0\text{kgf}\cdot\text{m} \pm 0.5\text{kgf}\cdot\text{m}$.
- 3) Attach the eyebolt(B).
- 4) Tighten the fixing bolt(A) at a tightening torque $2.2\text{kgf}\cdot\text{m} \pm 0.33\text{kgf}\cdot\text{m}$.

57. Attach the alternator.

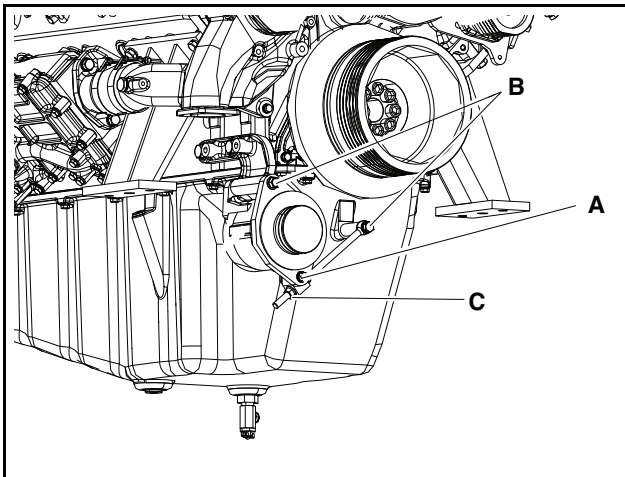

DV2213055A

- 1) Attach the alternator(C).
- 2) Tighten the fixing bolt(B).
- 3) Tighten the fixing nut(A) at a tightening torque $2.2\text{kgf}\cdot\text{m} \pm 0.33\text{kgf}\cdot\text{m}$.

58. Adjust the tension after attaching the V-belt.

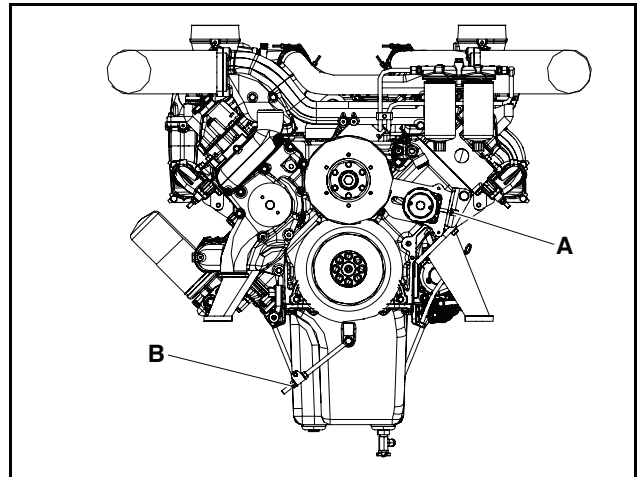

DV2213054A

- 1) Attach the V-belt and then adjust the tension with turning the adjusting nut(B).
- 2) Attach the V-belt and then adjust the tension with turning the adjusting nut(A).

59. Attach the cooling fan.

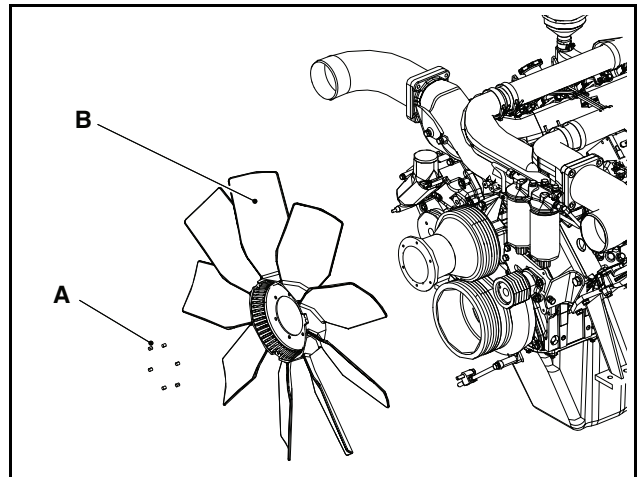

DV2213052A

- 1) Attach the cooling fan(B).
- 2) Tighten 6 fixing bolts(A).

60. Inject the coolant.

- 1) The mixing ratio for the engine coolant is 40% anti-freeze and 3~5% additives (DCA4) to prevent corrosion.
- 2) Add the coolant of the correct mixing ratio.

CAUTION

Use coolant recommended by Doosan.

5. About the engine

61. Add the engine oil.

- 1) Add our recommended genuine oil to replenish the oil level.

 **CAUTION**

Use genuine engine oil recommended by Doosan.

6. Cooling system

- General information 117
 - General Information 117
 - Specifications 117
 - Failure Diagnosis 120
- Thermostat 121
 - General Information 121
 - Check of the thermostat 121

6. Cooling system

General information

General Information

This engine is water-cooled. It uses coolant to cool the engine by absorbing heat from the combustion chamber and the engine oil and then releases the heat, allowing for normal engine operation.

In this cooling system, coolant provided by the coolant pump flows into the oil cooler through the coolant pipe to absorb oil heat and passes through the coolant jacket of the cylinder block and the cooling path of the cylinder head to absorb the combustion heat.

Coolant which absorbed the oil and combustion heat flows into the water temperature controller through the coolant pipe. If the coolant temperature is lower than the valve-opening temperature of the water temperature controller, the coolant flows into the coolant pump. If higher, it flows into the radiator. The radiator releases the heat absorbed from the coolant and sends the coolant to the coolant pump again.

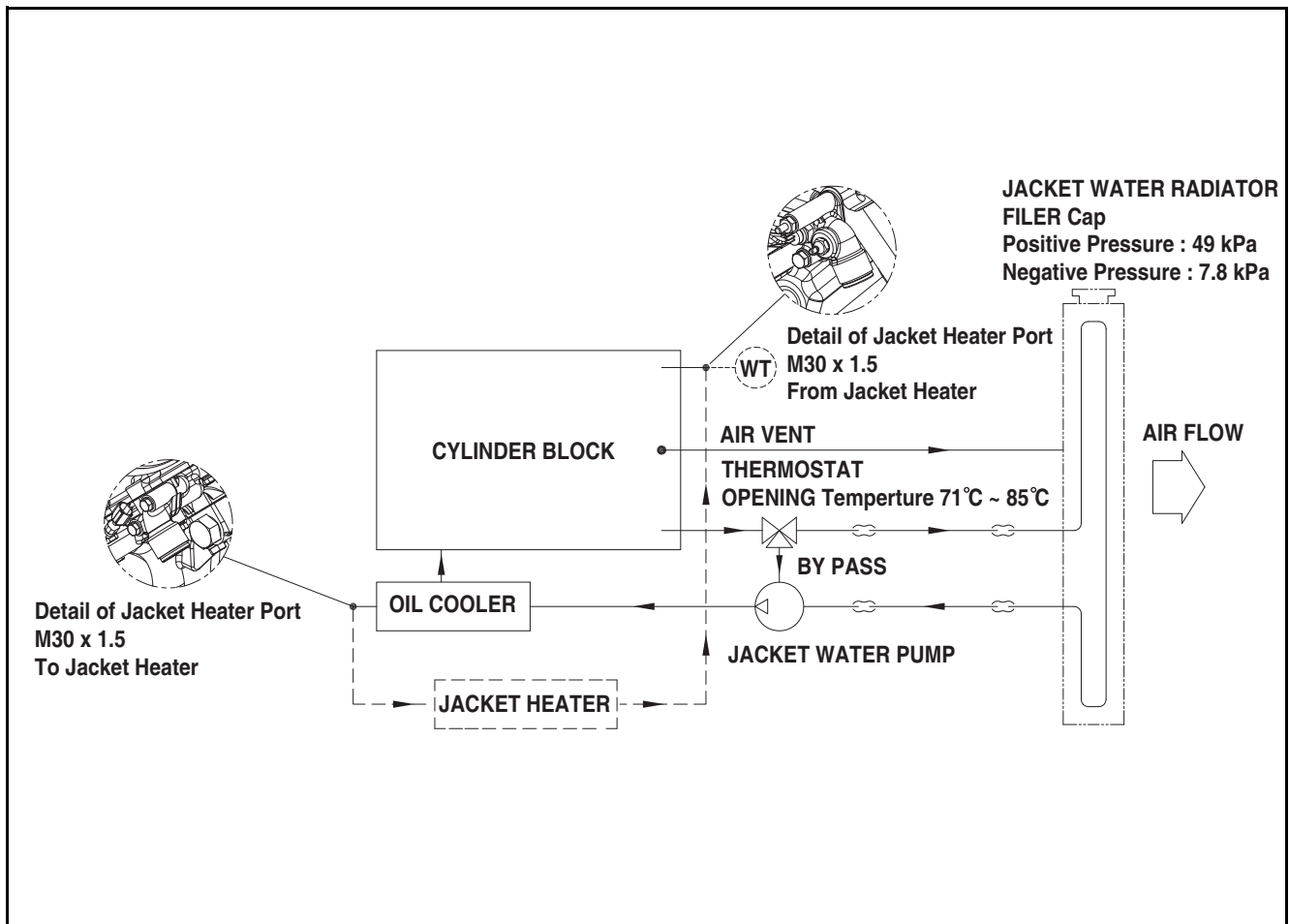

DV2213098A

Specifications

Item	DP158L				Remarks
	DP158LCS	DP158LCF	DP158LDS	DP158LDF10	
Cooling System					
Cooling method	Fresh water forced circulation				
Coolant capacity (L)	Engine only	Approx. 20			
	With radiator	Approx. 79 (Air on 43°C) / Approx 90 (Air on 52°C)			

6. Cooling system

Item		DP158L				Remarks
		DP158LCS	DP158LCF	DP158LDS	DP158LDF10	
Coolant flow rate (L /min)		660	550	660	550	
Pressure cap (kPa)		Max. 49				
Water temperature (°C)	Max. for stand by and prime	103				
	Before start of full load	40				
Water pump		Centrifugal type driven by belt				
Thermostat	Type	Wax-pellet type				
	Opening temp. (°C)	71				
	Full open temp. (°C)	85				
Cooling fan	Type	Blow Type				
	Diameter - blades	915mm - 7 blades				

Item		DP180L				Remarks
		DP180LBS	DP180LBF	DP180LAS	DP180LAF	
Cooling System						
Cooling method		Fresh water forced circulation				
Coolant capacity (L)	Engine only	Approx. 21				
	With radiator	Approx. 79 (Air on 43°C) / Approx 90 (Air on 52°C)				
Coolant flow rate (L /min)		660	550	660	550	
Pressure cap (kPa)		Max. 49				
Water temperature (°C)	Max. for stand by and prime	103				
	Before start of full load	40				
Water pump		Centrifugal type driven by belt				
Thermostat	Type	Wax-pellet type				
	Opening temp. (°C)	71				
	Full open temp. (°C)	85				
Cooling fan	Type	Blow Type				
	Diameter - blades	915mm - 7 blades				

6. Cooling system

Item	DP222L					Remarks
	DP222LAS	DP222LBS	DP222LBF	DP222LCS	DP222LCF	
Cooling System						
Cooling method		Fresh water forced circulation				
Coolant capacity (L)	Engine only	Approx. 23				
	With radiator	Approx. 114 (Air on 43°C) / Approx 125 (Air on 52°C)				
Coolant flow rate (L/min)		660	660	550	660	550
Pressure cap (kPa)		Max. 49				
Water temperature (°C)	Max. for stand by and prime	103				
	Before start of full load	40				
Water pump		Centrifugal type driven by belt				
Thermostat	Type	Wax-pellet type				
	Opening temp. (°C)	71				
	Full open temp. (°C)	85				
Cooling fan	Type	Blow Type				
	Diameter - blades	915mm - 9 blades				

6. Cooling system

Failure Diagnosis

Phenomenon	Causes	Troubleshooting
Overheated engine	Not enough coolant	Replenish the coolant
	Defective radiator cap	Replace it
	Contaminated radiator	Clean the exterior of the radiator
	Defective V-belt offset	Adjust or replace it
	Contaminated or damaged V-belt	Replace it
	Damaged impeller	Replace the coolant pump
	Defective impeller fix	Replace the coolant pump
	Bad coolant pump operation	Replace it
	Bad water temperature controller operation	Replace it
	Bad coolant flow	Clean the coolant path
	Improper injection time	Check it with the failure diagnosis unit
	Damaged cylinder head gasket	Replace it
Overcooled engine	Bad water temperature controller operation	Replace it
	Too low ambient temperature	Heat the block
Leaking coolant	Damaged radiator	Repair or replace it
	Loosened or damaged radiator connection	Repair or replace the connection
	Defective radiator cap	Replace it
	Badly mounted coolant pump	Repair or replace it
	Bad or damaged coolant pump gasket	Replace the gasket
	Badly mounted water temperature controller	Repair or replace it
	Bad or damaged water temperature controller gasket	Replace the gasket
	Damaged cylinder head gasket	Replace the gasket
	Damaged cylinder head or block	Replace it
Noise	Bad coolant pump bearing	Replace the bearing
	Bad or damaged cooling fan	Repair or replace it
	Bad rotation of the cooling fan	Replace it
	Defective V-belt offset	Adjust or replace it

Thermostat

General Information

The thermostat maintains water temperature in the engine consistently and prevents heat loss to improve heat efficiency of the engine.

When the coolant temperature is below the normal temperature, the thermostat is closed and the coolant is bypassed and directly flows into the water pump. When the coolant temperature reaches the normal temperature or is higher than the temperature, the thermostat is fully open and the bypass circuit is closed. So the coolant flows into the radiator.

CAUTION

- The wax pellet type thermostat shows slower response to the change of cooling water than the bellows type thermostat. This happens because the heat capacity of the wax pellet type water temperature controller is larger than that of the bellows type water temperature controller. Therefore, to prevent rapid increase of engine coolant temperature, you must first operate the engine at idle until the engine is fully warmed up. When the weather is very cold, do not operate the engine in an overloaded condition or at high speed after starting the engine.
- When draining water from the engine cooler or injecting water to the engine cooler, work slowly to let the air in the cooler is fully exhausted.
- When a defect is found in the water temperature controller, replace it with a new one.

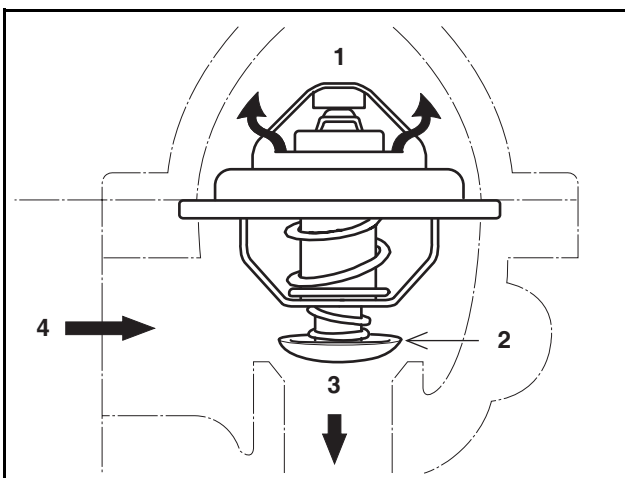

DV2213099A

- | | |
|-------------------|-----------------|
| 1. Heat exchanger | 3. Coolant pump |
| 2. Bypass valve | 4. Coolant pipe |

Check of the thermostat

1. Check whether the wax pellet and the spring are damaged or not.
2. Put the water temperature controller into water and heat the water slowly to check water temperature controller operation.
3. The water temperature controller is normal in the following case: it starts to be open at the water temperature of 82°C and it is fully open at the water temperature of 97°C.

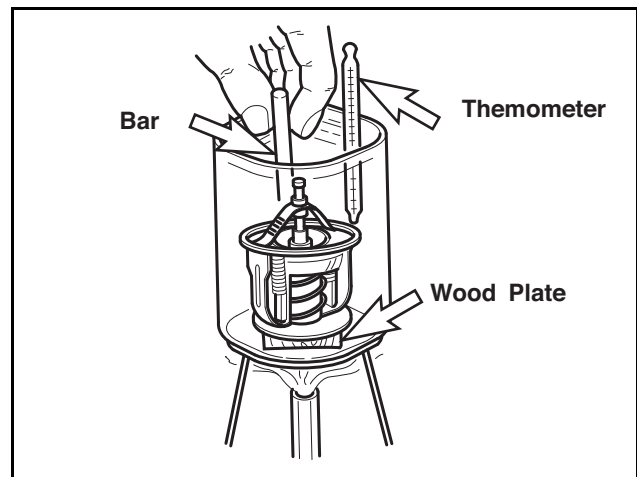

DV2213100A_E

4. Check if there is any foreign substance in the water temperature controller.
Note) Clean the inside of the water temperature controller with an air gun.
5. Check if there are any foreign substance or damage part inside and outside of the hose.

7. Lubrication system

- General information 125
 - General Information 125
 - Specifications 125
 - Failure Diagnosis 127

7. Lubrication system

General information

General Information

This engine is the forced lubrication type of engine. Oil pressure is generated and delivered by rotating the gear of the oil pump which is directly engaged with the crankshaft gear on the front of the cylinder block.

The oil pump delivers oil sucked from the oil pan with the suction pipe to the main path of the cylinder block through the oil cooler and oil filter.

From the cylinder block, oil is delivered to the crankshaft bearings, camshaft bearings, and rocker arm for lubrication.

In addition, the turbocharger is connected to the engine lubrication circuit. Around the cylinder block and the timing gear, lubricating oil is dispersed. Each cylinder has an oil injection nozzle for cooling the bottom of the piston. Engine oil is filtered through the oil filter and purified.

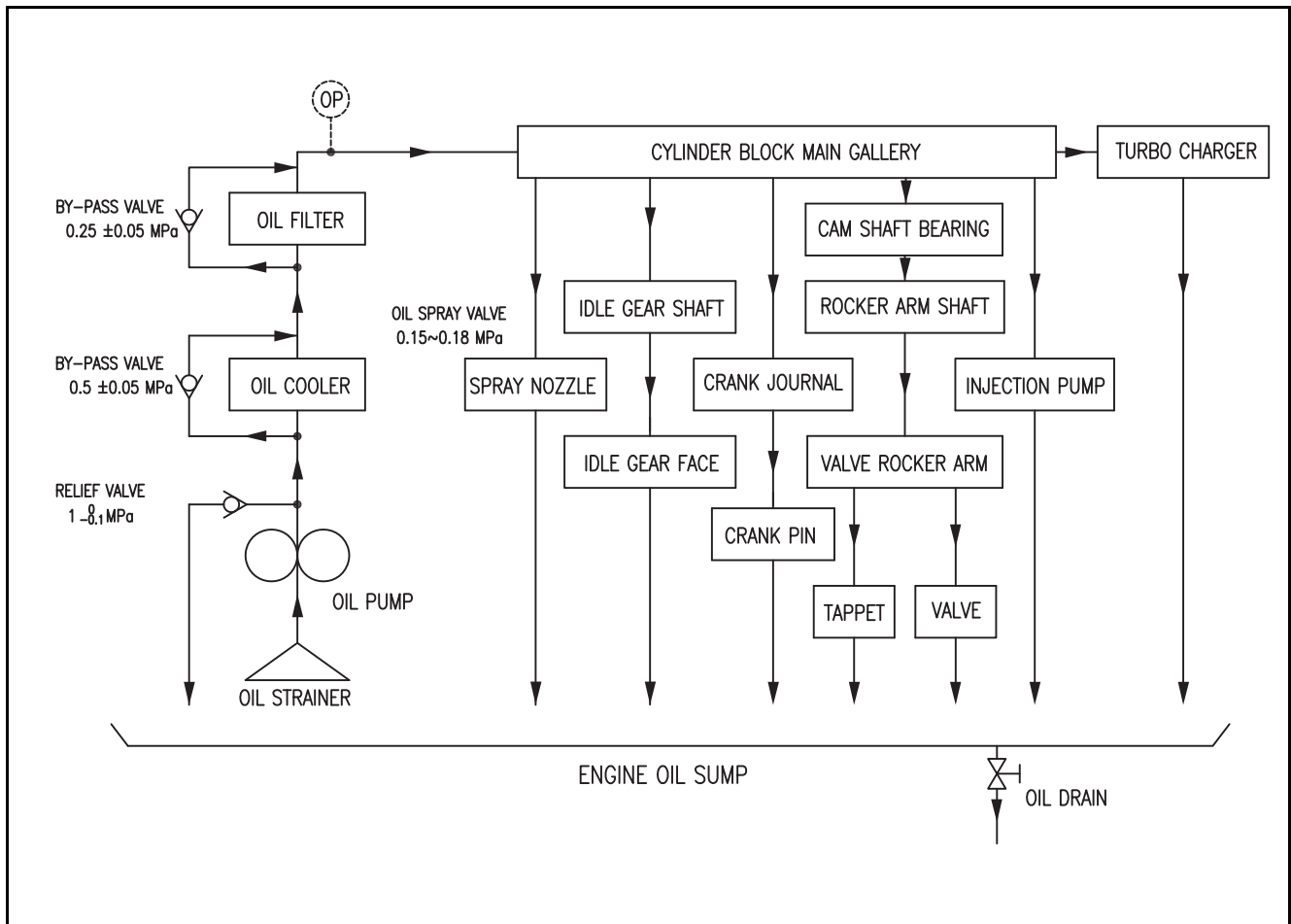

DV2213101A

Specifications

Item	DP158L				Remarks
	DP158LCS	DP158LCF	DP158LDS	DP158LDF10	
Lubrication System					
Lubrication method		Fully forced pressure feed type			
Oil pump	Type	Gear type			
	Driving type	Driven by crankshaft gear			
Oil filter		Full flow, Cartridge type			

7. Lubrication system

Item		DP158L				Remarks
		DP158LCS	DP158LCF	DP158LDS	DP158LDF10	
Oil capacity (L)	Max.	22				
	Min.	13				
Lubrication oil pressure (kPa)	Idle speed	Min. 100				
	Governed speed	Min. 250				
Max. oil temperature (°)		120				
Oil specification	Oil class	Above API CD				
	SAE	15W/40				

Item		DP180L				Remarks
		DP180LBS	DP180LBF	DP180LAS	DP180LAF	
Lubrication System						
Lubrication method		Fully forced pressure feed type				
Oil pump	Type	Gear type				
	Driving type	Driven by crankshaft gear				
Oil filter		Full flow, Cartridge type				
Oil capacity (L)	Max.	34				
	Min.	23				
Lubrication oil pressure (kPa)	Idle speed	Min. 100				
	Governed speed	Min. 250				
Max. oil temperature (°)		120				
Oil specification	Oil class	Above API CD				
	SAE	15W/40				

Item		DP222L					Remarks
		DP222LAS	DP222LBS	DP222LBF	DP222LCS	DP222LCF	
Lubrication System							
Lubrication method		Fully forced pressure feed type					
Oil pump	Type	Gear type					
	Driving type	Driven by crankshaft gear					
Oil filter		Full flow Cartridge type					
Oil capacity (L)	Max.	40					
	Min.	27					

7. Lubrication system

Item		DP222L					Remarks
		DP222LAS	DP222LBS	DP222LBF	DP222LCS	DP222LCF	
Lubrication oil pressure (kPa)	Idle speed	Min. 100					
	Governed speed	Min. 250					
Max. oil temperature (°C)		120					
Oil specification	Oil class	above API CD					
	SAE	15W/40					

Failure Diagnosis

Phenomenon	Causes	Troubleshooting
Too much oil consumption	Bad oil	Replace oil with specified oil.
	Oil leakage from the oil seal ring and packing part	Replace it
	Worn or damaged piston and piston ring	Replace it
	Worn cylinder liner	Replace it
	Burnt piston ring	Replace it
	Worn valve guide oil seal, valve guide, or valve stem	Replace it
Low oil pressure	Bad oil	Replace oil with specified oil.
	Burnt oil pump relief valve	Replace it
	Clogged oil pump strainer	Cleanse the strainer
	Worn oil pump gear	Replace it
	Cracked oil delivery pipe of the oil pump	Replace it
	Defect oil pump	Repair or replace it
	Oil pressure gauge fault	Repair or replace it
	Worn bearings	Replace it
Contaminated oil	Clogged oil filter	Replace the oil filter with a new one
	Gas leakage	Replace piston ring with a new one
	Bad oil	Replace oil with specified oil.

8. Fuel system

General information	131
General Information	131
High Sulfur content in diesel fuel	131
Water (Moisture) in diesel fuel	132
Specifications	132
Failure Diagnosis	133
Fuel injection pump	135
General Information	135
Actuator	136
Actuator Component Parts Function.	136
Controller system	138
DGC-2013 Governor Controller System	138
Description	138
Mounting & Warning.	138
EMC (Electromagnetic Compatibility)	139
Functions	139
Adjustments	139
External Wiring.	142
Magnetic speed sensor connections	143
Remote speed adjustment.	143
Droop parallel Operation mode (Manual paralleling)	144
Accessory Input (Automatic Paralleling)	144
Controller LAMP Display (diagnosis)	144
System Troubleshooting (Instability)	145
System inoperative	146
Adjustment Fuel Injection Pump	147

General information

General Information

The fuel is supplied by the fuel delivery pump through fuel filter to the fuel injection pump which delivers the fuel to the fuel injection nozzle.

The fuel is injected to the cylinder through the nozzle assembled to the fuel injection nozzle holder of the cylinder head.

Over-supplied fuel returns to the fuel tank through the return pipe.

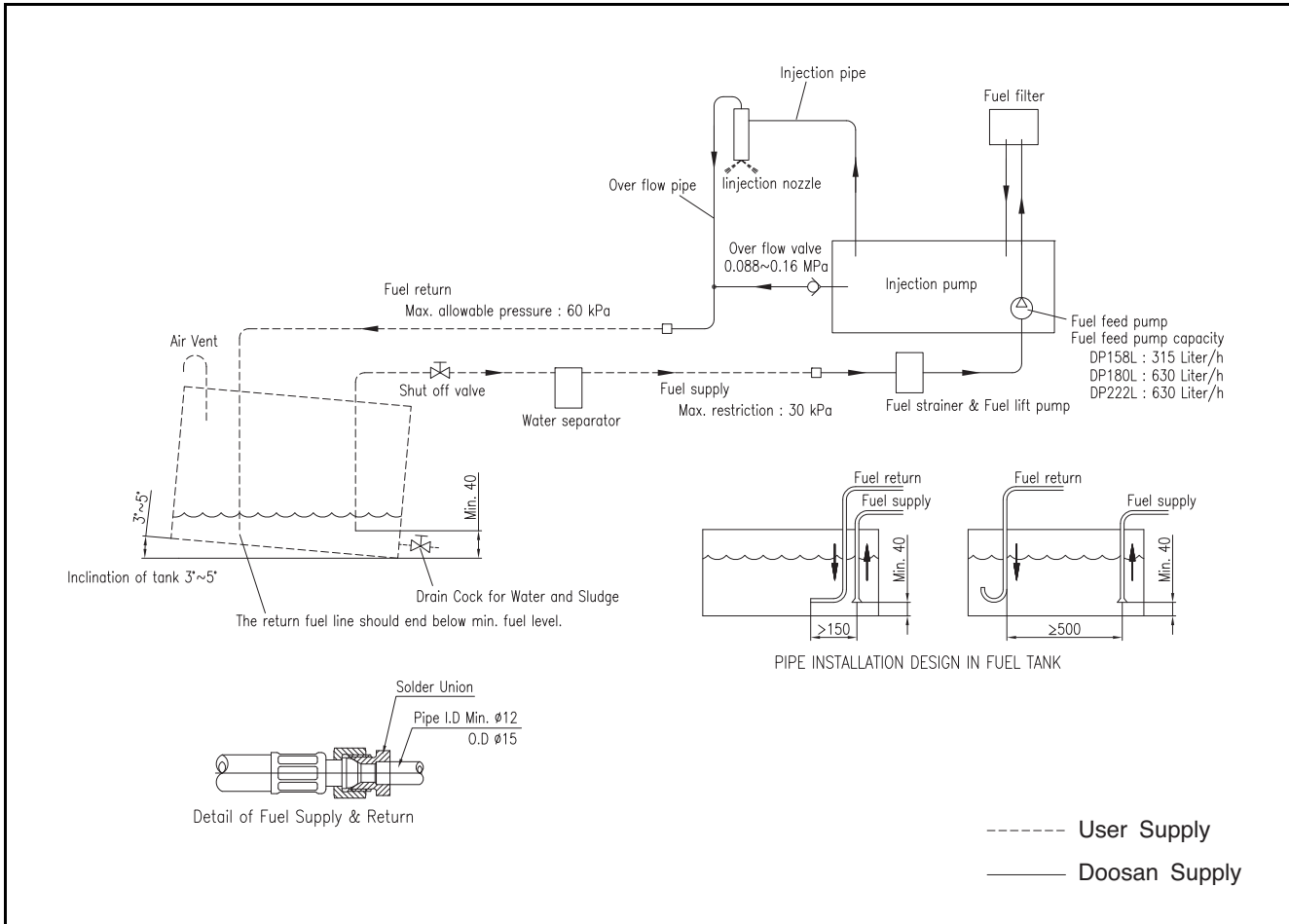

DV2213102B

The fuel lines should have a sufficient inner diameter. The fuel lines should be routed so that the fuel is not excessively heated by the heat radiation from the engine. The pipes should be laid as straight as possible without sharp bends. Make sure the pipes are protected against mechanical wear and well fastened to avoid vibrations. It is important that there are no fuel leakages or air infiltration neither on the suction or return line installation. Therefore securely fasten all the connections of fuel line. The return line back to the fuel tank must not be adjoin the suction line.

In case of diesel fuel containing high water content due to insufficient fuel quality, maintenance difficulty or environmental adversity, an extra water separator with adequate capacity must be installed as user supply scope.

High Sulfur content in diesel fuel

Doosan diesel engines can be operated with fuels Whose sulfur content is max. 0.05wt%.

Fuels with a sulfur content of $> 0.05\text{wt}\%$ are not Permitted as they result in increased corrosion and Hence greatly reduce the service life of the engines.

The oil and oil filter change intervals must be halved If the sulfur content is $> 0.02\text{wt}\%$.

8. Fuel system

Water (Moisture) in diesel fuel

Water in the fuel causes;

- Incomplete combustion
- lammed or clogged nozzle
- Damaged to the injection pump
- Piston damage

- Destruction of engine

In case of diesel fuel containing high water content due to insufficient fuel quality, maintenance difficulty or environmental adversity, an extra water separator with adequate capacity must be installed as user supply scope.

Specifications

Item	DP158L				Remarks
	DP158LCS	DP158LCF	DP158LDS	DP158LDF10	
Fuel System					
Injection pump		Bosch in-line "P" type			
Governor		Electric type			
Fuel feed pump	Type	Mechanical type injection pump			
	Capacity (L/hr)	315			
Injection nozzle	Type	Multi hole type			
	Opening pressure (MPa)	28			
Fuel filter		Full flow, Cartridge type with water drain valve			
Fuel Used		Diesel fuel oil			

Item	DP180L				Remarks
	DP180LBS	DP180LBF	DP180LAS	DP180LAF	
Fuel System					
Injection pump		Bosch in-line "P" type			
Governor		Electric type			
Fuel feed pump	Type	Mechanical type injection pump			
	Capacity (L/hr)	630			
Injection nozzle	Type	Multi-hole (4 hole)			
	Opening pressure (MPa)	28			
Fuel filter		Full flow, Cartridge type with water drain valve			
Fuel Used		Diesel fuel oil			

Item	DP222L					Remarks
	DP222LAS	DP222LBS	DP222LBF	DP222LCS	DP222LCF	
Fuel System						
Injection pump		Bosch in-line "P" type				

8. Fuel system

Item	DP222L					Remarks
	DP222LAS	DP222LBS	DP222LBF	DP222LCS	DP222LCF	
Governor	Electric type					
Fuel feed pump	Type	Mechanical type injection pump				
	Capacity (L/hr)	630				
Injection nozzle	Type	Multi hole type				
	Opening pressure (MPa)	28				
Fuel filter	Full flow, Cartridge type with water drain valve					
Fuel Used	Diesel fuel oil					

Failure Diagnosis

Symptom	Causes	Troubleshooting
1. Engine does not start A. Fuel is not supplied from the fuel delivery pump B. Fuel is not injected from the fuel injection pump C. Improper fuel injection timing D. Fuel injection nozzle not working	<ul style="list-style-type: none"> • Clogged fuel pipe, or air entered the fuel pipe line • Defective delivery pump valve • Seized delivery pump piston or push rod 	<ul style="list-style-type: none"> • Correct • Replace • Disassemble / correct
	<ul style="list-style-type: none"> • Clogged fuel filter cartridge • Air entered to the fuel filter or injection pump • Seizure or defect in the plunger or delivery valve 	<ul style="list-style-type: none"> • Clean / replace • Bleed • Disassemble / correct
	<ul style="list-style-type: none"> • Defective installation of fuel injection pump bracket • Defective adjustment of the fuel injection pump tappet • Excessively worn cam of camshaft 	<ul style="list-style-type: none"> • Inspect / correct • Inspect / correct • Replace
	<ul style="list-style-type: none"> • Seizure of needle valve of nozzle • Fuel leakage between nozzle and needle valve • Improper fuel injection pressure 	<ul style="list-style-type: none"> • Service or replace • Service or replace • Adjust
2. Engine starts but stops immediately	<ul style="list-style-type: none"> • Clogged fuel filter or clogged pipe between fuel delivery pump and injection pump • Air entered into fuel • Insufficient supply of oil by fuel delivery pump • Clogged air breather in fuel tank, causing insufficient fuel supply. 	<ul style="list-style-type: none"> • Clean or replace • Air bleeding • Disassemble / correct • Replace breather
3. Insufficient engine power	<ul style="list-style-type: none"> • Excessively work plunger • Improper injection timing • Defective delivery valve • Excessive fuel leakage in injection nozzle • Nozzle not working properly 	<ul style="list-style-type: none"> • Replace • Adjust • Replace • Service or replace • Disassemble / correct
4. Engine knocking occurs	<ul style="list-style-type: none"> • Early injection timing • High nozzle injection pressure • Nozzle not working properly 	<ul style="list-style-type: none"> • Adjust • Adjust • Disassemble / correct

8. Fuel system

Symptom	Causes	Troubleshooting
5. Excessive engine smoke and knocking	<ul style="list-style-type: none"> • Defective injection timing • Too low nozzle injection pressure • Broken nozzle spring • Nozzle not working properly • Excessively work plunger • Defective delivery valve seat • Excessive fuel supply 	<ul style="list-style-type: none"> • Adjust • Adjust • Replace it • Replace it • Adjust • Replace it • Check feed pump
6. Unstable engine power	<ul style="list-style-type: none"> • Insufficient fuel supply • Air entered into fuel • Water entered into fuel • Defective plunger operation • Defective actuator operation • Defective nozzle • Injection start pressure different between cylinders • Defective controller 	<ul style="list-style-type: none"> • Check feed pump • Air bleeding • Replace fuel • Disassemble / correct • Disassemble / correct • Disassemble / correct • Adjust • Adjust
7. Engine cannot reach the max. speed	<ul style="list-style-type: none"> • Nozzle not working properly • Defective operation of actuator or controller 	<ul style="list-style-type: none"> • Disassemble / correct • Adjust
8. Unstable engine idling	<ul style="list-style-type: none"> • Defective controller operation • Defective plunger operation • Defective magnetic pickup sensor 	<ul style="list-style-type: none"> • Adjust • Disassemble / correct • Inspect or replace

Fuel injection pump

General Information

The fuel injection pump is driven by the crankshaft gear. It is connected to the forced lubrication system, so separate connection is not required.

The governor of electric fuel injection pump is consist of the actuator that is operated by the signal of the control system and the control system that maintain the engine RPM as the changing load.

8. Fuel system

Actuator

Actuator Component Parts Function

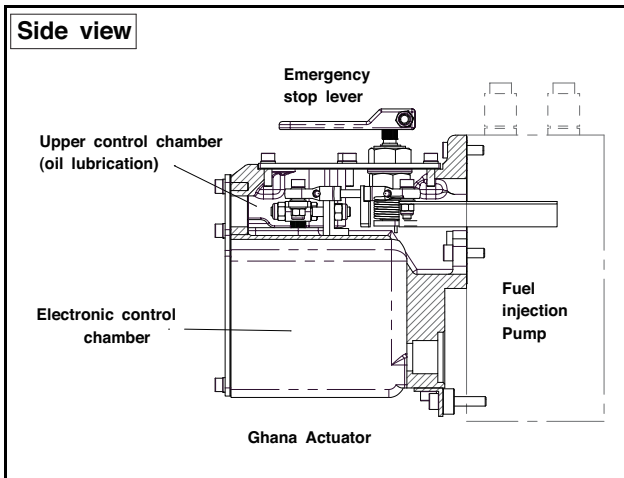

DV2213103B

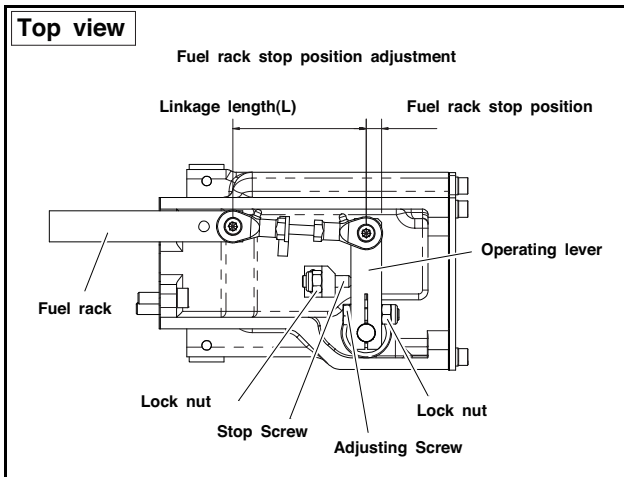

DV2213104B

1. Emergency stop lever: The manual engine stop lever when emergency.
2. Upper control chamber: The cover is install for inside control.
3. Electronic control chamber: The electronic signal operates the operation lever. It is sealed and can not control.
4. Adjusting screw: Adjusting screw is the controlled max. fuel capacity. If the length of the nut is long, the torque is decrease. if the the length of the nut is short, the torque is increase.
5. Fuel stop plate: The plate controls the increasing fuel as the preventing movement of adjusting screw.
6. Operation lever: It is the connecting lever to operate the fuel rack.

7. Fuel rack: It controls the fuel capacity of the fuel injection pump connected link lever.

CAUTION

Adjusting fuel injection pump is critical part for the engine performance and durability. Only certified professional technicians should repair and maintain engines.

8. Fuel system

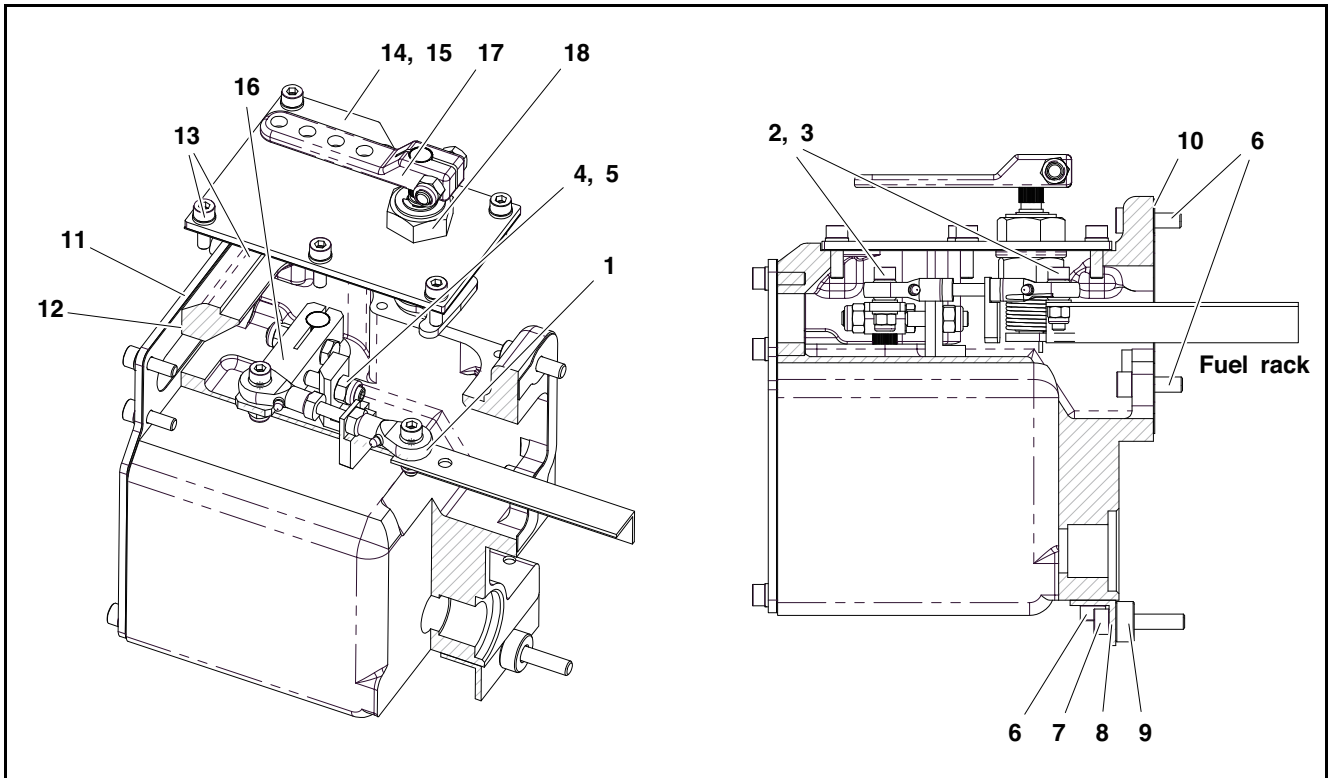

DV2213210

No	Title	Amount	Remarks
1	Ball link ASS'Y	1	M5xL15
2	Screw, Ball link	2	M5xL15
3	Plain Washer	2	ϕ 5.5x ϕ 14xT1.2
4	Stop Screw	1	M6xL25
5	Lock Nut	1	M6xP1.0
6	Allen Screw (SEMS)	6	M6x22L
7	Allen Screw (SEMS)	2	M6x30L or 18L
8	Mounting Bar	1	
9	Spacer	2	ϕ 6.5x ϕ 16xT7.4
10	Pump Gasket	1	T 0.5
11	Front Cover	1	T 3.2
12	Front Gasket	1	T0.5
13	Allen Screw	8	
	Seal Screw	4	
14	Top Cover	1	T 3.2
15	Top Gasket	1	T 0.5

No	Title	Amount	Remarks
16	Operating Lever	1	
17	Stop Lever	1	
18	Manual Stop Device ASS'Y	1	

8. Fuel system

Controller system

DGC-2013 Governor Controller System

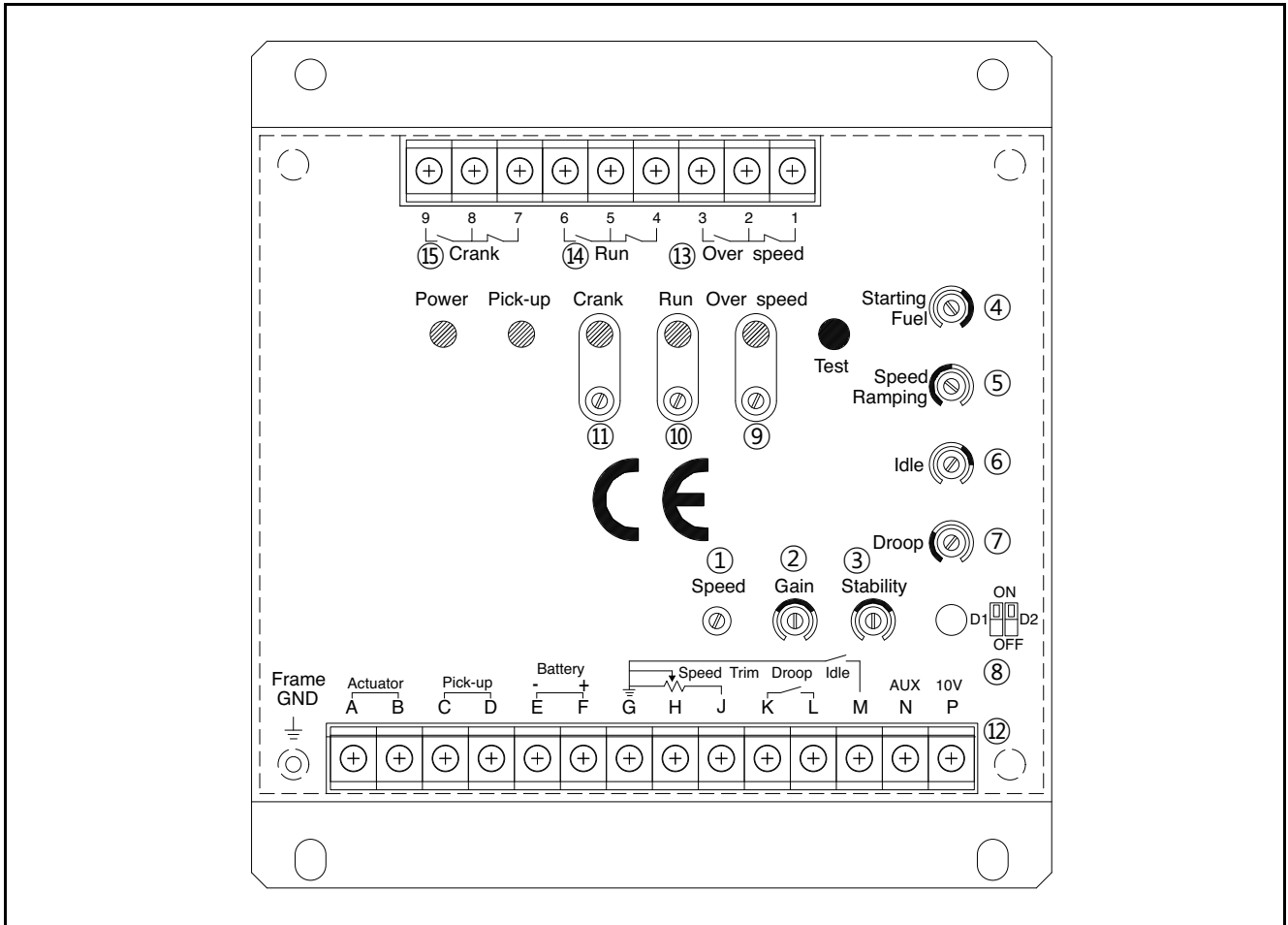

DV2213203B

Description

DGC-2013 Governor Controller Unit is an electronic device designed based on PID algorithm to control engine speed with fast and precise response to transient load changes. The device is available for both single operation (Isochronous mode) and parallel operation (Droop mode).

Mounting & Warning

DGC-2013 Governor Controller Unit is an electronic device designed based on PID algorithm to control engine speed with fast and precise response to transient load changes. The device is available for both single operation (Isochronous mode) and parallel operation (Droop mode).

1. Mount the controller unit vertically to the surface of a control cabinet, protected from the weather and high humidity, and do not expose the controller unit to the source of radiant heat. Prolonged exposure to moisture (for one month or longer or in case condensation forms) can lead to change in the resistance of internal circuit and failure to reach rated torque. Therefore, make sure that the controller is dry before use.
2. Do not rely exclusively on the governor system electric actuator to prevent overspeed. A secondary shutoff device, such as a fuel solenoid must be used.
3. The setting range indicated on each menu of the control mode is the average range for each engine. It is recommended to set DI engines within each indicated setting range.

EMC (Electromagnetic Compatibility)

To satisfy EMC requirements, the controller unit should be mounted on the grounded metal side, and it is required to use shielded wires for all signal lines and ground all the shields to one of the bolts used to mount the controller.

No product with EMC-related quality issues arising from not following the above instruction will be guaranteed.

Functions

1. (1) Speed: Adjusting the engine speed
2. (2) Gain: Adjusting the gain (governing sensitivity)
3. (3) Stability: Adjusting the stability (governing response)
4. (4) Starting Fuel: Adjusting the fuel amount at engine start up
5. (5) Speed Ramping: Adjusting the time to reach the rated speed
6. (6) Idle: Adjusting the idle speed
7. (7) Droop: Adjusting the percentage (%) of droop
8. (8) Dip Switch: Adjusting the dip switch
9. (9) Over Speed: Adjusting the point when overspeed lamp is on and the relevant relay is activated
10. (10) Run Lamp: Adjusting the point when run lamp is on and the relevant relay is activated
11. (11) Crank Lamp: Adjusting the point when crank lamp is on and the relevant relay is activated
12. (12) TB1: Terminal block for input and output
13. (13) TB2: Relay terminal for overspeed mode (capacity - 2A/125VAC).
14. (14) TB3: Relay terminal for run mode (capacity - 2A/125VAC).
15. (15) TB4: Relay terminal for crank mode (capacity - 2A/125VAC).

Adjustments

1. The ranges of resistance indicated on the case are applicable only to DI engines.
2. For potentiometer adjustment, use a small sized (-) screw driver. (Be cautious of potentiometers being damaged)

3. Check that all electrical connections are correctly made and terminal screws tightened.

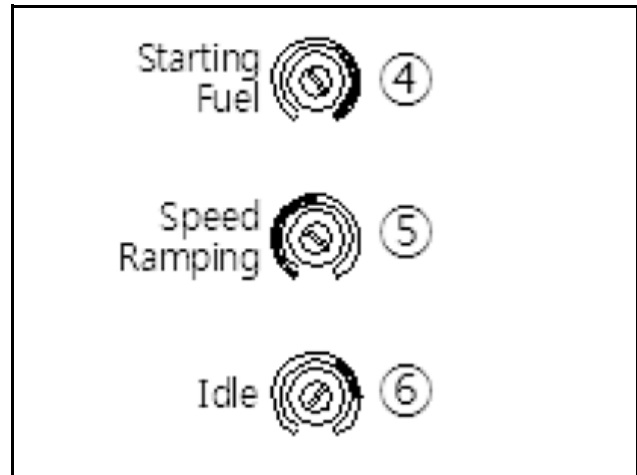

DV2213193B

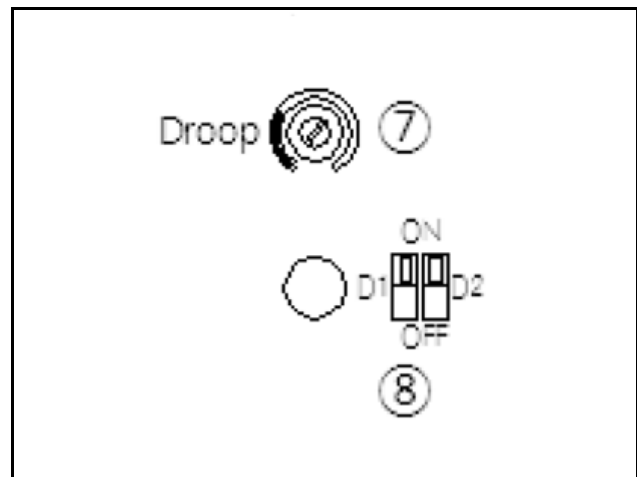

DV2213193C

4. Engine Startup

Connect terminals G and M (with idle switch ON).

- 1) (4) Starting Fuel

Note) Reason for adjustment: To maximize the fuel efficiency of the engine

* Purpose of adjustment:

Note) Recommended position: Between the 1 and 5 o'clock positions

Note) Possible problems: Between the 7 and 1 o'clock positions → starting problems due to a lack of fuel supply; The 5 o'clock position or above → decreasing fuel efficiency and increasing exhaust emissions at engine start up

- 2) Turn (5) Speed Ramping to between the 9 and 12 o'clock position.

Note) The time to reach the rated speed (run speed) prolongs as turning (5) Speed Ramping clockwise (max. over 10 sec)

8. Fuel system

Note) With (5) Speed Ramping biased to counterclockwise direction, a symptom of overshoot or hunting can occur.

3) Start cranking the engine.

5. Rated speed & Idle speed

1) Rated speed adjustment.

Note) After engine startup, remove the connection between terminals G and M (with idle switch OFF)

Note) Under no load condition, adjust Speed. Clockwise: RPM increase/counterclockwise RPM decrease

2) Idle speed adjustment

Note) With idle switch ON again, set the engine speed at 800 rpm by (6) Idle potentiometer.

Note) Reason for adjustment: To adjust pre-heat levels after engine start up or the initial fuel amount at engine start up

Note) Recommended position: Between the 12 and 3 o'clock positions. Though varying by engine model or rated RPM, it is recommended to set the RPM as 800RPM.

Note) Possible problems: Decreasing cold start performance and the excessive use of fuel during the warm-up phase.

CAUTION

Idle speed is one of the important factors to determine the characteristics of engine startup. Therefore, it is necessary to adjust the idle speed after rated speed adjustment regardless of the use of "idle mode."

6. Governor performance adjustment

1) Remove the connection between terminals G and M (with idle switch OFF). Once the engine reaches run speed, adjust the performance of governor.

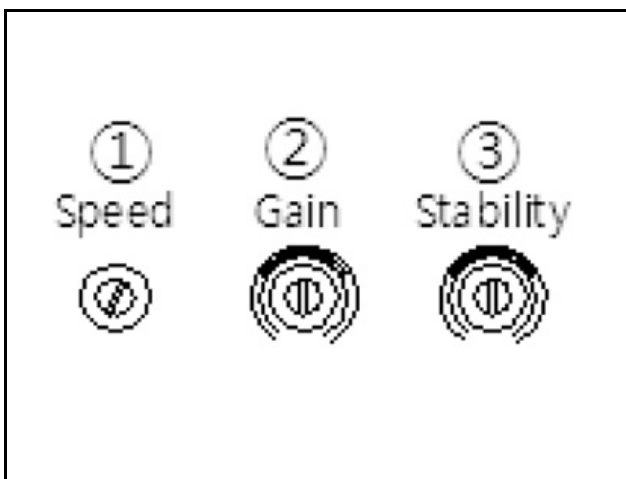

DV2213196B

2) Gain adjustment.

Note) Turn (2) Gain clockwise until instability develops at no load.

Note) Gradually move (2) Gain counterclockwise until stability returns.

Note) Move (2) Gain counterclockwise further by around 20 minutes (10°) to ensure stable performance.

3) Stability adjustment.

Note) Turn (3) Stability clockwise at no load until instability develops.

Note) Gradually move (3) Stability counterclockwise until stability returns.

Note) Move (3) Stability counterclockwise further by around 20 minutes (10°) to ensure stable performance.

7. Accessory adjustment

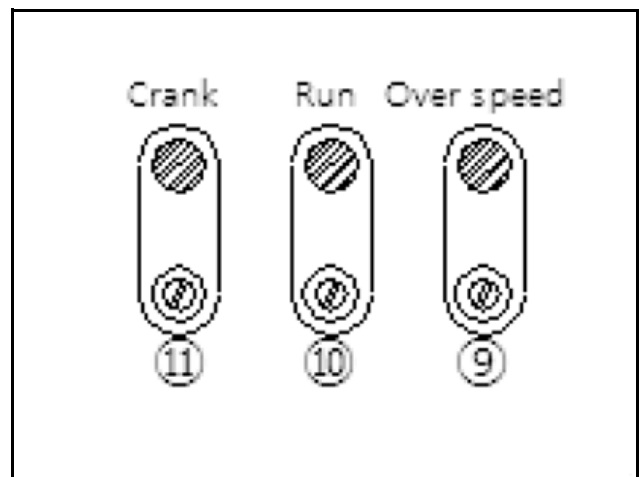

DV2213196C

1) Run Lamp ON

Note) At the rated speed, turn (10) Run counterclockwise until the Run Lamp is on.

Note) Move (10) Run counterclockwise further by 90° to prevent the Run Lamp from flickering.

2) Crank Lamp ON

Note) At the idle speed, turn (10) Crank counterclockwise until the Crank Lamp is on.

Note) Move (10) Crank counterclockwise further by 90° to prevent the Crank Lamp from flickering.

3) Overspeed Lamp ON

Note) At the rated speed, as pressing the Test button, gradually turn (9) Over Speed counterclockwise until the Overspeed Lamp is on and the engine is shut off simultaneously.

Note) With the adjustment above, the overspeed function is triggered at around 115% of the rated speed.

CAUTION

On completion of all the adjustments, start up the engine again to ensure the stable operation at engine startup, at no load, and at load operation, respectively.

8. Starting Fuel Adjustment (to minimize the engine's exhaust smoke)
 - 1) Turn on idle speed switch → Set the idlespeed at 800RPM → Turn (4) Starting Fuel counterclockwise until the engine speed begins to fall → Move (4) Starting Fuel clockwise further by 15° to stabilize the engine speed.
-

CAUTION

In case the exhaust smoke is not thick, It is recommended to place (4) Starting Fuel at the 5 o'clock position. If (4) Starting Fuel is set too low, It may be hard to start the engine and cause the speed overshoot on engine startup, even resulting in exceeding the preset overspeed value.

9. When the engine won't start
 - 1) If there is no wrong wiring → Return all adjustments to the "factory-set values" → Start up the engine again.

8. Fuel system

External Wiring

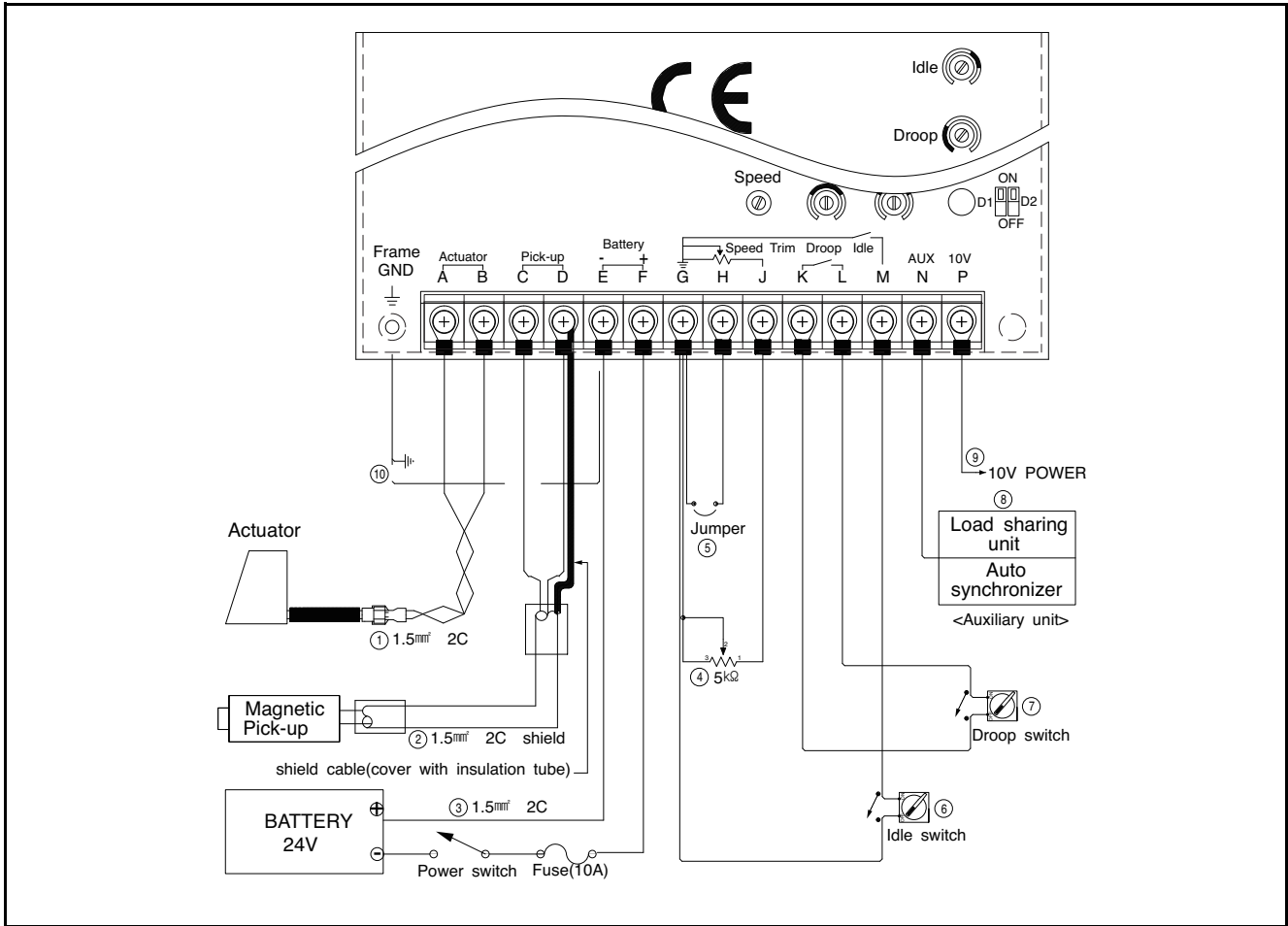

DV2213211A

- Wiring to the speed control unit should be as shown in DV2213211A.
 - All the cables should be 1.5mm² or larger and shielded cables should be used for all external connections.
 - Other shielded cables not described in DV2213211A should be grounded to the frame.
1. Twisted cables should be used for actuator connections. The normal reading of resistance between terminals A & B should be between 3.5Ω and 4.5Ω.
 2. Magnetic speed sensor connections to terminals C and D must be shielded for their entire length. The speed sensor cable should only be connected to terminal D. The shield should be insulated to ensure no other part of the shield comes in contact with engine ground. Otherwise, stray speed signals may be introduced to the speed control unit resulting in instability, etc.
 3. Be cautious that the battery's polarity to terminals E and F should not be switched and a 10 amp fuse must be installed between battery (+) and terminal F. After the wiring work, check the voltage between terminals which should be 24VDC (±4V). Ground the terminal E to the frame (wiring (10)).
 4. As illustrated in DV2213211A, connecting the optional 5kΩ resistance enables fine adjustment of engine speed within the range of preset speed ±210Hz range.
 5. In case of 12V system, or of actuator with current consumption over 5 amp or above, connect terminals G and H.
 6. Selector switch, switching over "IDLE mode" and "RUN mode" ON (close): idle mode OFF (open): run rated mode
 7. "DROOP" mode selector switch ON (close): DROOP mode OFF (open): Isochronous mode
 8. The signal from Auxiliary device for parallel operation system should be connected to terminal N. It is necessary to use the shielded cable for the signal.

9. Accessory power supply: The +10[V] and 20[mA] of current supply, Terminal P, can be utilized to provide power to governor system accessory and for various other purposes

⚠ CAUTION

Wrong or erroneous wiring and battery voltage can cause fatal damage to the controller.

Magnetic speed sensor connections

1. With the engine stopped, adjust the gap between the magnetic speed sensor and the ring gear teeth. The gap should not be any smaller than 0.45mm. Usually, backing out the speed sensor by 3/4 turn after touching the ring gear teeth will achieve a satisfactory air gap.
2. The signal from the speed sensor can be measured between C and D in engine operation.
3. Signal VAC 3 or above is required for the controller.

Remote speed adjustment

1. As illustrated in DV2213106A, a remote speed adjustment potentiometer can be used to adjust the engine speed over specific speed range. Select the desired speed range and the corresponding potentiometer value. When the minimum speed setting is used in remote adjustment mode, the speed drop phenomenon may occur due to instability and load in the system. To maintain engine stability at the minimum speed setting above, a small amount of droop can be added by turning (7) Droop counterclockwise. On the other hand, at the maximum speed setting, the governor performance will be near Isochronous regardless of the droop adjustment setting

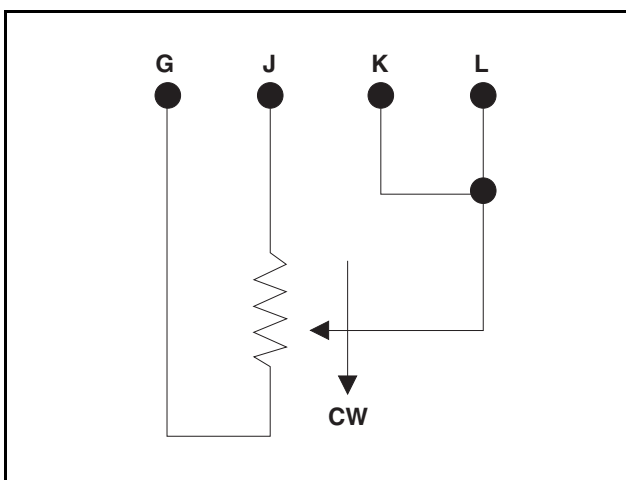

DV2213106A

Potentiometer Value by Speed Range

Speed range	Pote tiometer value	Engine RPM for Each Ring Gear		
		160 teeth	152 teeth	146 teeth
900Hz	1K	337rpm	355rpm	370rpm
2,400Hz	5K	900rpm	947rpm	986rpm
3,000Hz	10K	1,125rpm	1,184rpm	1,230rpm
3,500Hz	25K	1,315rpm	1,381rpm	1,438rpm
3,700Hz	50K	1,387rpm	1,460rpm	1,520rpm

Factory-set Value

300611-00683	
Overspeed	1,725rpm (No. of teeth = 160)
Run lamp	Maximum CW
Gain	Mid-range (12 O'clock)
Stability	Mid-range (12 O'clock)
Starting Fuel	Full CW ^a (Maximum Fuel)
Speed Ramping	9 O'clock
Droop	Full CCW ^b (Minimum)
Adjustment	(No. of teeth = 160)
Speed Adjustment	4,000Hz (1500rpm)
Idle Adjustment	2,133Hz (800rpm)

a. CW: Clockwise

b. CCW: Counterclockwise

300611-00684	
Overspeed	2,070rpm (No. of teeth = 160)
Run lamp	Maximum CW
Gain	Mid-range (12 O'clock)
Stability	Mid-range (12 O'clock)
Starting Fuel	Full CW ^a (Maximum Fuel)
Speed Ramping	9 O'clock
Droop	Full CCW ^b (Minimum)
Adjustment	(No. of teeth = 160)

8. Fuel system

300611-00684	
Speed Adjustment	4,800Hz (1800rpm)
Idle Adjustment	2,133Hz (800rpm)

- a. CW: Clockwise
b. CCW: Counterclockwise

300611-00685	
Overspeed	1,725rpm (No. of teeth = 152)
Run lamp	Maximum CW
Gain	Mid-range (12 O'clock)
Stability	Mid-range (12 O'clock)
Starting Fuel	Full CW ^a (Maximum Fuel)
Speed Ramping	9 O'clock
Drop	Full CCW ^b (Minimum)
Adjustment	(No. of teeth = 160)
Speed Adjustment	3,800Hz (1500rpm)
Idle Adjustment	2,026Hz (800rpm)

- a. CW: Clockwise
b. CCW: Counterclockwise

300611-00686	
Overspeed	2,070rpm (No. of teeth = 152)
Run lamp	Maximum CW
Gain	Mid-range (12 O'clock)
Stability	Mid-range (12 O'clock)
Starting Fuel	Full CW ^a (Maximum Fuel)
Speed Ramping	9 O'clock
Drop	Full CCW ^b (Minimum)
Adjustment	(No. of teeth = 160)
Speed Adjustment	4,053Hz (1800rpm)
Idle Adjustment	2,026Hz (800rpm)

- a. CW: Clockwise
b. CCW: Counterclockwise

Drop parallel Operation mode (Manual paralleling)

- Definition: Engine speed on the decrease against Engine load on the increase.

$$\text{DROOP}(\%) = \{(\text{No Load Speed} - \text{Full Load Rated Speed}) \times 100\} / \text{Full Load Rated Speed}$$

- Description: Droop is typically used for the load sharing and paralleling of engine driven generators. Without the Droop mode in paralleling system, generators can be overloaded or motorized.
- Application: For DROOP Operation,
 1. Close Droop selector switch between terminals K and L.
 2. When in Droop operation, the engine speed will decrease as engine load increase. The percentage of droop governing can be varied with (7) Droop potentiometer. The higher level of droop is achieved as turning (7) Droop clockwise.
- Droop level requirements above 10% are unusual and the minimum droop level to keep the stability of speed droop governor is 2.5% or above.
- After the droop level has been adjusted, the rated engine speed setting may need to be reset. Check the engine speed and adjust the speed setting accordingly.

Accessory Input (Automatic Paralleling)

- The Auxiliary terminal N accepts input signals from load sharing units, auto synchronizers, and other governor system accessories.
- It is recommended that this connection from accessories be shielded as it is a sensitive input terminal.
- When an accessory is connected to Terminal N, the speed will decrease and the speed adjustment must be reset.
- When operating in the upper end of the control system frequency range, a jumper wire or frequency trim control may be required between Terminals G and J. This increases the frequency range of the speed control to over 7,000Hz.

Controller LAMP Display (diagnosis)

- Power : When the battery power is connected and inner control power (DC 12V) is achieved, the lamp is on and main controller is ready to function.
- Pick Up : When the voltage between terminals C and D is VAC 3.0 or above, the lamp is on.
- Crank : When the engine reaches the preset rated speed (idle speed), the lamp is on and relevant relay is achieved.
- Run : When the engine reaches the preset rated speed (operating speed), the lamp is on and relevant relay is achieved.

- Over Speed : When the engine reaches the preset overspeed, the lamp is on and relevant relay is activated and the power to the actuator is shut off.

System Troubleshooting (Instability)

1. Fast instability (Hunting)
 - 1) When the position of switch D1 is ON, the differential function is activated.
 2. It provides fast transient response against engine speed changes.
 3. However, it may generate fast instability being sensitive to external high frequency noise. In this case, place the switch D1 to OFF position and readjust (2) Gain and (3) Stability.
 4. If instability should be still present, placing D2 to OFF position may help stabilize the engine. Again, readjust (2) Gain and (3) Stability for optimum control.
5. Slow instability (Hunting)

Slow instability can have many causes, most of which are due to wrong setting against the engine characteristics. Adjustment of (2) Gain and (3) Stability usually cures most situations
6. If the troubleshooting above is not successful
 - 1) Due to the controller at fault - Replace the controller with new one.
 - 2) Due to the external devices at fault (Actuator, fuel injection device, turbine, etc) rectify the mechanical devices.

8. Fuel system

System inoperative

If the engine governing system does not function, the fault may be determined by performing the voltage tests described in steps 1, 2 and 3. (+) and (-) refer to meter polarity. If normal values should be indicated as a result of following the troubleshooting steps, the fault may be with the actuator or the wiring to the actuator. In that case, check the actuator.

Step	Terminal	When to Take the Reading	Normal readings	Probable Cause of Abnormal Reading	Solution
1	F(+) & E(-)	When the engine stopped	DC 24V		1. Check battery line 2. Replace battery
2	F(+) & E(-)	When starting the engine	DC 15V or above	1. Low battery voltage	1. Check battery line
				2. Wiring error	2. Replace battery
3	C & D	When the engine stopped	300~1200Ω (tester ohmmeter)	1. Defective speed sensor	1. Check sensor line
				2. Improper or defective wiring to the speed sensor	2. Replace speed sensor
4	C & D	When starting the engine	1.5V or above (tester AC voltmeter)	1. The gap between speed sensor and gear teeth too great.	1. Check sensor line
				2. Defective speed sensor	2. Replace speed sensor
5	A & B	When the engine stopped	3.8~4.5Ω (tester ohmmeter)	1. If the voltage reading is below 3.8Ω => Short	1. Check short/open actuator
				2. If the voltage reading is above 4.8Ω => Open wire	2. Replace actuator
				3. Defective actuator	
6	P(+) & G(-)	KEY S/W ON	DC 9.5~10.5V	Defective speed controller	Replace controller
7	F(+) & A(-)	When starting the engine	DC 9~15V in normal conditions DC 1~3V in abnormal conditions	1. Speed adjustment set too low.	1. Check speed setting
				2. Short/open in actuator wiring	2. Check actuator line
				3. Actuator	3. Replace actuator when found to be defective

8. Fuel system

Adjustment Fuel Injection Pump

1. DP158L (60Hz)

1) Fuel injection pump : 65.11101-7301 (0 402 618 813)

- Model : PE8P120A500/4LS7935 (0 412 628 937)
- Governor : Doosan electronic governor
- Plunger & Barrel : 2 418 455 545
- Delivery valve : 2 418 559 045
- Feed pump : FP/KD22P78-2 (0 440 008 152)

- Prestroke : 4.5 ± 0.05 mm (13 ± 1.5 mm)

2) Nozzle holder assembly : 65.10101-7051 (0 432 131 667)

3) Nozzle : 65.10102-6047 (0 433 171 174)

4) Injection pipe : 420208-00453, 420208-00454

5) Firing order : 1 - 5 - 7 - 2 - 6 - 3 - 4 - 8

6) Fuel injection timing : BTDC 23°

(A)Test condition for injection pump	Nozzle & Holder Ass'y	1688 901 019	Opening pressure : 210 bar
	Injection pipe (ID X OD - L)	-	Ø3.0 x Ø8.0-1,000 mm
	Test oil	ISO4113	Temperature : 40 ± 5 °C
(B)Engine standard parts	Nozzle & Holder Ass'y	65.10101-7051	Nozzle (4 x Ø0.40)Opening pressure : 280 bar
	Injection pipe (ID X OD -L)	420208-00453, 420208-00454	Ø2.0 x Ø6.35-750 mm

Rack diagram and setting valve at each point

	Check Point	Rack Position (mm)	Pump Speed (rpm)	Injection Q'ty on RIG (mm ³ /1,000st)		Pressure (mmHg)
				(A)Test (mmHg) condition for Inj. pump	(B)Engine standard parts	
Stand by Power	A	16.0	900	432	-	-
	-	-	-	-	-	-
	-	-	-	-	-	-
	-	-	-	-	-	-
	-	-	-	-	-	-
	-	-	-	-	-	-

8. Fuel system

2. DP158L (50Hz) • Prestroke : 4.5 ± 0.05 mm (13 ± 1.5 mm)
- 1) Fuel injection pump : 65.11101-7301 (0 402 618 813)
- Model : PE8P120A500/4LS7935 (0 412 628 937)
 - Governor : Doosan electronic governor
 - Plunger & Barrel : 2 418 455 545
 - Delivery valve : 2 418 559 045
 - Feed pump : FP/KD22P78-2 (0 440 008 152)
- 2) Nozzle holder assembly : 65.10101-7051 (0 432 131 667)
- 3) Nozzle : 65.10102-6047 (0 433 171 174)
- 4) Injection pipe : 420208-00453, 420208-00454
- 5) Firing order : 1 - 5 - 7 - 2 - 6 - 3 - 4 - 8
- 6) Fuel injection timing : BTDC 18°

(A)Test condition for injection pump	Nozzle & Holder Ass'y	1688 901 019	Opening pressure : 210 bar
	Injection pipe (ID X OD - L)	-	Ø3.0 x Ø8.0-1,000 mm
	Test oil	ISO4113	Temperature : 40 ± 5 °C
(B)Engine standard parts	Nozzle & Holder Ass'y	65.10101-7051	Nozzle (4 x Ø0.40)Opening pressure : 280 bar
	Injection pipe (ID X OD -L)	420208-00453, 420208-00454	Ø2.0 x Ø6.35-750 mm

Rack diagram and setting valve at each point

	Check Point	Rack Position (mm)	Pump Speed (rpm)	Injection Q'ty on RIG (mm ³ /1,000st)		Pressure (mmHg)
				(A)Test (mmHg) condition for Inj. pump	(B)Engine standard parts	
Stand by Power	A	16.3	750	466	-	-
	-	-	-	-	-	-
	-	-	-	-	-	-
	-	-	-	-	-	-
	-	-	-	-	-	-
	-	-	-	-	-	-

8. Fuel system

3. DP180L (60Hz)

1) Fuel injection pump : 65.11101-7302 (0 402 619 802 Bosch)

- Model : PE10P120A500LS7936 (0 412 629 815)
- Governor : Doosan electronic governor
- Plunger & Barrel : 2 418 455 545
- Delivery valve : 2 418 559 045
- Feed pump : FP/KD22P80-1 (0 440 008 090), FP/KD22P78-2 (0 440 008 152)

• Prestroke : 4.5 ± 0.05 mm (13 ± 1.5 mm)

- 2) Nozzle holder assembly : 65.10101-7051 (0 432 131 667)
- 3) Nozzle : 65.10102-6047 (0 433 171 174)
- 4) Injection pipe : 420208-00399, 420208-00400
- 5) Firing order : 1 - 6 - 5 - 10 - 2 - 7 - 3 - 8 - 4 - 9
- 6) Fuel injection timing : BTDC 21°

(A)Test condition for injection pump	Nozzle & Holder Ass'y	1688 901 015	Opening pressure : 208.5 ± 1.5 bar
	Injection pipe (ID X OD - L)	-	$\varnothing 3.0$ x $\varnothing 8.0$ -600 mm
	Test oil	ISO4113	Temperature : 40 ± 5 °C
(B)Engine standard parts	Nozzle & Holder Ass'y	65.10101-7051	Nozzle (4 x $\varnothing 0.40$)Opening pressure : 280 bar
	Injection pipe (ID X OD -L)	420208-00399, 420208-00400	$\varnothing 2.0$ x $\varnothing 6.35$ -800 mm

Rack diagram and setting valve at each point

	Check Point	Rack Position (mm)	Pump Speed (rpm)	Injection Q'ty on RIG ($\text{mm}^3/1,000\text{st}$)		Pressure (mmHg)
				(A)Test (mmHg) condition for Inj. pump	(B)Engine standard parts	
Stand by Power	A	14.6	900	383	-	-
	-	-	-	-	-	-
	-	-	-	-	-	-
	-	-	-	-	-	-
	-	-	-	-	-	-
	-	-	-	-	-	-

8. Fuel system

4. DP180L (50Hz)
- Prestroke : 4.5 ± 0.05 mm (13 ± 1.5 mm)
- 1) Fuel injection pump : 65.11101-7302 (0 402 619 802 Bosch)
- Model : PE10P120A500LS7936 (0 412 629 815)
 - Governor : Doosan electronic governor
 - Plunger & Barrel : 2 418 455 545
 - Delivery valve : 2 418 559 045
 - Feed pump : FP/KD22P80-1 (0 440 008 090), FP/KD22P78-2 (0 440 008 152)
- 2) Nozzle holder assembly : 65.10101-7051 (0 432 131 667)
- 3) Nozzle : 65.10102-6047 (0 433 171 174)
- 4) Injection pipe : 420208-00399, 420208-00400
- 5) Firing order : 1 - 6 - 5 - 10 - 2 - 7 - 3 - 8 - 4 - 9
- 6) Fuel injection timing : BTDC 19°

(A)Test condition for injection pump	Nozzle & Holder Ass'y	1688 901 019	Opening pressure : 210 bar
	Injection pipe (ID X OD - L)	-	Ø3.0 x Ø8.0-1,000 mm
	Test oil	ISO4113	Temperature : 40 ± 5 °C
(B)Engine standard parts	Nozzle & Holder Ass'y	65.10101-7051	Nozzle (4 x Ø0.40)Opening pressure : 280 bar
	Injection pipe (ID X OD -L)	420208-00399, 420208-00400	Ø2.0 x Ø6.35-800 mm

Rack diagram and setting valve at each point

	Check Point	Rack Position (mm)	Pump Speed (rpm)	Injection Q'ty on RIG (mm ³ /1,000st)		Pressure (mmHg)
				(A)Test (mmHg) condition for Inj. pump	(B)Engine standard parts	
Stand by Power	A	14.7	750	405	-	-
	-	-	-	-	-	-
	-	-	-	-	-	-
	-	-	-	-	-	-
	-	-	-	-	-	-
	-	-	-	-	-	-

8. Fuel system

5. DP222L (60Hz)
- 1) Fuel injection pump : 65.11101-7303 (0 402 619 807)
- Model : PE12P120A500LS7937 (0 412 620 854)
 - Governor : GAC electronic governor
 - Plunger & Barrel : 2 418 455 545
 - Delivery valve : 2 418 559 045
 - Feed pump : FP/KD22P80-1 (0 440 008 090),
FP/KD22P78-2 (0 440 008 152)
 - Prestroke : 4.5 ± 0.05 mm (13 ± 1.5 mm)
- 2) Nozzle holder assembly : 65.10101-7051 (0 432 131 667)
- 3) Nozzle : 65.10102-6047 (0 433 171 174)
- 4) Injection pipe : 420208-00445, 420208-00443,
420208-00441
- 5) Firing order : 1 - 12 - 5 - 8 - 3 - 10 - 6 - 7 - 2 -
11 - 4 - 9
- 6) Fuel injection timing : BTDC 21°

(A)Test condition for injection pump	Nozzle & Holder Ass'y	1688 901 019	Opening pressure : 210 bar
	Injection pipe (ID X OD - L)	-	Ø3.0 x Ø8.0-1,000 mm
	Test oil	ISO4113	Temperature : 40 ± 5 °C
(B)Engine standard parts	Nozzle & Holder Ass'y	65.10101-7051	Nozzle (4 x Ø0.40)Opening pressure : 280 bar
	Injection pipe (ID X OD -L)	420208-00445, 420208-00443, 420208-00441	Ø2.0 x Ø6.35-850 mm

Rack diagram and setting valve at each point

	Check Point	Rack Position (mm)	Pump Speed (rpm)	Injection Q'ty on RIG (mm ³ /1,000st)		Pressure (mmHg)
				(A)Test (mmHg) condition for Inj. pump	(B)Engine standard parts	
Stand by Power	A	16.0	900	430	-	-
	-	-	-	-	-	-
	-	-	-	-	-	-
	-	-	-	-	-	-
	-	-	-	-	-	-

8. Fuel system

6. DP222L (50Hz)
- 1) Fuel injection pump : 65.11101-7303 (0 402 619 807)
- Model : PE12P120A500LS7937 (0 412 620 854)
 - Governor : GAC electronic governor
 - Plunger & Barrel : 2 418 455 545
 - Delivery valve : 2 418 559 045
 - Feed pump : FP/KD22P80-1 (0 440 008 090),
FP/KD22P78-2 (0 440 008 152)
 - Prestroke : 4.5 ± 0.05 mm (13 ± 1.5 mm)
- 2) Nozzle holder assembly : 65.10101-7051 (0 432 131 667)
- 3) Nozzle : 65.10102-6047 (0 433 171 174)
- 4) Injection pipe : 420208-00445, 420208-00443,
420208-00441
- 5) Firing order : 1 - 12 - 5 - 8 - 3 - 10 - 6 - 7 - 2 -
11 - 4 - 9
- 6) Fuel injection timing : BTDC 19°

(A)Test condition for injection pump	Nozzle & Holder Ass'y	1688 901 019	Opening pressure : 210 bar
	Injection pipe (ID X OD - L)	-	Ø3.0 x Ø8.0-1,000 mm
	Test oil	ISO4113	Temperature : 40 ± 5 °C
(B)Engine standard parts	Nozzle & Holder Ass'y	65.10101-7051	Nozzle (4 x Ø0.40)Opening pressure : 280 bar
	Injection pipe (ID X OD -L)	420208-00445, 420208-00443, 420208-00441	Ø2.0 x Ø6.35-850 mm

Rack diagram and setting valve at each point

	Check Point	Rack Position (mm)	Pump Speed (rpm)	Injection Q'ty on RIG (mm ³ /1,000st)		Pressure (mmHg)
				(A)Test (mmHg) condition for Inj. pump	(B)Engine standard parts	
Stand by Power	A	15.5	750	435	-	-
	-	-	-	-	-	-
	-	-	-	-	-	-
	-	-	-	-	-	-
	-	-	-	-	-	-

9. Intake/exhaust system

General information	155
General Information	155
Specifications	156
General information	155
Construction	157
Function	158
Failure Diagnosis	159
How to Maintain Turbocharger	162
Special inspection of turbocharger	163

9. Intake/exhaust system

General information

General Information

The exhaust gas of the engine passes through the turbine wing of turbocharger to rotate the turbine. At the same time, the impeller air of the compressor mounted on the other end of same shaft rotates to suck in the fresh air through air filter, and delivers it to the cylinder through inter cooler with high pressure.

The turbocharger is air-cooled. The bearing is lubricated by the lubricant supplied from the engine lubrication system.

The engine power depends on the supplied fuel amount and engine efficiency.

In order to make the supplied fuel burned completely to work for the engine efficiently, the sufficient air should be delivered to the cylinder. That is, the engine power is virtually determined by the size of cylinder. If compressed air is delivered to the cylinder with a given capacity, the air amount in the cylinder increases to burn more fuel, thereby increasing the engine power.

The method of compressing the air to supply it into the engine cylinder is called supercharging; and the method of using the exhaust gas discharged from the combustion chamber for the same purpose is called turbocharging.

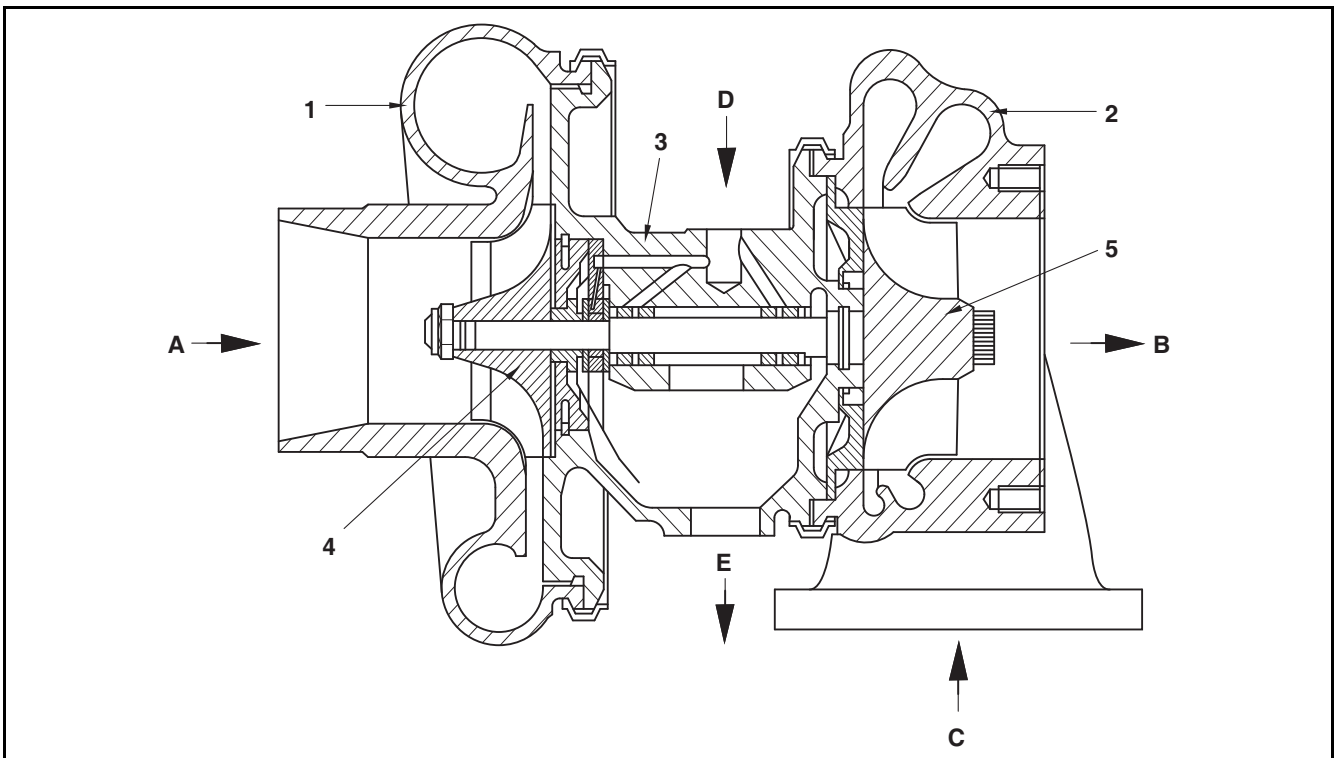

DV2213107A

No.	Name	No.	Name
1.	Compressor casing	A.	Air inlet
2.	Turbine casing	B.	Exhaust gas outlet
3.	Compressor wheel	C.	Exhaust gas inlet
4.	Impeller	D.	Engine oil delivery
5.	Turbine	E.	Engine oil recovery

9. Intake/exhaust system

Specifications

Item	DP158L				Remarks
	DP158LCS	DP158LCF	DP158LDS	DP158LDF10	
Intake/Exhaust System					
Max. back pressure (kPa)		5.9			
Max. intake air restriction (kPa)	With clean filter element	2.16			
	With dirty filter element	6.23			

Item	DP180L				Remarks
	DP180LBS	DP180LBF	DP180LAS	DP180LAF	
Intake/Exhaust System					
Max. back pressure (kPa)		5.9			
Max. intake air restriction (kPa)	With clean filter element	2.16			
	With dirty filter element	6.23			

Item	DP222L					Remarks
	DP222LAS	DP222LBS	DP222LBF	DP222LCS	DP222LCF	
Intake/Exhaust System						
Max. back pressure (kPa)		5.9				
Max. intake air restriction (kPa)	With clean filter element	2.16				
	With dirty filter element	6.23				

Generator Engine	DP158L	DP180L	DP222L
Turbocharger Model	Alied Signal T40E	Alied Signal T45E	Alied Signal TV51
Allowable max. RPM (rpm)	111,800	92,200	82,000
Intake Air Quantity (m ³ /sec)	0.26	0.32	0.40
Compression Efficiency (%)	75.5	75.0	77.5
Compression Ratio	3.00	2.80	2.90

9. Intake/exhaust system

General information

Construction

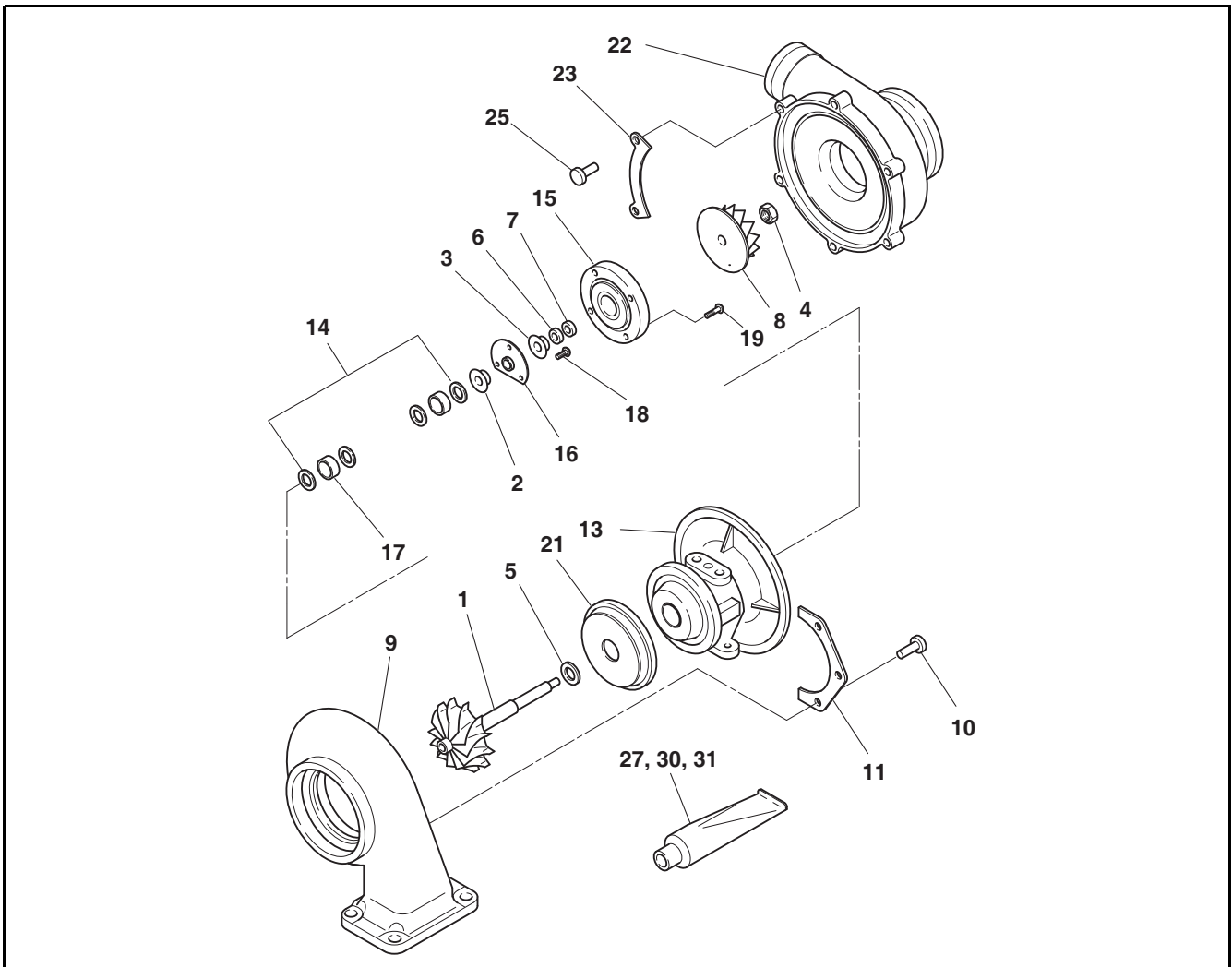

DV2213108A

No.	Name	No.	Name	No.	Name
1.	Turbine shaft	10.	Bolt	21.	Heat screen
2.	Thrust bush	11.	Clamp	22.	Compressor housing
3.	Oil shut off	13.	Bearing housing	23.	Clamp
4.	Fixing nut	14.	Retainer ring	24.	Bolt
5.	Seal ring	15.	Seal plate	27.	Liquid gasket
6.	Seal ring	16.	Thrust bearing	30.	Loctite
7.	Seal ring	17.	Journal bearing	31.	Liquid anti-burn angents
8.	Compressor wing wheel	18.	Screw		
9.	Turbine housing	19.	Screw		

9. Intake/exhaust system

Function

1. Turbine

The exhaust gas that is discharged from combustion chamber passes through turbine housing conveying an energy to turbine wings to give the rotating power, This is called as the turbine and in order not to influence a bad effect at bearing part, there are the seal ring and heat dissipator.

2. Compressor

It is connected to the same shaft with the turbine to make a revolving assembly, and receive the revolving force of turbine, and sends air to the suction manifold by suctioning and compressing it. This is called as the compressor.

3. Bearing

- 1) Thrust bearing force is applied to the turbine wheel and an arrangement is made for the shaft not to shift.
- 2) journal bearing (floating bearing) is adopted and it forms the double oil films at the in out surfaces in comparison to the general stationary type so that the bearing may be able to rotate independently and consequently the double layers of films act as the damper to make the slipping speed on the bearing surface less than the rotating speed of shaft so that the dynamic stability may be obtained.

4. Sealing at compressor shaft

In order for the compressed intake air and lubricating oil not to leak, a seal plate and a seal ring are made to the double structures.

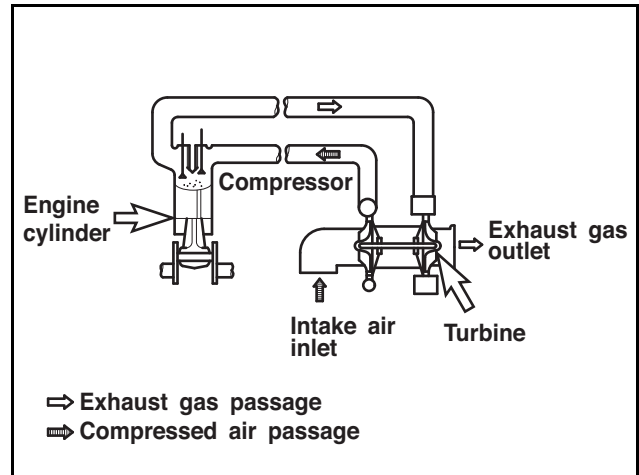

DV2213110A_E

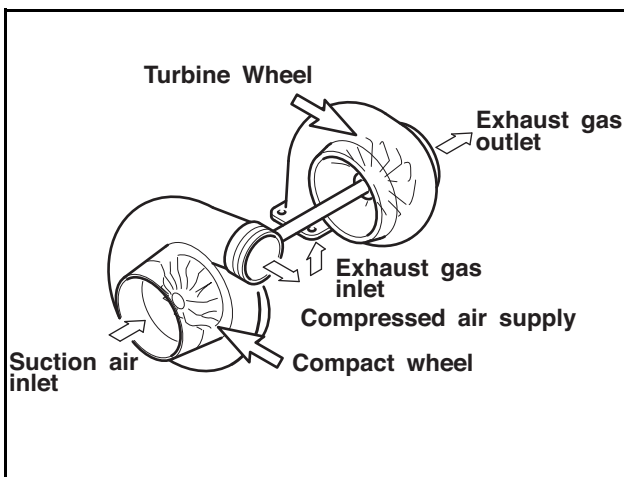

DV2213109A_E

9. Intake/exhaust system

Failure Diagnosis

Phenomenon	Causes	Troubleshooting
Noise or vibration	Rotating part is contacted	Repair or replace it
	Unbalanced rotation of a rotor	Repair or replace it
	Burn	Repair or replace it
	Loose joint	Check or repair it
	Deformed or damaged intake system hose	Replace it
	Poor clamping state	Adjust and tighten the clamp
	Contaminated or damaged air filter	Replace and check if the impeller of the turbocharger is damaged
	Leakage of coolant from the turbocharger or oil from the oil hose	Replace the hose and the gasket
	Leakage of gas from the exhaust manifold	Replace the gasket or tighten the fixing nut
	Poor turbo actuator operation	Replace the turbocharger
	Leakage from the engine block and the exhaust manifold	Check the engine
	Contaminated blowby gas and abnormal oil amount	Check the turbo impeller and the turbo intake outlet
	Large gap of the turbocharger wheel, causing interference with the wall	Check if there is any sand or metallic foreign substance
	Damaged turbocharger wheel	Check if there is any sand or metallic foreign substance
Damaged wheel and shaft of the turbocharger	Check if there is any sand or metallic foreign substance	
Poor rotating force of the turbocharger wheel	Check if there is any sand or metallic foreign substance	

9. Intake/exhaust system

Phenomenon	Causes	Troubleshooting
Lowered output	Leakage of gas from each part of the exhaust system	Check or repair it
	Clogged air filter element	Replace or clean it
	Contaminated or damaged turbocharger	Repair or replace it
	Leakage of air from the discharging part of the compressor shaft	Check or repair it
	Deformed or damaged intake system hose	Replace it
	Poor clamping state	Adjust and tighten the clamp
	Contaminated or damaged air filter	Replace and check if the impeller of the turbocharger is damaged
	Poor turbo actuator operation	Replace the turbocharger
	Leakage from the engine block and the exhaust manifold	Check the engine
	Contaminated blowby gas and abnormal oil amount	Check the turbo impeller and the turbo intake outlet
	Large gap of the turbocharger wheel, causing interference with the wall	Check if there is any sand or metallic foreign substance
	Damaged turbocharger wheel	Check if there is any sand or metallic foreign substance
	Damaged wheel and shaft of the turbocharger	Check if there is any sand or metallic foreign substance
Poor rotating force of the turbocharger wheel	Check if there is any sand or metallic foreign substance	
Oil leakage	Deformed or damaged intake system hose	Replace it
	Poor clamping state	Adjust and tighten the clamp
	Contaminated or damaged air filter	Replace and check if the impeller of the turbocharger is damaged
	Leakage of coolant from the turbocharger or oil from the oil hose	Replace the hose and the gasket
	Poor turbo actuator operation	Replace the turbocharger

9. Intake/exhaust system

Phenomenon	Causes	Troubleshooting
Oil leakage	Leakage from the engine block and the exhaust manifold	Check the engine
	Contaminated blowby gas and abnormal oil amount	Check the turbo impeller and the turbo intake outlet
	Large gap of the turbocharger wheel, causing interference with the wall	Check if there is any sand or metallic foreign substance
	Damaged turbocharger wheel	Check if there is any sand or metallic foreign substance
	Damaged wheel and shaft of the turbocharger	Check if there is any sand or metallic foreign substance
	Poor rotating force of the turbocharger wheel	Check if there is any sand or metallic foreign substance
Oil consumption	Poor clamping state	Adjust and tighten the clamp
	Leakage of coolant from the turbocharger or oil from the oil hose	Replace the hose and the gasket
	Leakage from the engine block and the exhaust manifold	Check the engine
	Contaminated blowby gas and abnormal oil amount	Check the turbo impeller and the turbo intake outlet
	Large gap of the turbocharger wheel, causing interference with the wall	Check if there is any sand or metallic foreign substance
	Damaged turbocharger wheel	Check if there is any sand or metallic foreign substance
	Damaged wheel and shaft of the turbocharger	Check if there is any sand or metallic foreign substance
	Poor rotating force of the turbocharger wheel	Check if there is any sand or metallic foreign substance

9. Intake/exhaust system

Phenomenon	Causes	Troubleshooting
Black and white emissions	Deformed or damaged intake system hose	Replace it
	Contaminated or damaged air filter	Replace and check if the impeller of the turbocharger is damaged
	Leakage of coolant from the turbocharger or oil from the oil hose	Replace the hose and the gasket
	Poor turbo actuator operation	Replace the turbocharger
	Contaminated blowby gas and abnormal oil amount	Check the turbo impeller and the turbo intake outlet
	Large gap of the turbocharger wheel, causing interference with the wall	Check if there is any sand or metallic foreign substance
	Damaged turbocharger wheel	Check if there is any sand or metallic foreign substance
	Damaged wheel and shaft of the turbocharger	Check if there is any sand or metallic foreign substance
Blue emissions	Leakage from the engine block and the exhaust manifold	Check the engine
	Poor rotating force of the turbocharger wheel	Check if there is any sand or metallic foreign substance
Too much fog	Oil leakage to the turbine or compressor	Repair or replace it
	Worn or damaged seal ring due to worn bearing	Repair or replace it
Too much exhaust emissions	Clogged air filter element	Replace or clean it
	Clogged air duct	Check or repair it
	Air leakage from the intake system	Check or repair it
	The turbocharger cannot rotate because of burning	Repair or replace it
	A turbine blade or compression wing contacts with the other one or is damaged	Repair or replace it
	Deformed or clogged exhaust system pipe	Check or repair it

How to Maintain Turbocharger

1. Cautions for engine operation
 - 1) Observe the followings when starting, operating, and stopping an engine.

9. Intake/exhaust system

Item	Cautions	Reasons
Starting an engine	1) Check the oil amount	
	2) Therefore, start the engine with the starter motor to check the rise of oil pressure (until the gradation of the oil pressure gauge moves or the pressure indicator lamp is turned on).	2) Overhasty start of engine leads to engine rotation without lubricating turbocharger and other engine parts, causing abnormal wear or burning of bearings.
	3) If you replace oil, oil filter cartridge, or lubrication system parts or use an engine in cold areas, or the engine has stopped for a long period, loosen the oil pipe joint at the inlet of the turbocharger and run the starter motor until oil flows out. After completing the work, tighten the oil pipe joint again and start the engine.	3) When an engine has stopped or kept cold for a long period, circulation of oil in the pipe gets poor.
After starting an engine	1) Operate the engine at idle for five minutes from starting it.	1) When the engine is suddenly loaded while the engine and the turbocharger have not been smoothly rotated after starting the engine, parts with insufficient oil may be burnt.
	2) Check if oil, gas, or air is leaked from each part. If so, take proper action.	2) Leakage of oil, gas, or air (especially oil) reduces oil pressure and loss of oil cause burning of bearings.
During Operation	check the following.	
	1) Oil pressure At idle: 1.5 ~ 3.0 kg/cm ² Fully loaded: 3.0 ~ 5.5 kg/cm ²	1) Too low oil pressure causes abnormal wearing or burning of bearings. Too high oil pressure causes oil leakage.
	2) When abnormal noise or vibration occurs, slowly reduce the rotate count until the engine stops and then figure out the causes.	2) Operating an engine with noise or vibration may cause irreversible damage of the engine.
Stopping an Engine	1) Operate the engine at idle for five minutes before stopping it.	1) Sudden engine stop after operating the engine under high load allows the heat from the red-heated turbine blade to be delivered to the bearing system. Then oil burns and the bearing metal and rotation shaft are burnt.

Special inspection of turbocharger

You should check the radial and axial clearance of a rotor. This preventive action is to find the bearing wear status of the axial clearance so as to prevent the severe damage to the rotor and bearing.

9. Intake/exhaust system

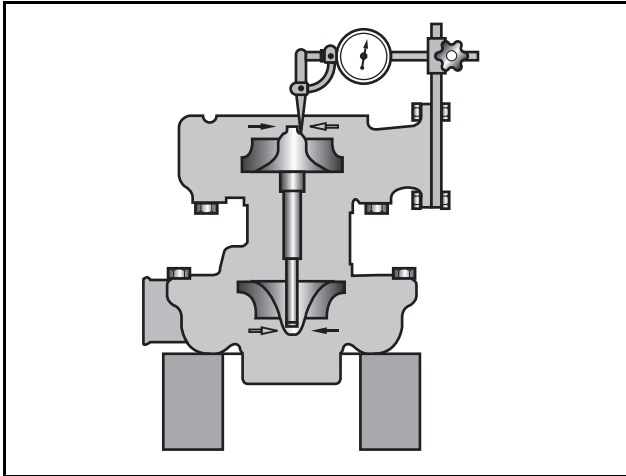

DV2213034A

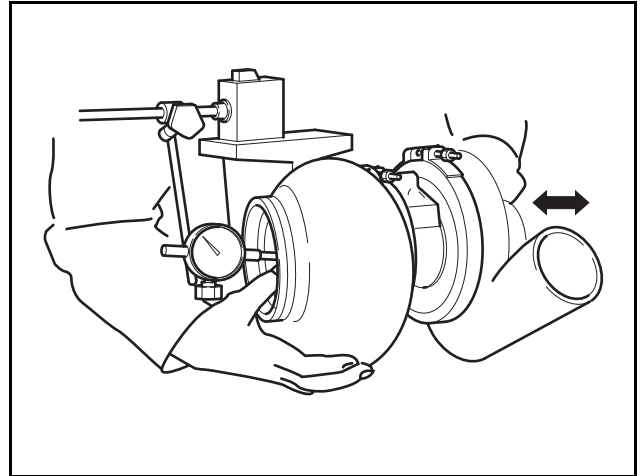

DV2213036A

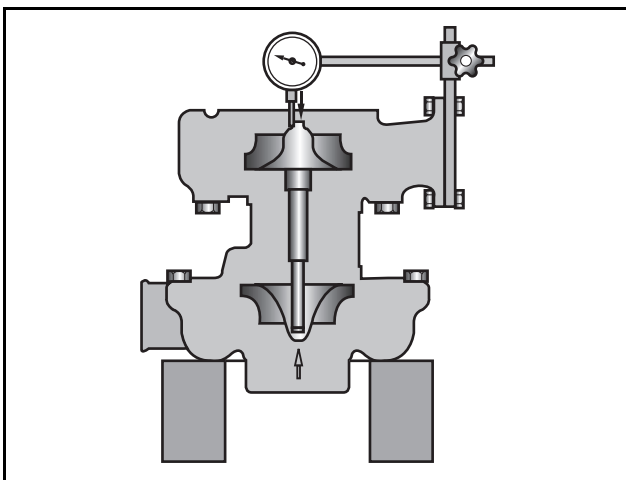

DV2213035A

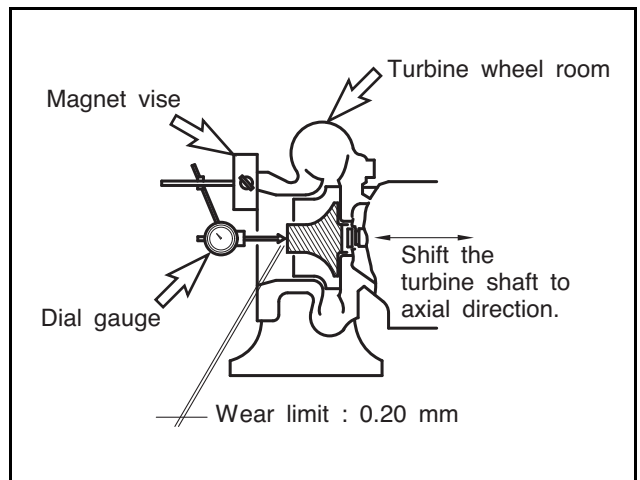

DV2213037A_E

1. Checking the rotating state of a rotor assembly Check its rotating state when strange noise is heard during rotation. If you use a sound rod, contact the neb of the sound rod to the turbocharger housing and slowly raise the RPM. If high-pitched sound continues, it means that the state is abnormal. In this case, the bearing or the rotor assembly may be abnormal. So you need to replace or repair the turbocharger.
2. Checking the play of rotor assembly Remove a turbocharger from the engine, and check the axial and radial play of the rotor assembly. When you disassemble the turbocharger, be sure to seal the oil inlet and outlet with a tape, etc.

1) Axial play of the rotor assembly

Wear limit	0.20 mm
------------	---------

2) Radial clearance

Wear limit	0.65 mm
------------	---------

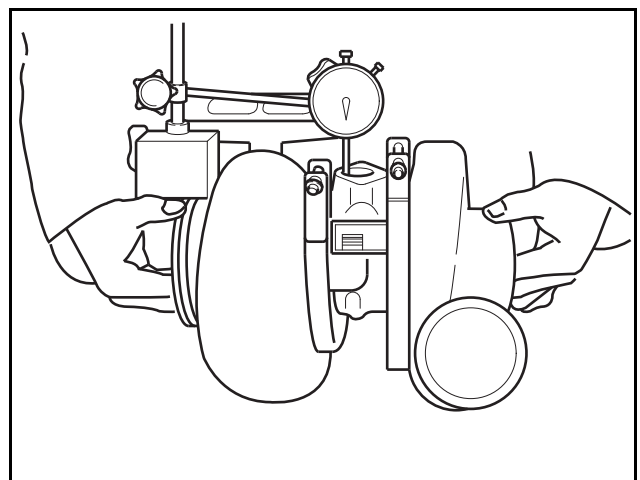

DV2213038A

9. Intake/exhaust system

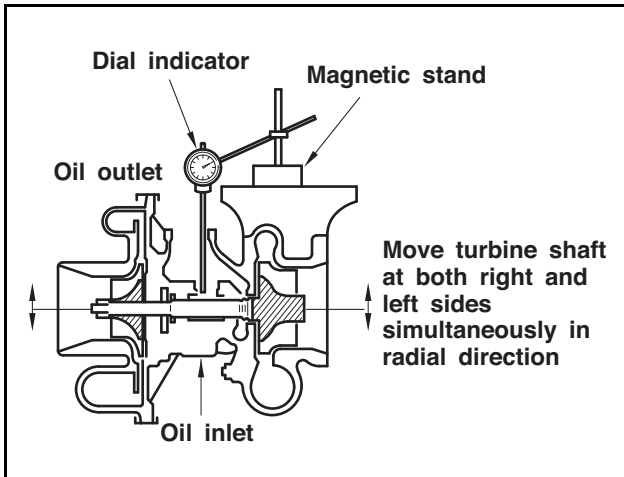

DV2213039A_E

- 3) In case that the end plays to axial and circumference directions, replace or repair the turbocharger.

10. Cylinder block/head

General information	169
General Information	169
Specifications	169
Cylinder block	171
Check of Cylinder Block	171
Measurement of Cylinder Liner	171
Cylinder head.	172
Measurement of Cylinder Liner	172
Assembly of Cylinder Head.	172
Check of Cylinder Head	172
Valve	174
General Information	174
Check of Valve	174
Check of Valve Guide	174
Valve Seat.	175
Valve Spring	175
Rocker arm	177
Disassembly Rocker Arm	177
Assembly Rocker Arm	177
Check of Rocker Arm.	177
Tappet and push rod.	178
Tappet Clearance	178
Visual inspection of tappet	178
Warpage of Push Rod	178
Camshaft	179
Camshaft End Play	179
Check of Cam	179
Check of camshaft.	179

10. Cylinder block/head

General information

General Information

The cylinder block is a single piece of alloy cast iron. To increase its stiffness, it is extended to a level below the crankshaft center line. The engine has replaceable wet cylinder liners and individual cylinder heads with strung-in valve seat rings and replaceable valve guides.

Specifications

Item	DP158L				Remarks	
	DP158LCS	DP158LCF	DP158LDS	DP158LDF10		
Cylinder block/head						
Valve system type		Overhead valve type				
No. of valve (per cylinder)	Intake	1				
	Exhaust	1				
Valve lashes (at cold) (mm)	Intake	0.25				
	Exhaust	0.35				
Intake valve (°)	Opening	24° (BTDC)				
	Close	36° (ABDC)				
Exhaust valve (°)	Opening	63° (BBDC)				
	Close	27° (ATDC)				

Item	DP180L				Remarks	
	DP180LBS	DP180LBF	DP180LAS	DP180LAF		
Cylinder block/head						
Valve system type		Overhead valve type				
No. of valve (per cylinder)	Intake	1				
	Exhaust	1				
Valve lashes (at cold) (mm)	Intake	0.25				
	Exhaust	0.35				
Intake valve (°)	Opening	24° (BTDC)				
	Close	36° (ABDC)				
Exhaust valve (°)	Opening	63° (BBDC)				
	Close	27° (ATDC)				

10. Cylinder block/head

Item		DP222L					Remarks
		DP222LAS	DP222LBS	DP222LBF	DP222LCS	DP222LCF	
Cylinder block/head							
Valve system type		Overhead valve type					
No. of valve (per cylinder)	Intake	1					
	Exhaust	1					
Valve lashes (at cold) (mm)	Intake	0.25					
	Exhaust	0.35					
Intake valve (°)	Opening	24° (BTDC)					
	Close	36° (ABDC)					
Exhaust valve (°)	Opening	63° (BBDC)					
	Close	27° (ATDC)					

Cylinder block

Check of Cylinder Block

1. Cleanse the cylinder block and check if there is any cracked or damaged part with naked eye.
2. Replace the cylinder block if it is seriously cracked or damaged. Repair tiny cracks if existing.
3. Check if the oil path or coolant path is clogged or corroded.
4. Perform the hydrostatic test to check whether there is a crack or an air leakage.
5. Block the discharging outlets of the cooling water path and the oil path of the cylinder block and put pressure of 4 kg/cm^2 on the inlet. Then sink the cylinder block in the $70 \text{ }^\circ\text{C}$ water for 1 minute and check if air leaks.

Measurement of Cylinder Liner

1. Assembly the cylinder liner at the cylinder block and measure inner diameter at upper, middle, lower that is, 3 step by 45° interval.

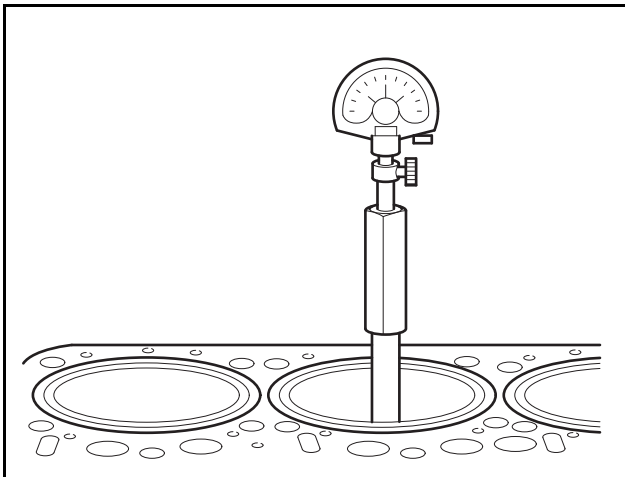

DV2213111A

2. Calculate the average values after eliminating the maximum and minimum values.
3. If the measured values are very close to the limit value or beyond, replace it.

Standard	Limit
$\text{Ø}127.990 \sim \text{Ø}128.010\text{mm}$	0.15mm

10. Cylinder block/head

Cylinder head

Measurement of Cylinder Liner

1. Remove the cotter pin pressing the valve spring by means of a special tool.

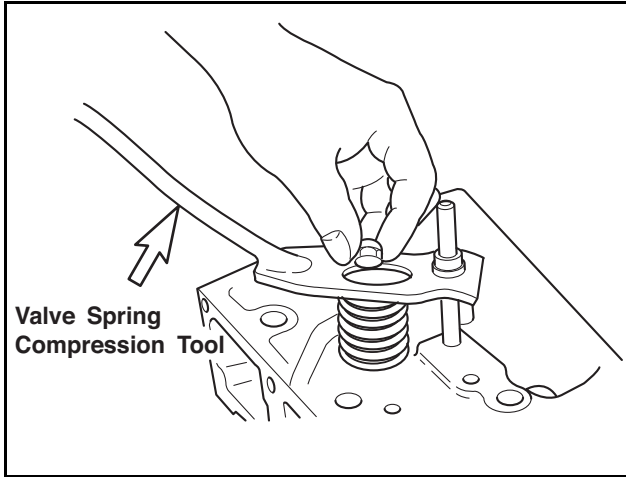

DV2213112A_E

⚠ CAUTION

Be careful not to damage the cylinder gasket.

2. Remove out the valve stem seal.
3. Remove the intake valve and the exhaust valve.
4. Remove the valve guide from the cylinder head combustion with the special tool.

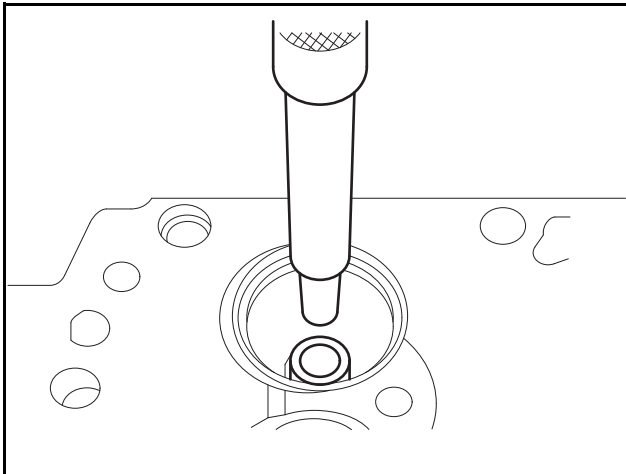

DV2213113A

Assembly of Cylinder Head

1. Clean the cylinder head.
2. Apply engine oil on the valve stem and the valve guide, and then attach the valve.

3. Replace the new valve stem seal and then attach the stem seal to the valve guide of the cylinder head with the special tool.

⚠ CAUTION

Be careful not to damage the valve stem seal.

4. Attach the valve spring washer to valve guide.
5. Put in the inner and outer spring and then attach the valve spring plate on the springs.

⚠ CAUTION

The yellow mark on the valve spring is upward.

6. Attach the valve cotter with the valve spring compress tool.
7. Check if the valve cotters have been positioned correctly with the plastic hammer after completing attaching them.

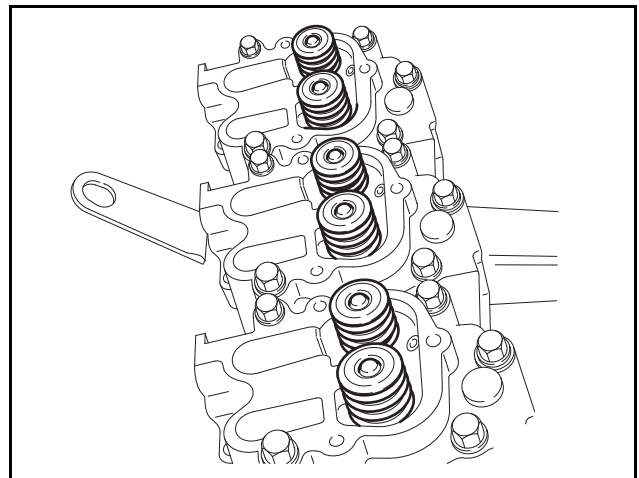

DV2213114A

Check of Cylinder Head

1. Checking cylinder head
 - 1) Check cracks or damage of the cylinder head.
 - 2) Remove carbon from the bottom surface of the cylinder head. Here, be careful not to scratch the valve seat surface.

⚠ CAUTION

Be careful not to scratch the valve seat surface.

10. Cylinder block/head

3) For cracks or damage which cannot be checked with the naked eye, perform the hydrostatic test or the magnetic particle testing.

Note) Hydraulic test is same as for cylinder block.

2. Distortion at the lower face

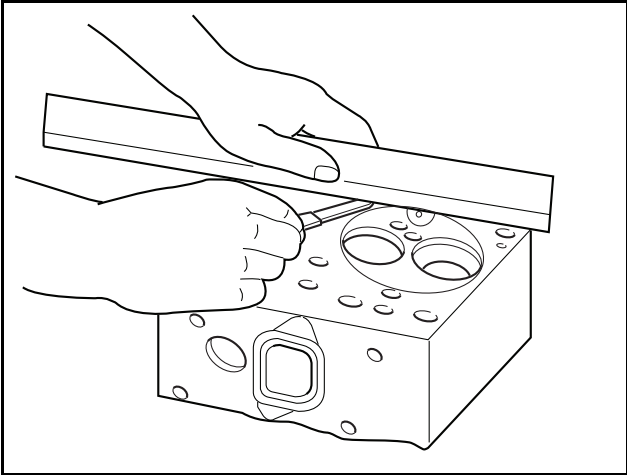

DV2213115A

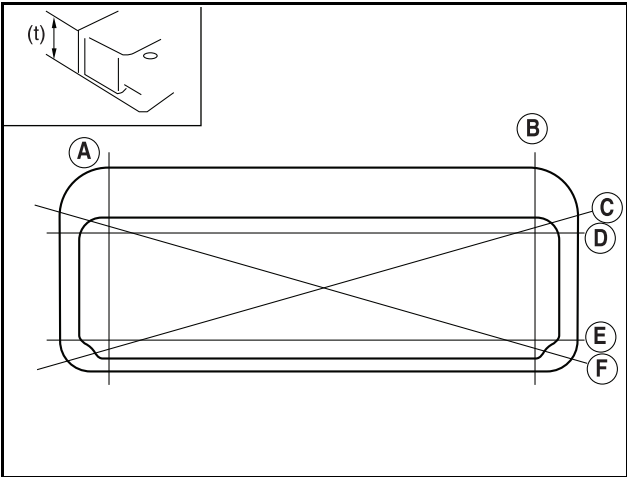

DV2213116A

- 1) Measure the amount of distortion using a straight edge and a feeler gauge at six positions as shown in the figure.
- 2) If the measured value exceeds the maximum allowable limit, replace the cylinder head.

Standard	Limit
Below 0.05mm	0.2mm

10. Cylinder block/head

Valve

General Information

The overhead valves are actuated via chilled cast iron tapets, push rods and rocker arms from the camshaft.

Check of Valve

After cleaning the valves with clean diesel oil, measure the valve as follow.

1. Measure the valve stem's outside diameter at upper, middle, and lower to determine the wears and when the wear limit is more than limit, replace the valves.

Item	Standard	Limit
In.	Ø11.969 ~ Ø11.980mm	Ø11.830mm
Ex.	Ø11.945 ~ Ø11.955mm	Ø11.805mm

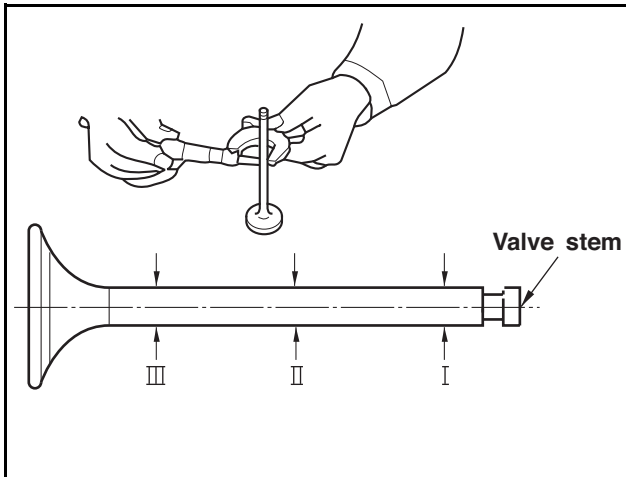

DV2213117A_E

2. inspect the scratch and wear of valve stem seal contacting face, and if necessary correct with the grinding paper but if severe replace it.
3. if valve head thickness becomes less than limit, replace the valve.

Item	Standard	Limit
In.	2.6 ~ 3.0mm	1.6mm
Ex.	1.9 ~ 2.3mm	1.3mm

CAUTION

If the damage is severe, replace new one.

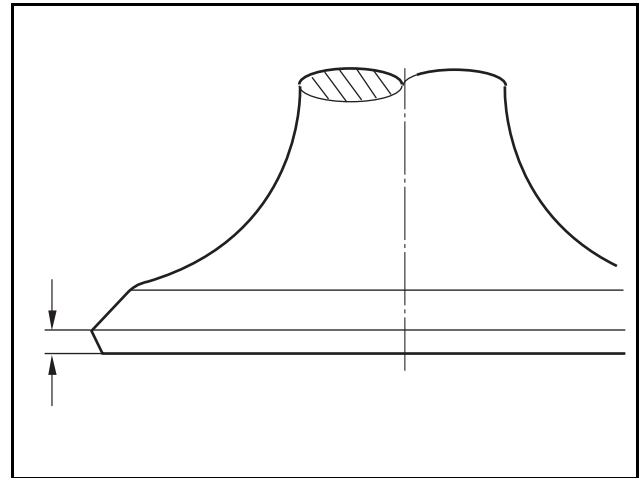

DV2213118A

Check of Valve Guide

1. Insert the valve into valve guide and measure the clearance between valve and valve guide by the shaking degree of valve. If the clearance is bigger, measure the valve and then replace the more worn valve guide.

Item	Standard	Limit
In.	0.020 ~ 0.049mm	0.20mm
Ex.	0.045 ~ 0.074mm	0.25mm

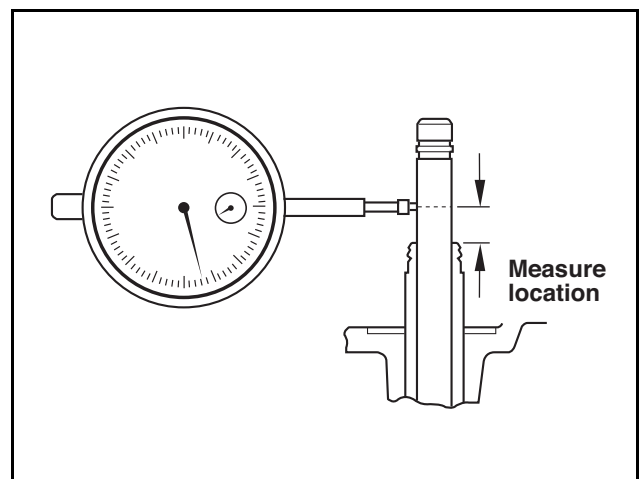

DV2213119A_E

2. If the valve guide has already been replaced, measure the center with valve seat if it deviates or not and if abnormal it must be corrected.

Note) Simultaneously be processed when in guide reamer process.

10. Cylinder block/head

Valve Seat

1. Visual inspection: Inspect the damage and wear of valve seat and if necessary replace.
2. Valve seat thickness and angle: Assemble the valves at the cylinder head and using the measuring instrument from the lower face, measure the projection amount of valve. If the measured value is more than the use limit, replace the valve seat.

Item	Standard	Limit
Valve seat thickness (at cylinder head surface)	0.65 ~ 0.95mm	2.5mm

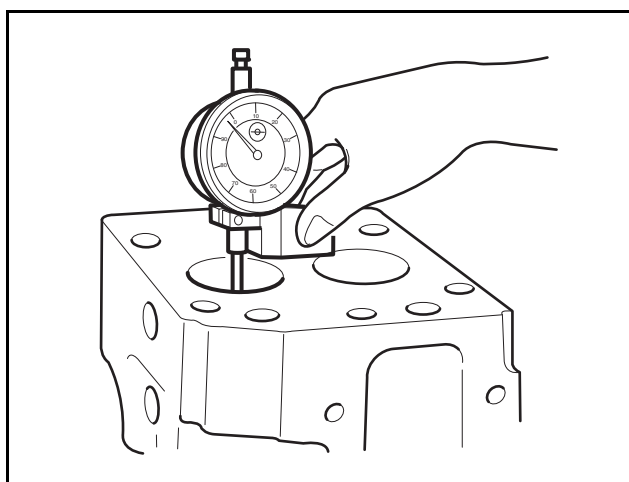

DV2213120A

Item	Limit	
Valve seat angle	In. Valve	30°
	Ex. Valve	45°

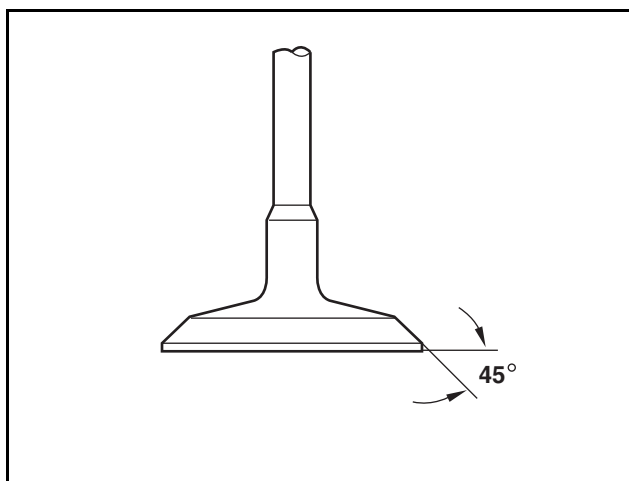

DV2213121A

3. The disassembly of valve seat can be pulled out by means of a special tool with the arc welding done at two points of valve seat rotating tool or valve seat.

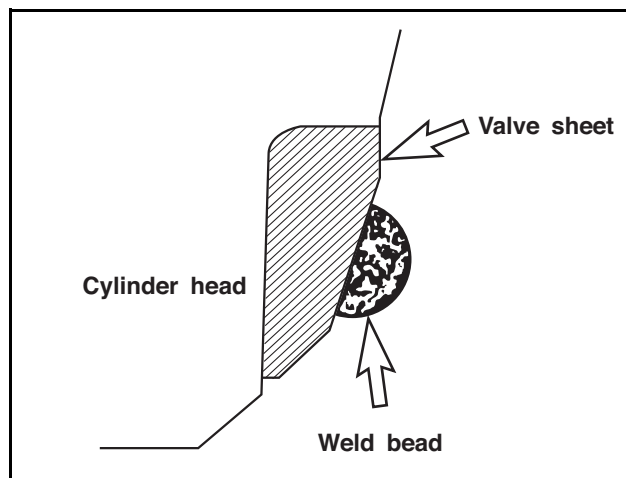

DV2213122A_E

4. Regarding the valve seat assembling, shrink the valve seat by putting it in the dry ices for about 1 hour or so, and then press it into the cylinder head by means of a special tool.
5. After coating the grinding powder paste on valve head contacting face of valve seat, and after executing a sufficient lapping operation with the rotating and grinding motion of valve, wipe off the grinding agent thoroughly.

Valve Spring

1. Visual inspection: Check if the exterior of the valve spring is damaged with the naked eye. Replace it with a new one if required.
2. Free length of valve spring: Measure the free length of the valve spring with the vernier calipers. If the reading is larger than the specified valve, replace the valve spring.

Item	Limit	
Free length of valve spring	Inside	65.5mm
	Outside	64mm

10. Cylinder block/head

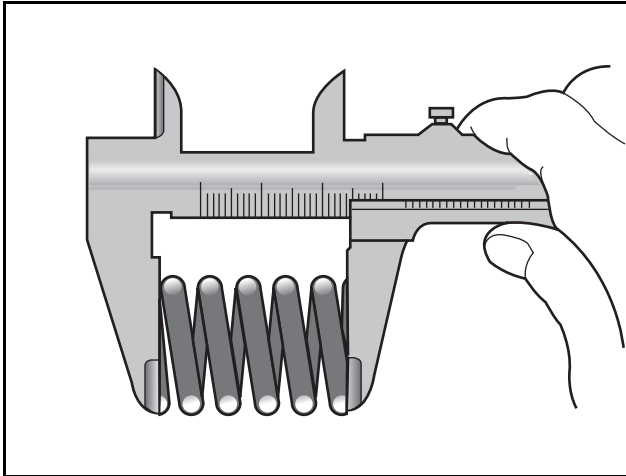

DV2213123A

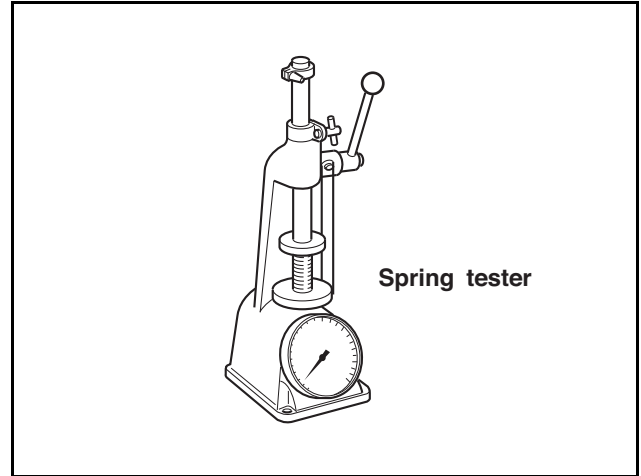

DV2213125A_E

3. Squareness of valve spring: Measure the squareness of the valve spring with the surface plate and the right-angle square. If the reading exceeds the tolerance limit, replace the valve spring.

Item	Standard
Squareness of valve spring	Below 1.0mm

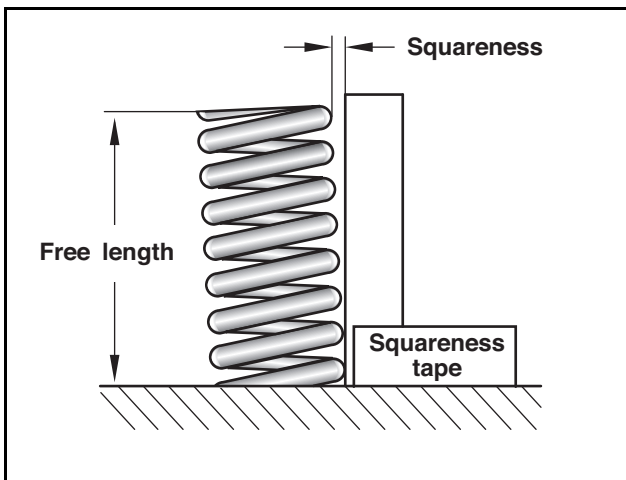

DV2213124A_E

4. Tension of valve spring: Measure the tension of a valve spring by using a spring tester. If the reading is below the tolerance limit, replace the valve spring.

Item		Standard
Inside	at weight condition 15~17kg	46.3mm
Outside	at weight condition 37~41kg	46.3mm

Rocker arm

Disassembly Rocker Arm

1. Remove the snap ring on both sides of the rocker arm shaft using snap ring plier.
2. Remove the washer and rocker arm.
3. Remove the rocker arm bush using press.

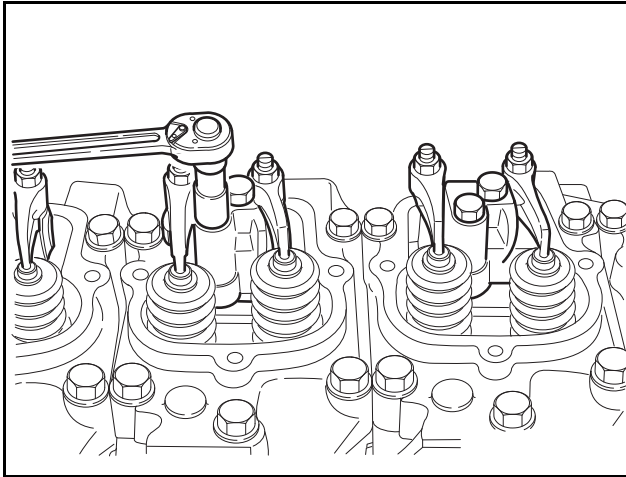

DV2213126A

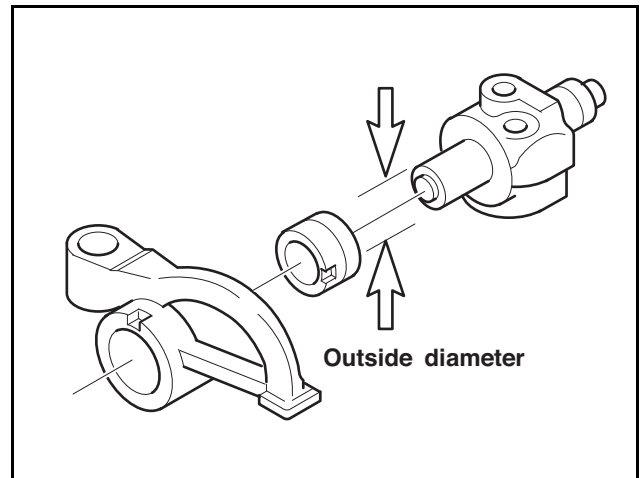

DV2213127A_E

2. Rocker arm: Inspect the rocker arm surface that contacts with the valve stem for any scratch, step wear and correct the minor degree of wear with an oil stone or the fine grinding paper and replace if they are severe.

Assembly Rocker Arm

1. Check if there is foreign substance in the oil delivery hole of the rocker arm shaft, and clean it, if any.
2. Attach the rocker arm in the reverse order of assembly.

⚠ CAUTION

Be careful not to change the rocker arm position or assemble it in a reverse order.

Check of Rocker Arm

1. Rocker arm bracket (Single unit type with a shaft):
Measure the outer diameter of rocker arm bracket with outside micrometer at the position that the rocker arm is installed, and in case that it exceeds the limit value, replace.

Item	Standard	Limit
Bush Inner Dia.	Ø25.005 ~ Ø25.035	Ø25.055
Shaft Outer Dia.	Ø24.967 ~ Ø24.990	Ø24.837
Clearance	0.015 ~ 0.068mm	0.25mm

⚠ CAUTION

If the wear is severe, replace new one.

10. Cylinder block/head

Tappet and push rod

Tappet Clearance

Measure the outer diameter of a tappet and the inner diameter of the tappet bore. If the reading exceeds the tolerance limit, replace the tappet.

Standard	Limit
0.035mm ~ 0.077mm	0.25mm

Visual inspection of tappet

Inspection if the tappet surface which contacts the camshaft has damage like crack or scratch. If the damage is small, correct it with oil stone or fine grinding paper, if excessive, replace it.

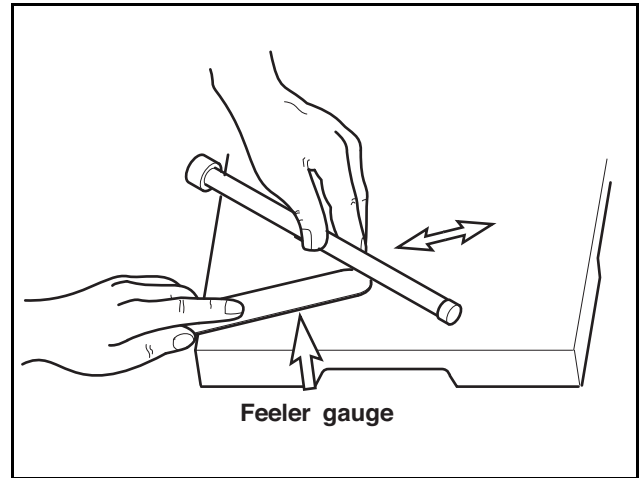

DV2213129A_E

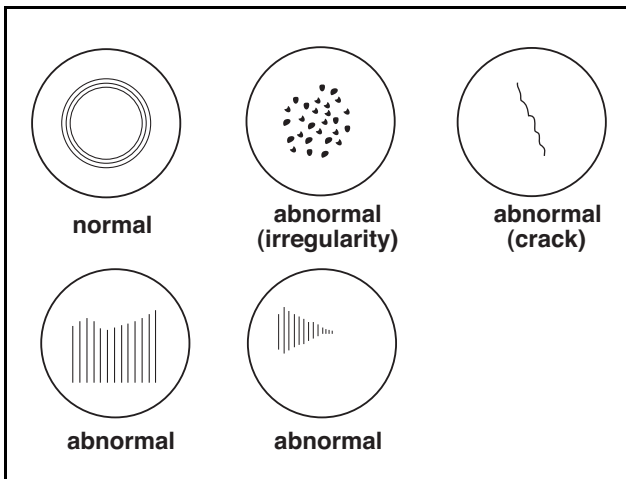

DV2213128A_E

Warpage of Push Rod

Put the push rod on a surface plate, and measure the warpage with a feeler gauge while spinning it. If the reading exceeds the tolerance limit, replace it.

Limit	Below 0.3mm
-------	-------------

Camshaft

Camshaft End Play

Measure the camshaft's axial end play.

1. Push the camshaft toward the pulley side.
2. Place a dial gauge onto the camshaft gear.

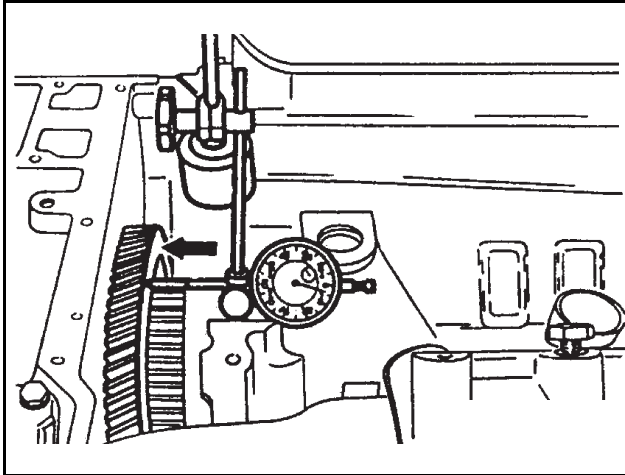

DV2213130A

3. Measure the camshaft's axial end play, moving the camshaft gear by means of driver.

Limit	Below 0.2 ~ 0.9mm
-------	-------------------

4. If excessive end play, assembly it by means of other thrust washer.

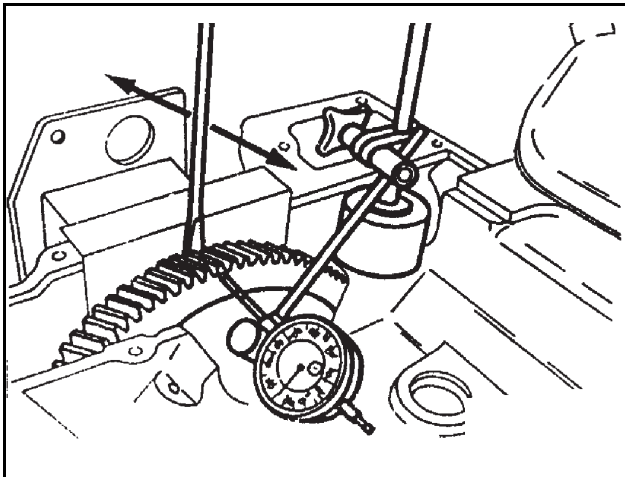

DV2213131A

Check of Cam

1. Visual check: With inspecting the cam surface for any damage with naked eyes and correct any minor scratches by means of an oil stone grinding and if severe, replace it.

2. Cam lobe height: Use a micrometer to measure the cam lobe height and journal diameter. If the measured number is less than the specified limit, the camshaft must be replaced.

Item	Standard	Limit
Cam lobe height(C)	47.7mm	46.5mm
Cam bearing outside (A,B)	Ø56.0mm	Ø55.6mm

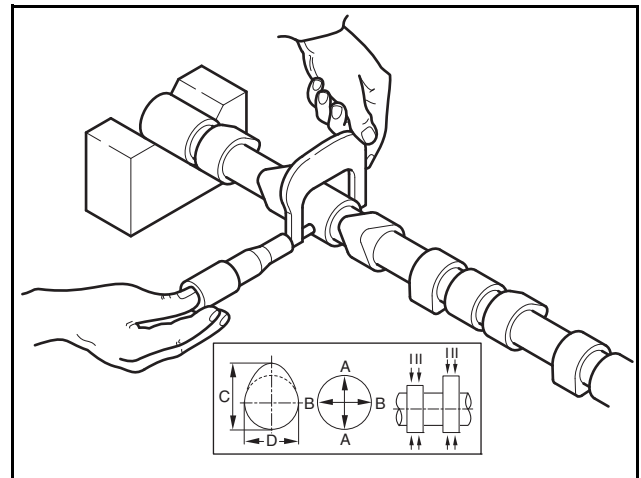

DV2213132A

Check of camshaft

1. Camshaft bearing outer diameter: Using an outer diameter micrometer, measure the outer diameter of the camshaft bearing.

Item	Standard
Camshaft bearing outer diameter	Ø69.91 ~ Ø69.94mm

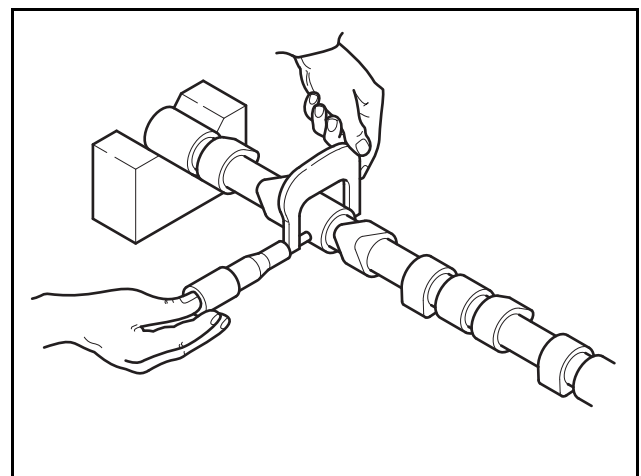

DV2213133A

10. Cylinder block/head

2. Camshaft bearing inner diameter of cylinder block:
Using a cylinder inner gauge, measure the inner diameter of the camshaft bearing.

Item	Standard
Camshaft bearing inner diameter of cylinder block	$\varnothing 70.077 \sim \varnothing 70.061\text{mm}$

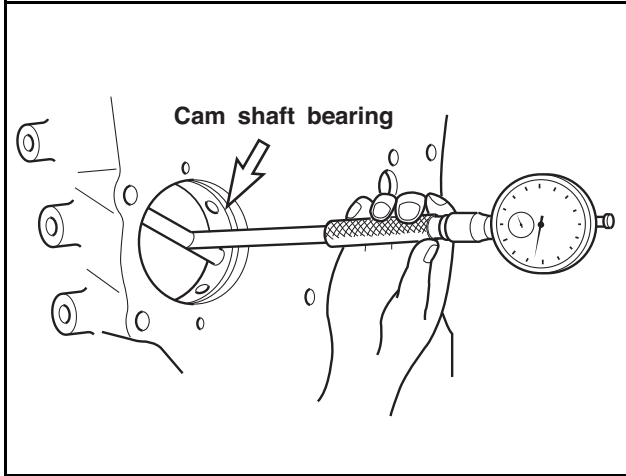

DV2213134A_E

3. Clearance between camshaft and bearing: Compare the inner diameter of the camshaft bearing with the outer diameter value of the camshaft to determine the clearance. If the reading exceeds the tolerance limit, replace the camshaft bearing.

Item	Limit
Clearance between camshaft and bearing	0.18mm

4. Camshaft bearing replacement: Replace the camshaft bearing with a special tool.

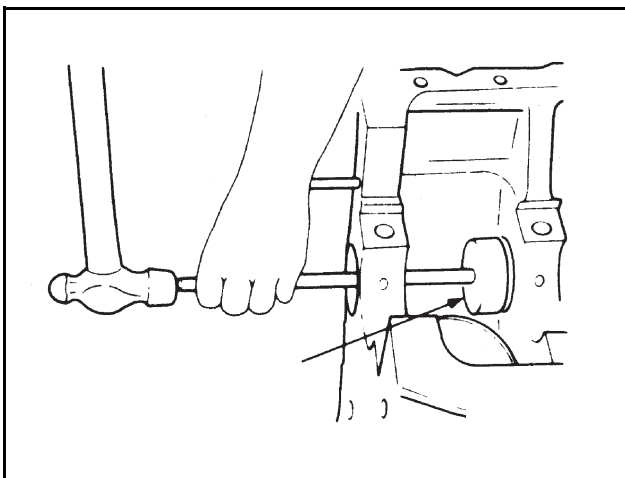

DV2213135A

5. Warpage of camshaft: Place the camshaft on 2 V blocks, and inspect the warpage of the camshaft by using a dial gauge to correct it. if excessive, replace the camshaft.

Item	Limit
Warpage of camshaft	0.1mm

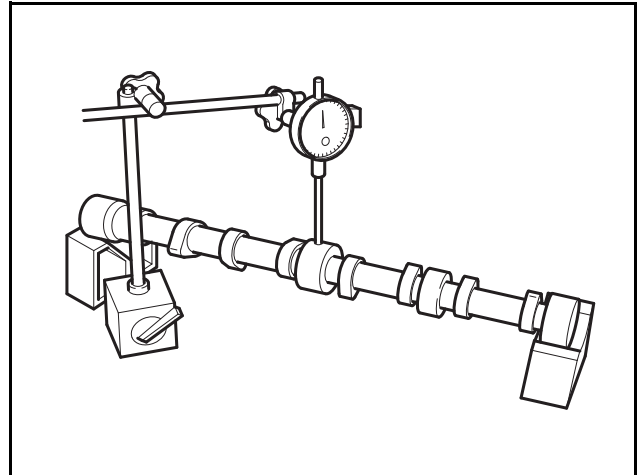

DV2213136A

11. Electric system

General information	183
Specification.	183
Electrical Wiring diagram.	184
Switches and sensors	185
Temperature Switch	185
Temperature Sensor	185
Pressure Sensor & Switch	185
Magnetic Pick-up	186
Starter	187
General Information	187
Specification.	187
Views	188
Wiring Diagram	189
Resistance	189
Alternator	190
General Information	190
Views	190
Wiring Diagram	191
Specification.	191
Performance.	191
Abnormally Charging.	191

General information

Specification

Item	DP158L				Remarks
	DP158LCS	DP158LCF	DP158LDS	DP158LDF10	
Electrical System					
Alternator voltage - capacity (V - A)	27.5 - 45				
Voltage regulator	Built-in type IC regulator				
Starting motor voltage - capacity (V - kW)	24 - 7.0				
Battery capacity	2-200Ah (recommended)				

Item	DP180L				Remarks
	DP180LBS	DP180LBF	DP180LAS	DP180LAF	
Electrical System					
Alternator voltage - capacity (V - A)	27.5 - 45				
Voltage regulator	Built-in type IC regulator				
Starting motor voltage - capacity (V - kW)	24 - 7.0				
Battery capacity	2-200Ah (recommended)				

Item	DP222L					Remarks
	DP222LAS	DP222LBS	DP222LBF	DP222LCS	DP222LCF	
Electrical System						
Alternator voltage - capacity (V - A)	27.5 - 45					
Voltage regulator	Built-in type IC regulator					
Starting motor voltage - capacity (V - kW)	24 - 7.0					
Battery capacity	2-200Ah (recommended)					

11. Electric system

Electrical Wiring diagram

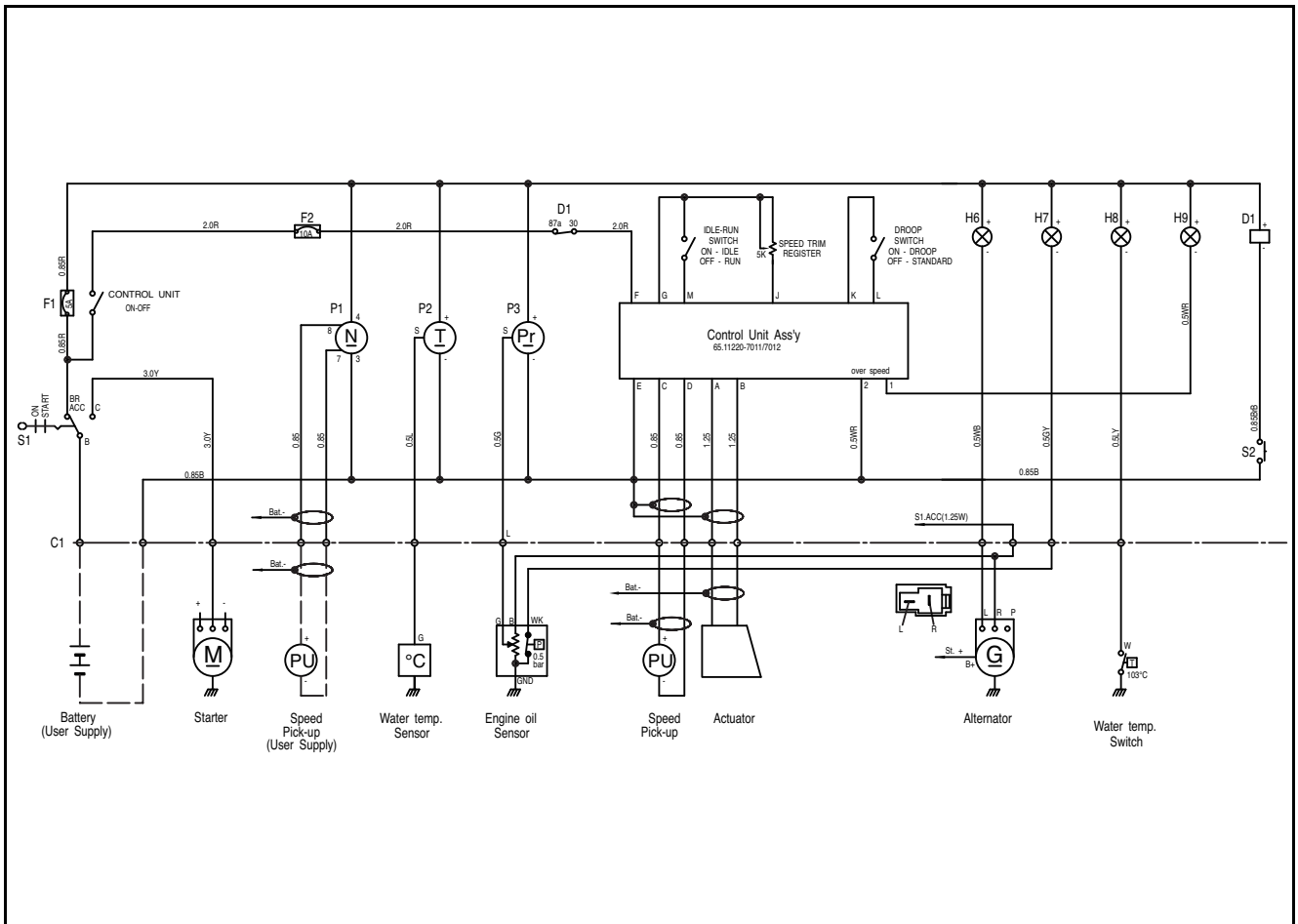

DV2213212A

Switches and sensors

Temperature Switch

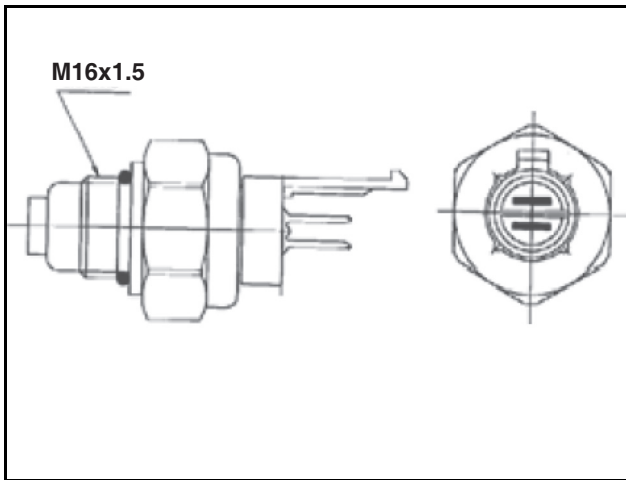

DV2213141A

Operation Temperature	ON: 103°C ± 3°C, OFF: 96°C
Current Capacity	DC12V, 9A
TYPE	Normal Open
Insulation Resistance	more than 10MΩ

Temperature Sensor

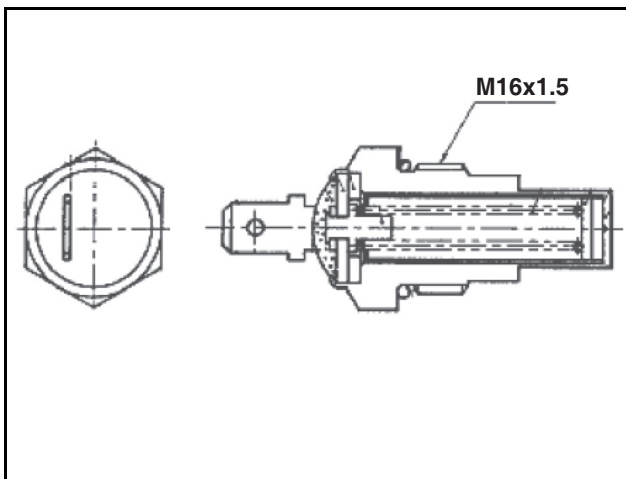

DV2213142A

Temperature (°C)	50	80	100	120
Resistance (Ω)	153.9	47.5~58.0	26.2~31.3	16.1

Pressure Sensor & Switch

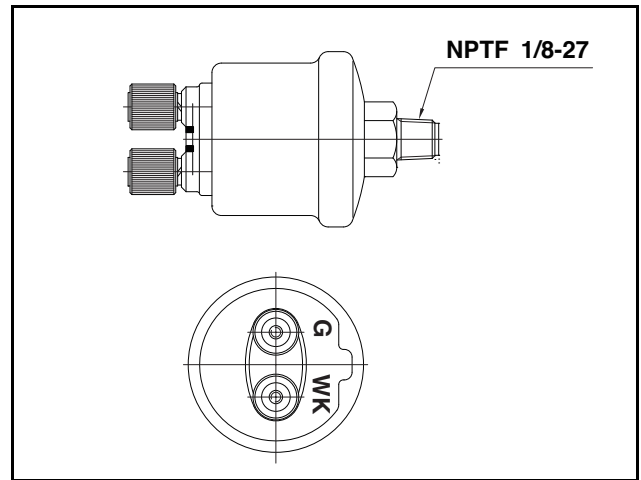

DV2213143B

1. Output characteristic

Pressure (bar)	Resistance (Ω)
0	$10^{-5} \sim 10^{+3}$
(1.5)	31 ± 4
2	52 ± 4
(3)	70 ± 4
4	88 ± 4
(5)	106 ± 5
6	124 ± 5
(7)	140 ± 10
(8)	$155_{-10} \sim 155^{+15}$
(9)	170 ± 25
(10)	184 ± 30

2. Warning output: switch(WK) to GND at 0.5bar ± 0.2bar

3. Max. pressure: 30 bar (momentary 2sec)

4. Operating temperature: -30°C ~ 100°C (Max. 120°C, 1h)

11. Electric system

Magnetic Pick-up

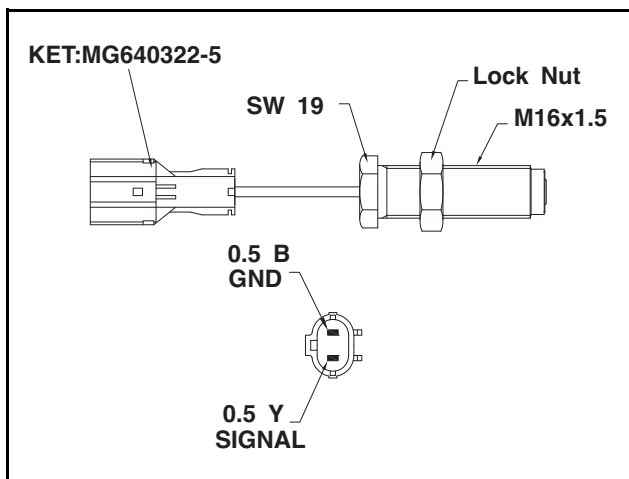

DV2213146B

1. Operating temperature: $-40^{\circ}\text{C} \sim 120^{\circ}\text{C}$
2. Output Volt (P-P)

	above 14V	above 7V
Gear	Module M=3, Teeth Z=32	M=3, Z=32
Clearance	$1.0 \pm 0.1\text{mm}$	$1.0 \pm 0.1\text{mm}$
Revolution	$1,000 \pm 20 \text{ RPM}$	$1,000 \pm 20 \text{ RPM}$
Load	Open	$5\text{k}\Omega$ Resistive

3. DC resistance: $1.8\text{k}\Omega \pm 15\%$
4. Inductance: $3.1\text{H} \pm 25\%$
5. Insulation Resistance: $10\text{M}\Omega$ or more at 500V DC
6. Resistance (B ~ Y): $350\Omega \pm 10\%$

Starter

General Information

The starter is attached to the back of the flywheel housing. When disassembling the engine, immerse the pinion gear and ring gear of the starter in fuel, brush them, and then apply greases to them in order to prevent rust.

Specification

CAUTION

- **Starter should be protected from humidity all the time.**
- **Before working on the electric system, be sure to disconnect the ground wire("-" minus wire) of the battery. Short circuit may occur while working on the electrical system. Connect the ground wire last after completing all of work.**

Specification		
NOMINAL OUTPUT		24V, 7.0kW
ENGAGEMENT SYSTEM		AUXILIARY ROTATION SYSTEM/SOFT START
Max. RATED TIME		30 SEC
ROTATION		CLOCKWISE VIEWED FROM THE PINION
SWITCH HOLD-IN CURRENT	MAGNETIC SWITCH	2.3A
	SOLENOID SWITCH	15A

11. Electric system

Views

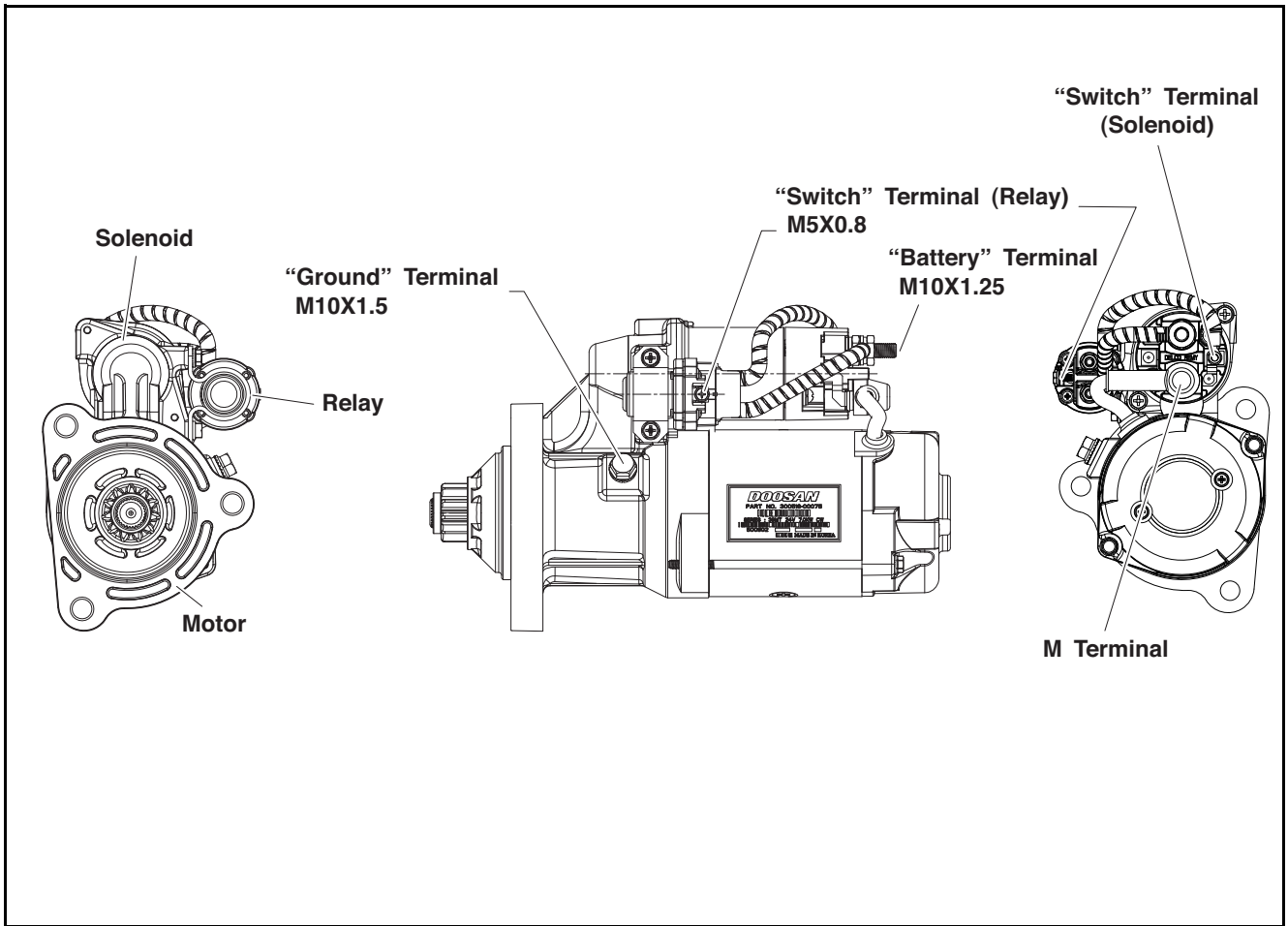

DV2213139A

Wiring Diagram

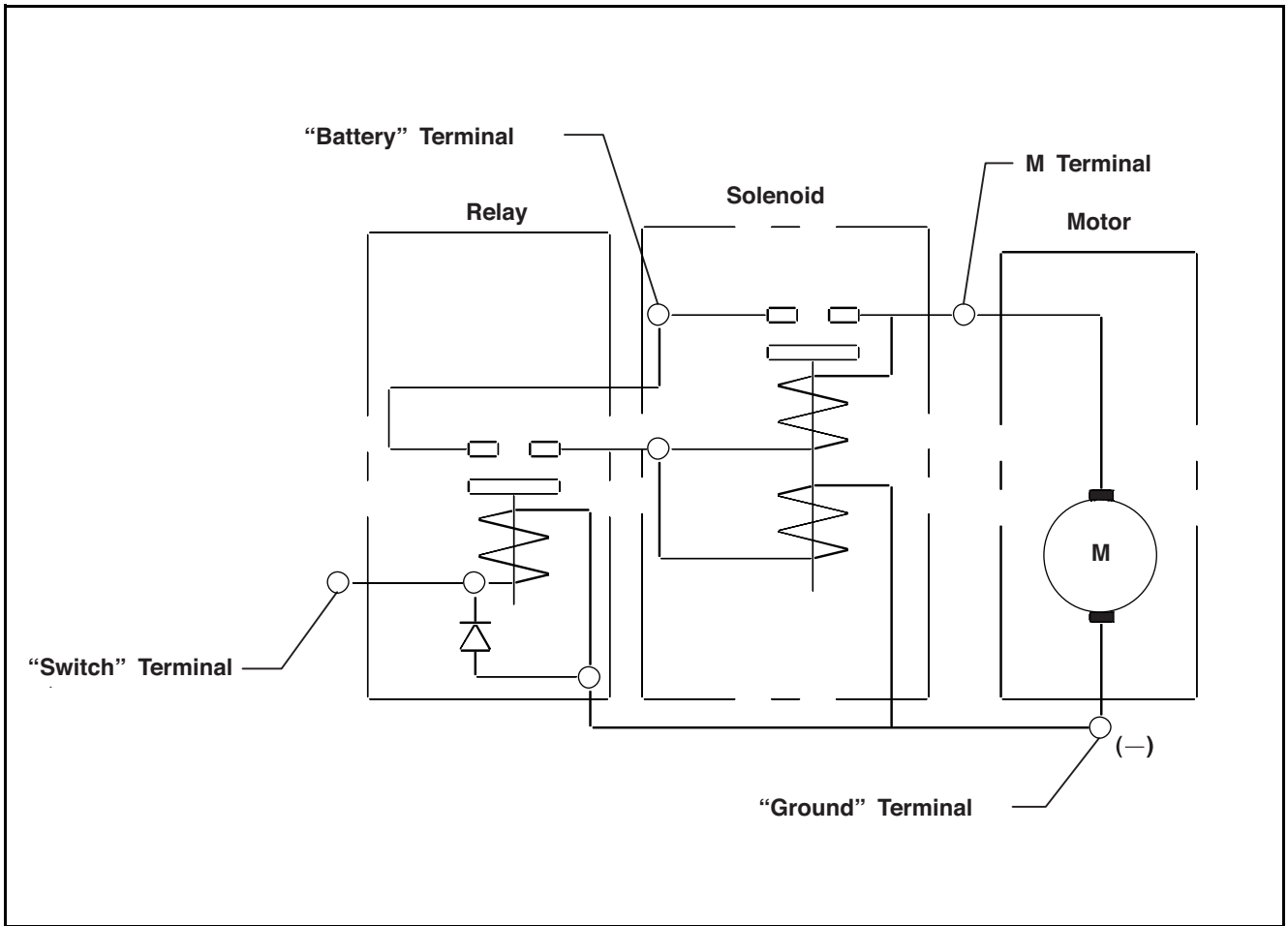

DV2213140A

Resistance

Item	+	-	Spec.
Relay	Switch Terminal	Relay Case	23.5kΩ ± 2.35
Solenoid	Switch Terminal	M Terminal	0.124Ω ± 5%

11. Electric system

Alternator

General Information

The alternator is fitted with integral silicon rectifiers. A transistorized regulator mounted on the alternator body interior limits the alternator voltage. The alternator should not be operated except with the regulator and battery connected in circuit to avoid damage to the rectifier and regulator. The alternator is maintenance-free, nevertheless, it must be protected against dust and, above all, against moisture and water.

Views

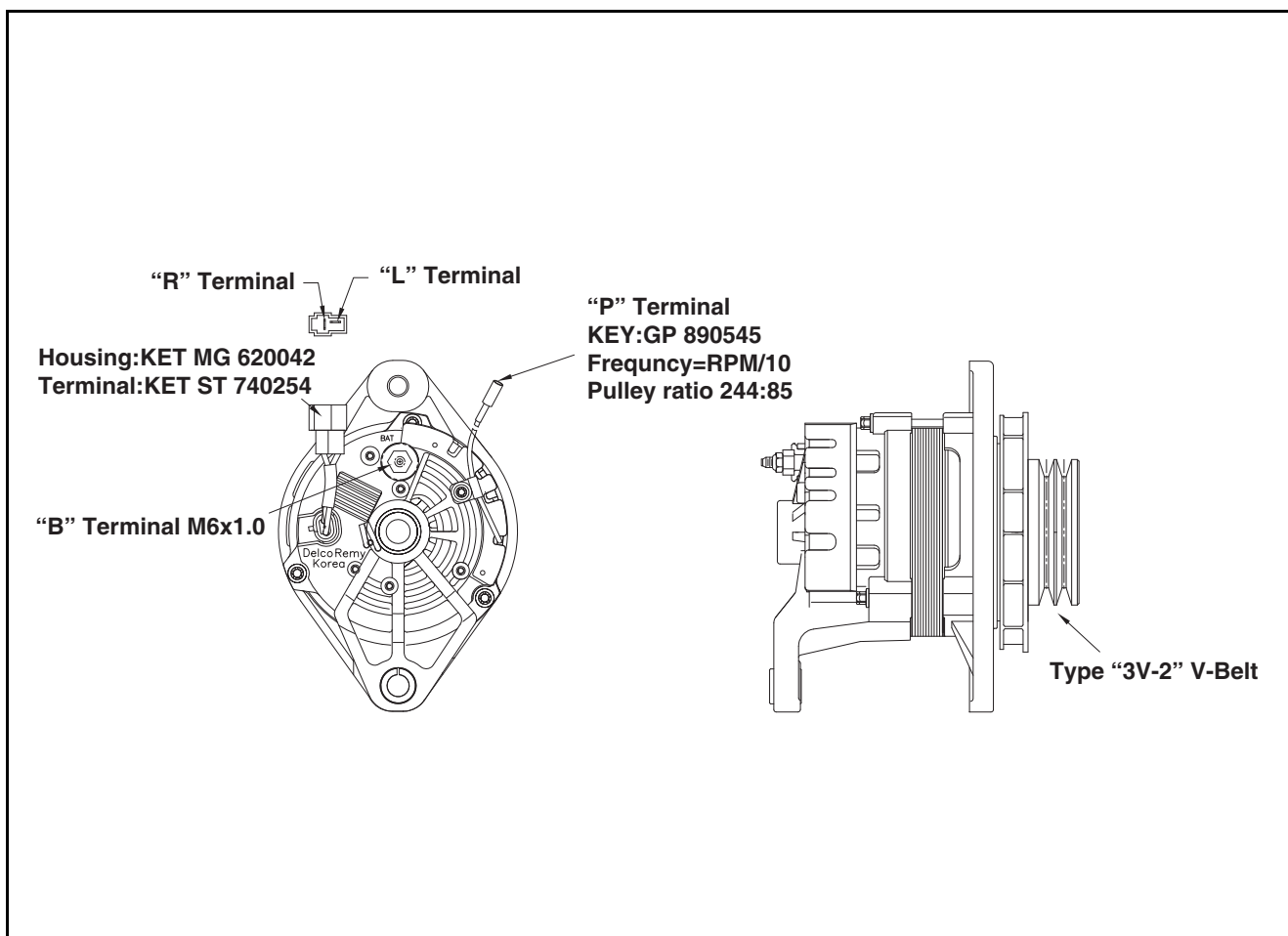

DV2213137A

Wiring Diagram

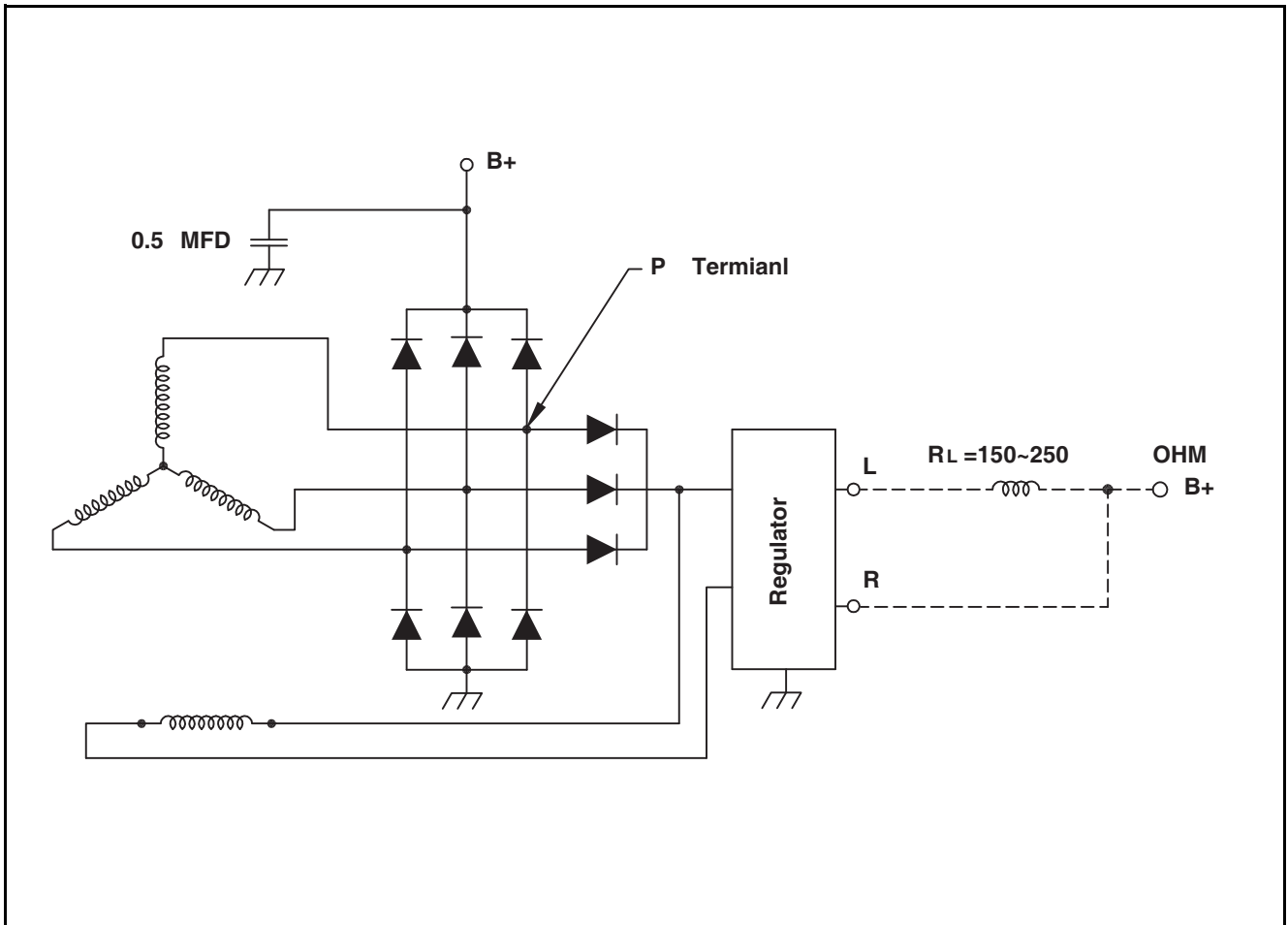

DV2213138A

Specification

Specification		
RATING	Continuous rating	
ROTATION DIRECTION	Clockwise	
BATTERY VOLTAGE	24V	
TURN ON RPM	Max. 1,050 RPM	
SPEED IN USE	1,000 ~ 8,000 RPM	
MAX. INLET AIR TEMP	105°C	
POLARITY	SET.VOLT.	27.5V
	TEMP.GRAD	10±3mV/°C

Performance

Performance			
Voltage (V)	Output current (A)		Speed (RPM)
	COLD	HOT	
27.5V	(22)	17.5	1,800
	(48)	45	5,000

Abnormally Charging

1. Measuring the voltage between the terminal and the alternator body when operating.

Note) Measuring the voltage in order to check the wire condition needs only the terminal when the engine is stopped.

1) During operation

11. Electric system

Position	Voltage
Terminal B - Body	About DC27V ~ 29.5V
Terminal L - Body	About DC27V ~ 29.5V
Terminal R - Body	About DC3V ~ 5V

2) During Stop

Position	Voltage
Terminal B - Body	About DC22V ~ 27V
Terminal L - Body	About DC22V ~ 27V
Terminal R - Body	0

2. Check of a voltage regulators: Mearsuring the resistance between the terminals.

1) The resistance value between the voltage regulators.

Terminal		Resistance
+	-	
L	Body	4 ~ 4.5 k Ω
R	Body	110 ~ 180 k Ω
Body	R	110 ~ 180 k Ω
L	R	110 ~ 180 k Ω

12. Others/driving system

General information	195
General Information	195
Crankshaft	196
Measurement of Crankshaft	196
Measurement of Crankshaft Bearing and Connecting Rod Bearing	197
Piston	199
Disassembly of Piston	199
Assembly of Piston.	199
Piston Inspection	199
Piston Ring and Ring Groove	200
Piston pin	200
Connecting rod.	202
Inspecting the connecting rod	202
Others	203
Engine Timing	203

General information

General Information

The forged crankshaft has screwed-on dounterweights. Radial seals with replaceable wearing rings on crankshaft and flywheel are provided to seal the crankcase penetrations.

The connecting rods are die-forged, diagonally split and can be removed through the top of the cylinders together with the pistons. Crankshaft and connecting rods run in steel-backed lead bronze ready-to-fit bearings.

12. Others/driving system

Crankshaft

Measurement of Crankshaft

1. Inspection and measurement
 - 1) Visually inspect whether there is any crack or scratch on the journal and pins of the crankshaft.
 - 2) Perform the magnetic particle testing or the liquid penetrant testing (color check) to check the cracks on the crankshaft. If cracks are found, replace the crankshaft with a new one.
2. Measuring journal and pin diameter
 - 1) Using an outer diameter micrometer, measure the crankshaft journals and pins toward the direction as shown in the figure to determine the amount of wear.

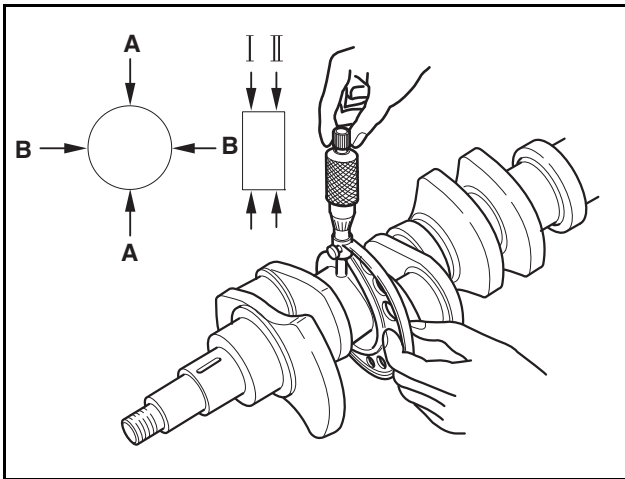

DV2213147A

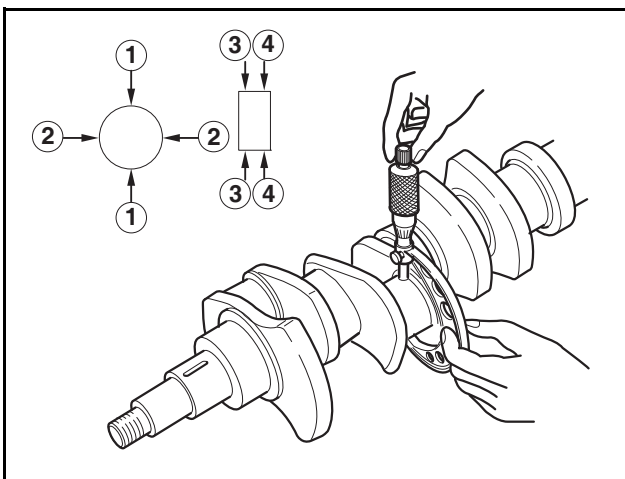

DV2213148A

- 2) If the amount of wear exceeds the tolerance limit, grind the crankshaft and assemble an under-size bearing.
- 3) There are 4 kinds as below, and the crankshaft also can be used by regrinding as below.
 - Standard
 - 0.25 (Inside diameter 0.25 mm less than standard)
 - 0.50 (Inside diameter 0.50 mm less than standard)
 - 0.75 (Inside diameter 0.75 mm less than standard)
 - 1.00 (Inside diameter 1.00 mm less than standard)
- 4) "R" part standard value
 - Crank pin "R": 3.5 ~ 4.0
 - Crank journal "R": 3.5 ~ 4.0

CAUTION

In case of crankshaft regrinding, the "R" part at the end of bearing must accurately be ground without fail and should avoid any processed jaw or coarse surface.

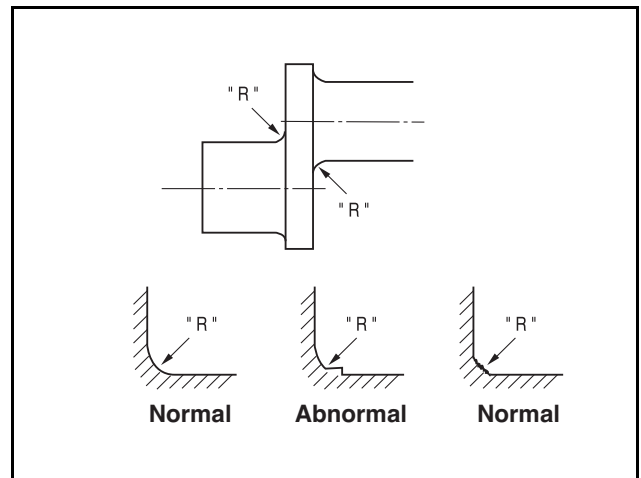

DV2213149A_E

3. Warpage of crankshaft
 - 1) Put the crankshaft on the V block.
 - 2) Put the dial gauge on the surface plate and measure the warpage of the crankshaft as spinning the crankshaft.

Item	Standard
Crankshaft journal's outer diameter	Ø103.98 ~ Ø104.00mm
Crankshaft pin's outer diameter	Ø89.98 ~ Ø90.00mm

12. Others/driving system

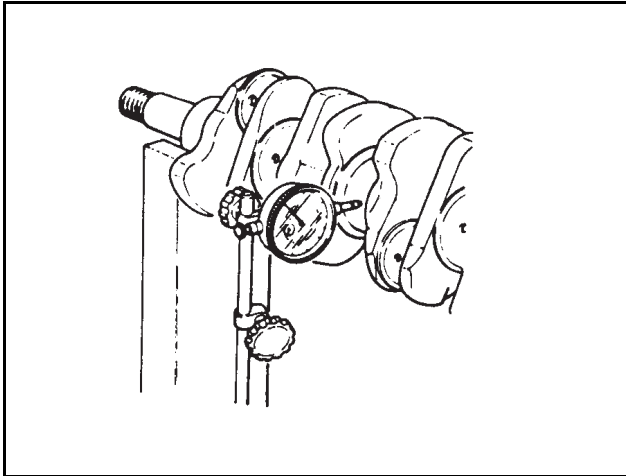

DV2213150A

Item	Standard	Limit
Warpage of crankshaft	0.06mm	0.4mm

Measurement of Crankshaft Bearing and Connecting Rod Bearing

1. Visual inspection

Visually inspect the crankshaft bearing and connecting rod bearing for scratch, unusual wear or damage.

2. Oil clearance between crankshaft and bearing (Method 1: Dial gauge)

- 1) Assemble the main bearing to the cylinder block, tighten the bearing cap to the specified torque.

Item	Standard
Tightening torque	First 30 kgf·m + 90°

2) Measure the inner diameter.

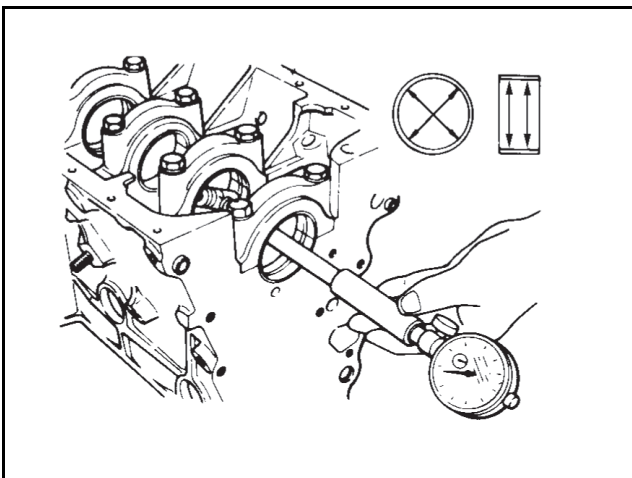

DV2213151A

Item	Standard
Journal's inner diameter	Ø104mm

- 3) Assemble the bearing to the connecting rod, tighten the bearing cap to the specified torque.

Item	Standard
Tightening torque	First 30 kgf·m + 90°

- 4) Measure the connecting rod bearing journal inner diameter.

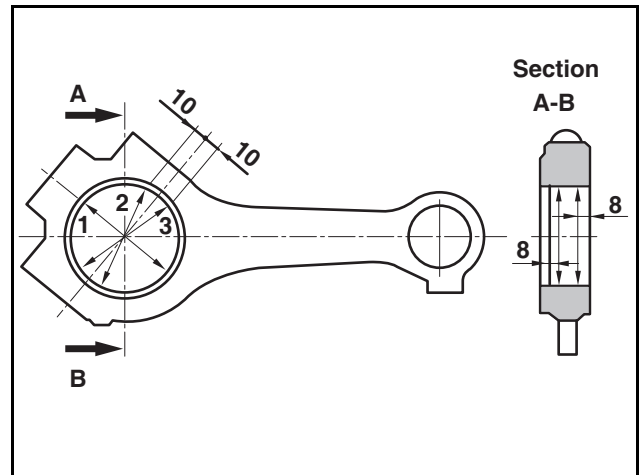

DV2213152A

Item	Standard
Inner diameter	Ø90.00

- 5) if the clearance exceeds the tolerance limit, grind the crankshaft journal and pin, and assemble under size bearing.

Item	Standard	Limit
Clearance	0.066~0.132mm	0.166mm

3. Oil clearance between crankshaft and bearing. (Method 2: Plastic gauge)

- 1) Assemble the crankshaft to the cylinder block.
- 2) Place the plastic gauge on the crankshaft journal and pan.
- 3) Assemble the bearing cap and tighten the bolt to the specified torque.
- 4) Loosen the bolt, remove the bearing cap.
- 5) Measure the width of the plastic gauge at the widest point using the ruler for plastic gauge measurement. This is the oil clearance.
- 6) Measure the oil clearance of connecting rod as the same procedure.

4. End play

- 1) Assemble the crankshaft in the cylinder block.
- 2) Install the dial gauge, and measure the end play of crankshaft by pushing the crankshaft to axial direction.

12. Others/driving system

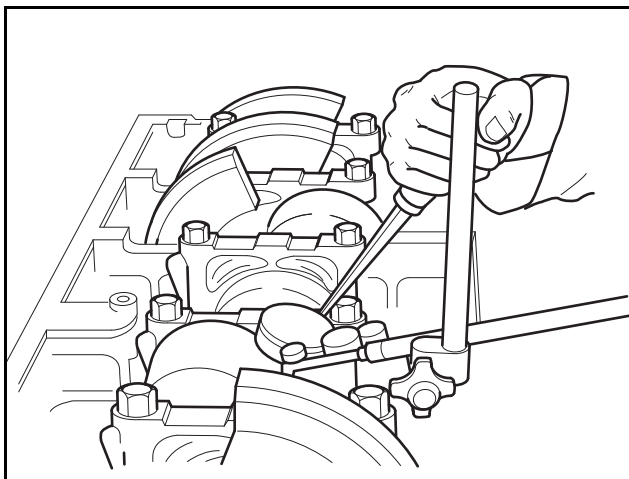

DV2213153A

Item	Standard	Limit
Axial end play	0.190~0.322mm	0.452mm

Piston

Disassembly of Piston

1. Pull out the snap ring for piston pin and with a pair of snap ring pliers.

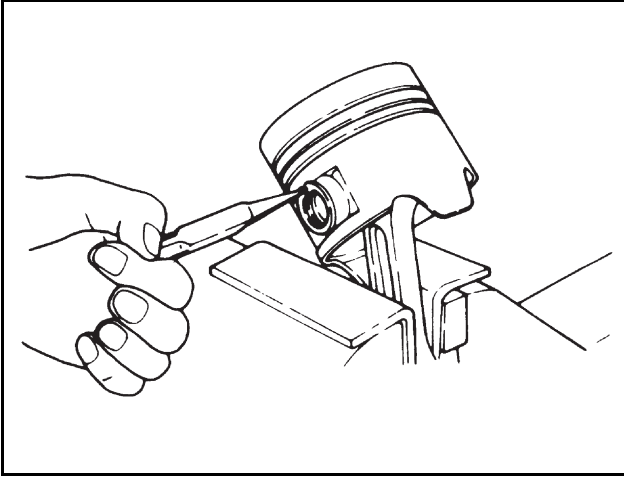

DV2213154A

2. With a round bar, remove the piston pin.
3. With a pair of pliers, remove the piston rings.

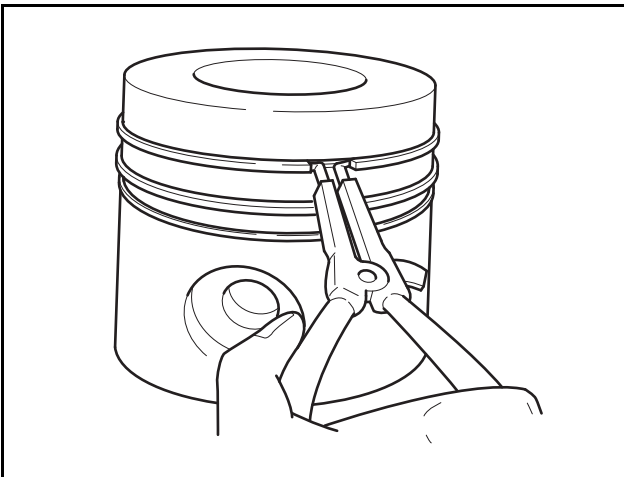

DV2213155A

4. Clean the piston thoroughly.

Assembly of Piston

1. Heat the piston at the piston heater for about 5 minutes (120 ~ 150°C).

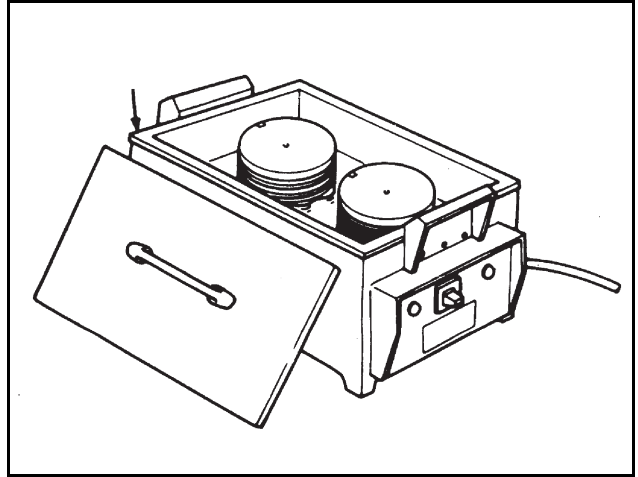

DV2213156A

2. By aligning the piston pin hole with the pin hole of connecting rod's smaller end, insert the oil coated piston pin.

⚠ CAUTION

Confirm the direction of connecting rod and assemble.

3. With the snap ring plier, insert the snap rings of the piston pin.
4. With confirming the upper side indication of piston ring, after assembling the ring in the piston ring groove, inspect if the movement of ring is smooth.

⚠ CAUTION

Arrange the assembled piston in order as the cylinder number.

Piston Inspection

1. Visual inspection
 - 1) Visually check the piston for crack, scratch, wear, etc. Specially, check the wear status of the ring groove.
2. Piston outside diameter inspection
 - 1) With the outside micrometer, measure the outside diameter.
 - 2) The measuring position is 71.5mm from the piston lower end, and the direction of measurement must be perpendicular to the piston pin direction.

12. Others/driving system

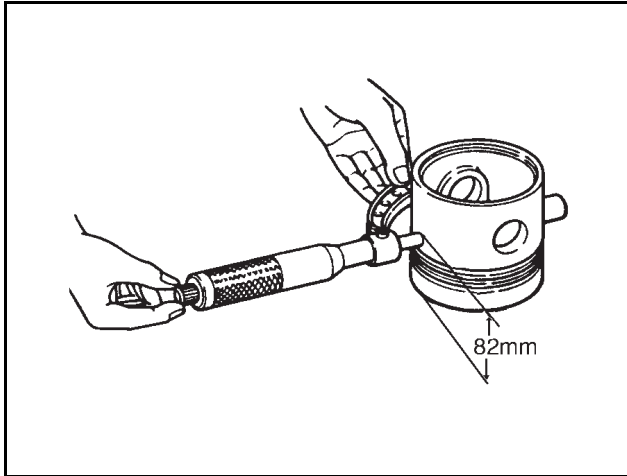

DV2213157A

Item	Standard
Piston outside diameter	Ø127.739~ Ø127.757mm

CAUTION

By comparing the measured value of the piston outside diameter with the cylinder liner inside diameter, the bigger clearance is replaced.

Piston Ring and Ring Groove

1. In case of piston ring's wear, damage or engine overhaul, replace piston rings.
2. Piston ring gap clearance: measure the piston ring cut part.
 - 1) Insert the piston ring at the cylinder liner's upper part perpendicular.
 - 2) With a feeler gauge, measure the gap clearance of piston ring.

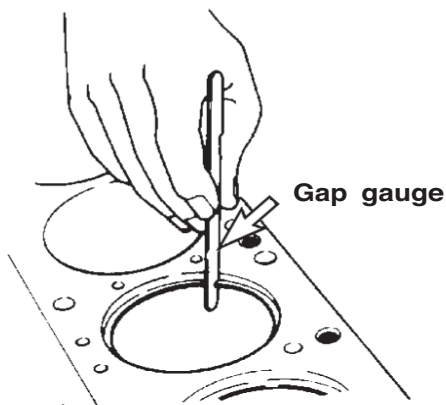

DV2213158A_E

- 3) If the measured value exceeds the limit value, replace it.

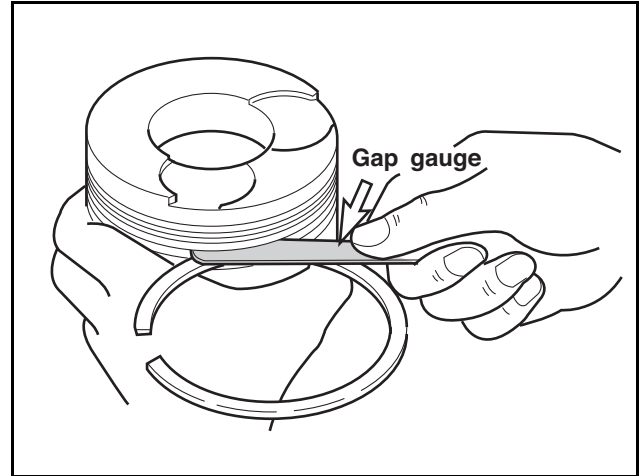

DV2213159A_E

Item	Standard	Limit
Top ring	0.35 ~ 0.55mm	1.5mm
2nd ring	0.50 ~ 0.82mm	1.5mm
Oil ring	0.30 ~ 0.62mm	1.5mm

Piston pin

1. Wear
 - 1) Measure the wear amount of the piston pin with a outside micrometer.
 - 2) If the reading exceeds the tolerance limit, replace the pin.

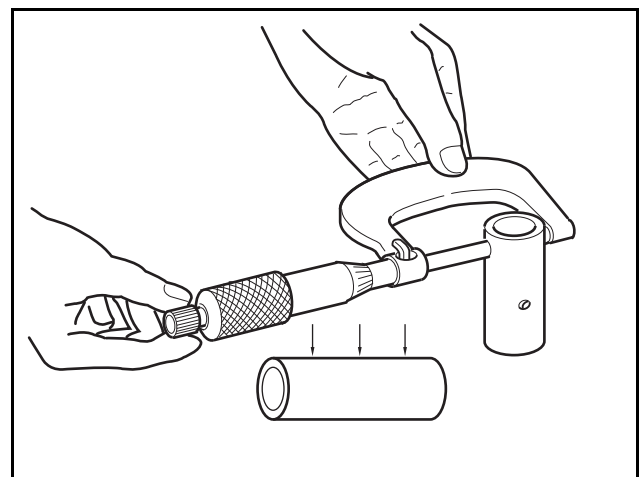

DV2213160A

Item	Standard	Limit
Outside diameter	Ø45.994~Ø46.000mm	Ø45.983mm

2. Clearance

- 1) Measure the clearance between the piston pin and connecting rod bush.

12. Others/driving system

- 2) If the reading exceeds the tolerance limit, replace the one which are worn more.

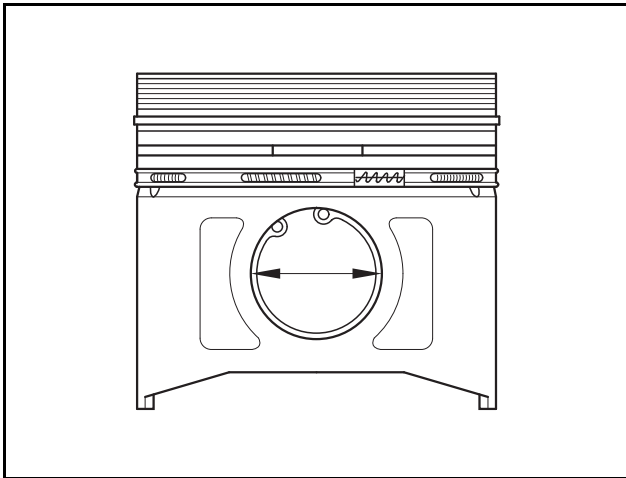

DV2213161A

Item	Standard
Clearance	0.003 ~ 0.015mm

12. Others/driving system

Connecting rod

Inspecting the connecting rod

1. Measure the parallelism between the connecting rod small end's bush hole and the large end bearing hole. Here, use both the connecting rod measuring device and feeler gauge.

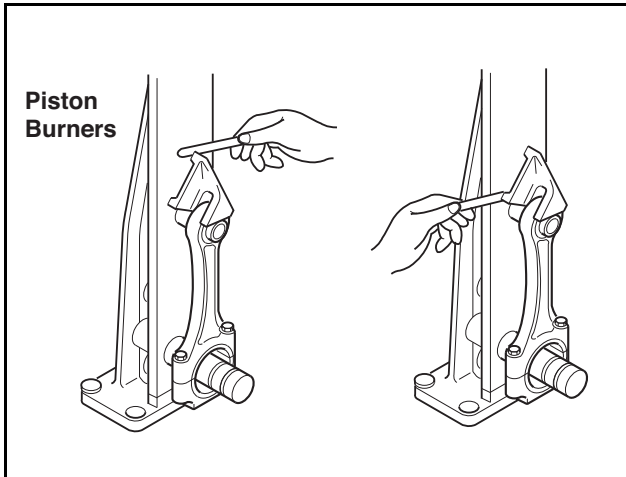

DV2213162A_E

Item	Standard	Limit
Degree of parallelization	0.02mm	0.2mm

Others

Engine Timing

1. Crankshaft gear
2. Oil pump drive gear
3. Oil pump impeller gears
4. Camshaft drive gear
5. Injection pump drive gear

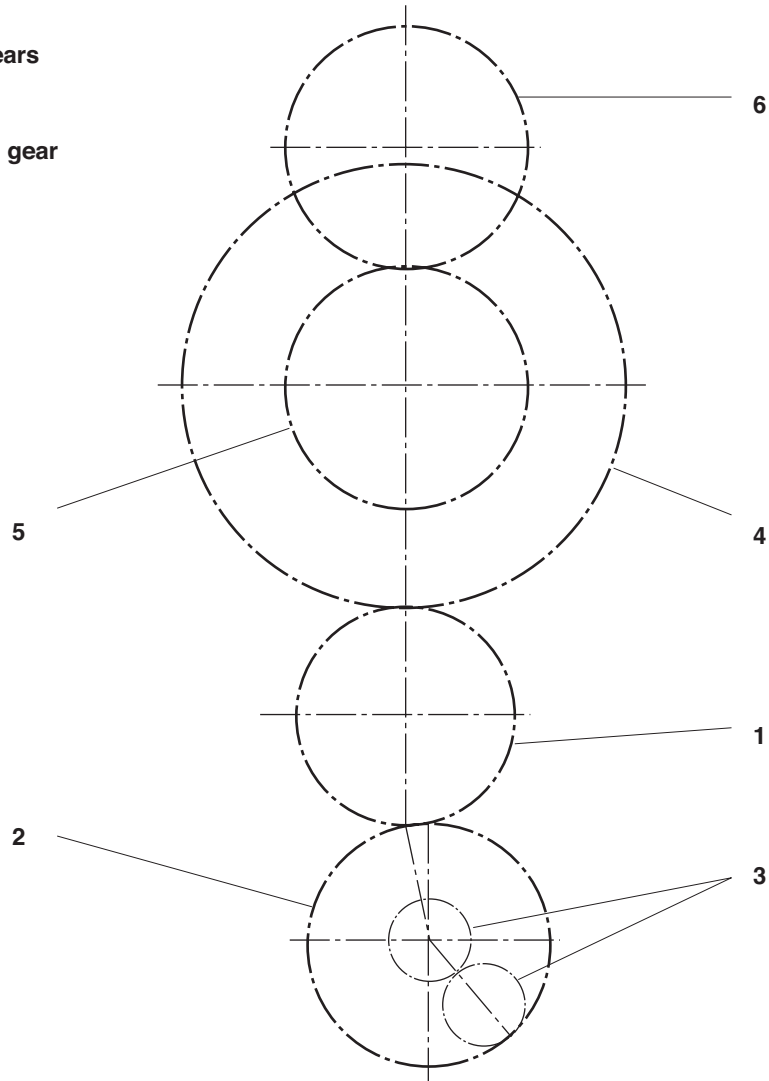

DV2213204A