

# VOLVO PENTA INDUSTRIAL DIESEL

# TAD734GE

250kW (340 hp) at 1500 rpm, 263 kW (357 hp) at 1800 rpm, acc. to ISO 3046

The TAD734GE is a powerful, reliable and economical Generating Set Diesel Engine built on the dependable in-line six design.

## Durability & low noise

Designed for easiest, fastest and most economical installation. Well-balanced to produce smooth and vibration-free operation with low noise level.

To maintain a controlled working temperature in cylinders and combustion chambers, the engine is equipped with piston cooling. The engine is also fitted with replaceable cylinder liners and valve seats/guides to ensure maximum durability and service life of the engine.

## Low exhaust emission

The state of the art, high-tech injection and charging system with low internal losses contributes to excellent combustion and low fuel consumption.

The TAD734GE complies with EU Stage 2 exhaust emission regulations.

## Easy service & maintenance

Easily accessible service and maintenance points contribute to the ease of service of the engine.

## Technical description

### Engine and block

- Optimized cast iron cylinder block with optimum distribution of forces
- Piston cooling for low piston temperature and reduced ring temperature
- Drop forged steel connecting rods
- Crankshaft hardened bearing surfaces and fillets for moderate load on main and big-end bearings
- Keystone top compression rings for long service life
- Replaceable valve guides and valve seats
- Three PTO positions at flywheel end
- Lift eyelets
- Flywheel housing with connection acc. to SAE 2
- Flywheel for flexplate
- Fixed integrated radiator front engine suspension
- Transport brackets, rear

### Lubrication system

- Full flow cartridge insert filter
- Rotary displacement oil pump driven by the crankshaft
- Deep front oil sump
- Oil filler on top
- Oil dipstick, short in front
- Integrated full flow oil cooler, side-mounted

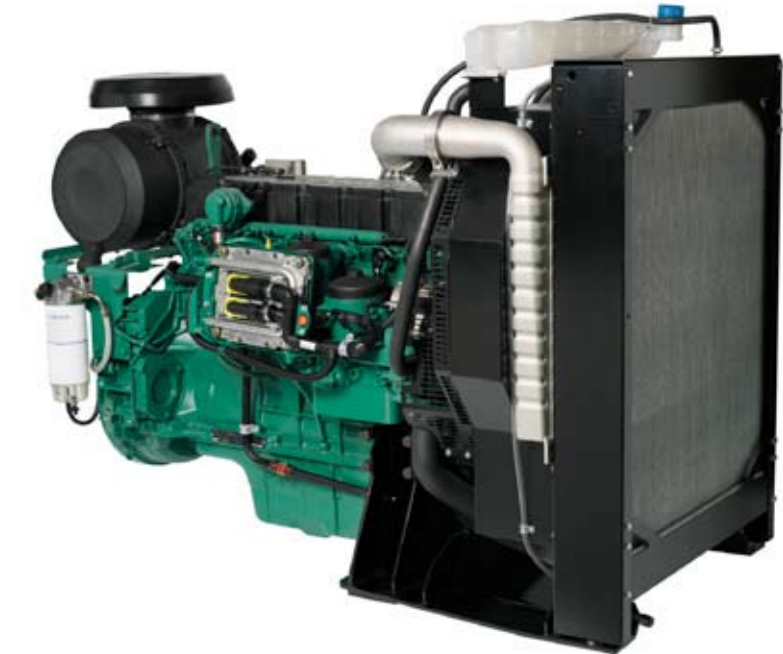

## Features

- Electronic governing, EMS2
- CAN bus communication
- Compact design for the power class
- High power to weight ratio
- Emission compliant
- Noise optimized engine design
- Dual speed

### Fuel system

- Common rail
- Gear driven fuel feed pump
- Six hole fuel injection nozzles
- Electronic governor
- Fuel prefilter with water separator
- Fine fuel filter of cartridge insert type

### Intake and exhaust system

- Connection flange for exhaust line
- Waste gate turbo charger, centre low with exhaust flange
- Two-stage air filter, with cyclon
- Heater flange in charge air inlet (with relay)

### Cooling system

- Belt driven, maintenance-free coolant pump with high degree of efficiency
- Efficient cooling with accurate coolant control through a water distribution duct in the cylinder block
- Reliable thermostat with minimum pressure drop

- Pusher fan

### Electrical system

- Engine Management System 2 (EMS 2), an electronically controlled processing system which optimizes engine performance. It also includes advanced facilities for diagnostics and fault tracing
- The instruments and controls connect to the engine via the CAN SAE J1939 interface, either through the Control Interface Unit (CIU) or the Display Control Unit (DCU). The CIU converts the digital CAN bus signal to an analog signal, making it possible to connect a variety of instruments. The DCU is a control panel with display, engine control, monitoring, alarm, parameter setting and diagnostic functions. The DCU also presents error codes in clear text.
- Sensors for oil pressure, boost pressure, boost temp, exhaust temp, coolant temp, water in fuel, fuel pressure and two speed sensors.

**VOLVO  
PENTA**

# TAD734GE

## Technical Data

### General

Engine designation .....	TAD734GE	
No. of cylinders and configuration.....	in-line 6	
Method of operation .....	4-stroke	
Bore, mm (in.).....	108 (4.25)	
Stroke, mm (in.).....	130 (5.12)	
Displacement, l (in <sup>3</sup> ).....	7.15 (436.0)	
Compression ratio.....	17:1	
Dry weight, excl. cooling system, kg (lb).....	764 (1684)	
Wet weight, excl. cooling system, kg (lb).....	788 (1737)	

<b>Performance</b>	<b>1500 rpm</b>	<b>1800 rpm</b>
with fan, kW (hp) at:		
Prime Power	213 (290)	216 (294)
Max Standby Power	238 (324)	243 (330)

<b>Lubrication system</b>	<b>1500 rpm</b>	<b>1800 rpm</b>
Oil consumption, liter/h (US gal/h) at:		
Prime Power	0.03 (0.008)	0.03 (0.008)
Max Standby Power	0.03 (0.008)	0.03 (0.008)
Oil system capacity incl filters, liter .....	29	

<b>Fuel system</b>	<b>1500 rpm</b>	<b>1800 rpm</b>
Specific fuel consumption at:		
Prime Power, g/kWh (lb/hph)		
25 %	244 (0.396)	257 (0.417)
50 %	233 (0.378)	237 (0.384)
75 %	217 (0.352)	222 (0.360)
100 %	204 (0.331)	205 (0.332)
Max Standby Power, g/kWh (lb/hph)		
25 %	247 (0.400)	259 (0.420)
50 %	235 (0.381)	239 (0.387)
75 %	217 (0.352)	225 (0.365)
100 %	205 (0.332)	207 (0.336)

<b>Intake and exhaust system</b>	<b>1500 rpm</b>	<b>1800 rpm</b>
Air consumption at 27°C, m <sup>3</sup> /min (cfm):		
Prime Power	16.1 (569)	18.3 (646)
Max Standby Power	16.3 (576)	18.9 (667)
Max allowable air intake restriction, kPa (In wc)	3.0 (12.0)	3.0 (12.0)
Heat rejection to exhaust, kW (BTU/min) at:		
Prime Power	160 (9099)	174 (9895)
Max Standby Power	177 (10066)	189 (10748)
Exhaust gas temperature after turbine, °C (°F) at:		
Prime Power	495 (923)	475 (887)
Max Standby Power	550 (1022)	510 (950)
Max allowable back-pressure in exhaust line, kPa (In wc)	10 (40.2)	10 (40.2)
Exhaust gas flow, m <sup>3</sup> /min (cfm) at:		
Prime power	33.0 (1165)	36.7 (1296)
Max Standby Power	33.4 (1180)	37.9 (1338)

<b>Cooling system</b>	<b>1500 rpm</b>	<b>1800 rpm</b>
Heat rejection radiation from engine, kW (BTU/min)		
Prime Power	24 (1365)	25 (1422)
Max Standby Power	26 (1479)	28 (1592)
Heat rejection to coolant kW (BTU/min)		
Prime Power	117 (6654)	124 (7052)
Max Standby Power	128 (7279)	137 (7791)
Fan power consumption, kW (hp)	11.6 (16)	20.0 (27)

## Standard equipment

### Engine

Automatic belt tensioner •

Lift eyelets •

### Flywheel

Flywheel housing with conn. acc. to SAE 2 •

Flywheel 10" and 11.5" disc •

Vibration damper •

### Engine suspension

Fixed integrated radiator front engine suspension •

### Lubrication system

Oil dipstick •

Full-flow oil filter of cartridge type •

Oil cooler, side mounted •

### Fuel system

Common rail •

Fuel filters of cartridge type •

Pre-filter with water separator •

### Intake and exhaust system

Two-stage air filter with cyclon •

Connecting flange for exhaust pipe •

Turbo charger, low left side •

### Cooling system

Tropical radiator incl intercooler •

Belt driven coolant pump •

Fan hub •

Pusher fan •

Fan guard •

Belt guard •

### Control system

Engine Management System (EMS) with CAN-bus •

interface SAE J1939 and stand alone interface •

### Alternator

Alternator 100A / 24 V •

### Starting system

Starter motor, 5.0kW, 24 V •

### Instruments and senders

Temp.- and oil pressure for automatic •

stop/alarm •

### Engine Packing

Plastic wrapping •

<sup>1)</sup> must be ordered, se order specification

– optional equipment or not applicable

• included in standard specification

## Dimensions TAD734GE

Not for installation

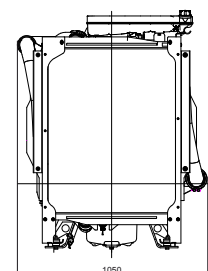
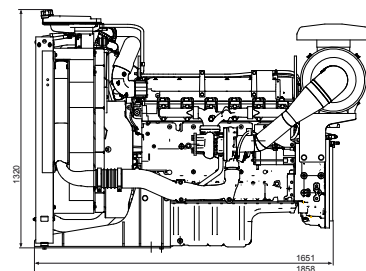

Note! Not all models, standard equipment and accessories are available in all countries.

All specifications are subject to change without notice.

The engine illustrated may not be entirely identical to production standard engines.

### Power Standards

The engine performance corresponds to ISO 3046, BS 5514 and DIN 6271. The technical data applies to an engine without cooling fan and operating on a fuel with calorific value of 42.7 MJ /kg (18360 BTU/lb) and a density of 0.84 kg/liter (7.01 lb/US gal), also where this involves a deviation from the standards. Power output guaranteed within 0 to +2% at rated ambient conditions at delivery. Ratings are based on ISO 8528.

Engine speed governing in accordance with ISO 3046/IV, class A1 and ISO 8528-5 class G3

### Exhaust emissions

The engine complies with EU stage 2 emission legislation according to the Non Road Directive EU 97/68/EC.

### Rating Guidelines

PRIME POWER rating corresponds to ISO Standard Power for continuous operation. It is applicable for supplying electrical power at variable load for an unlimited number of hours instead of commercially purchased power. A10 % overload capability for governing purpose is available for this rating.

MAXIMUM STANDBY POWER rating corresponds to ISO Standard Fuel Stop Power. It is applicable for supplying standby electrical power at variable load in areas with well established electrical networks in the event of normal utility power failure. No overload capability is available for this rating. 1 hp = 1 kW x 1.36

### Information

For more technical data and information, please look in the Generating Set Engines Sales Guide.

# VOLVO PENTA

<http://www.brizmotors.ru/equipment/ctm/v250a/>

# **OPERATOR'S MANUAL**

**9 Liter (EMS 2)**

Volvo TAD734GE

# Presentation

## Engines

This Operator's Manual contains descriptions and maintenance instructions for TAD940GE, TAD941GE, TAD940VE, TAD941VE, TAD942VE, TAD943VE, TAD950VE, TAD951VE and TAD952VE industrial diesel engines.

They are 6-cylinder in-line engines with direct injection. All engines are equipped with electronically controlled fuel management (EMS 2), turbocharger, charge air cooler, thermostatically controlled cooling systems and electronic speed control.

TAD950VE, TAD951VE have TAD952VE are also equipped with internal EGR (Exhaust Gas Recirculation).

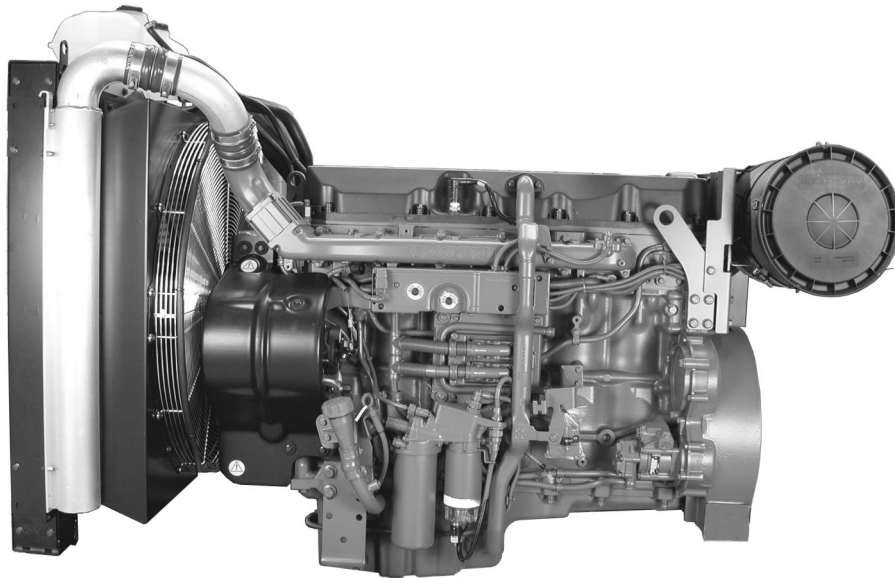

## EMS (Engine Management System)

EMS (Engine Management System) is an electronic system with CAN communication (Controller Area Network) for diesel engine control. The system was developed by Volvo Penta and includes fuel control and diagnostic function.

### Input signals

The control unit receives input signals about engine operating conditions, etc. from the following components:

- coolant temperature sensor
- charge air pressure and charge air temperature sensor
- crankcase pressure sensor
- position sensor, camshaft
- speed sensor, flywheel
- coolant level sensor
- oil level and temperature sensor
- oil pressure sensor
- fuel pressure sensor
- water in fuel indicator

### Diagnostics function

The purpose of the diagnostic function is to detect and locate any malfunctions in the EMS system, to protect the engine and to ensure operation in the event of serious malfunction.

If a malfunction is detected, it is announced by warning lamps, a flashing diagnostic lamp or in plain language on the instrument panel, depending on the equipment used. If a fault code is provided as a flashing code or in plain language, it is used for guidance in any fault tracing. Fault codes can also be read by Volvo's Vodia tool at authorized Volvo Penta workshops.

If there is a serious malfunction, the engine will be shut down altogether, or the control unit will reduce the power delivered (depending on the application). Once again, a fault code is set for guidance in any fault tracing.

### Output signals

The control module uses input signals to control the following components:

- unit injectors
- starter motor
- main relay
- pre-heating relay

Information from the sensors provides exact information about current operation conditions and allows the processor in the control unit to calculate the correct fuel injection volume and timing, check engine status etc.

### Fuel control

The engine fuel requirement is analyzed up to 100 times per second. The amount of fuel injected into the engine and the injection advance are fully electronically controlled via fuel valves in the unit injectors. This means that the engine always receives the correct volume of fuel in all operating conditions, which offers lower fuel consumption, minimal exhaust emissions etc.

# Instruments and Controls

## DCU (Display Control Unit)

The DCU control panel is available as an optional accessory for the EMS (Engine Management System) electronic control system.

The DCU is a digital instrument panel which communicates with the engine control unit. The DCU has several functions, such as engine control, monitoring, diagnostics, and parameter setting.

The menus in the DCU system can be used to check, and in some cases to set, a number of different functions in the EMS system.

**NOTICE!** Settings and what engine data that appears in the display may vary depending on installation and engine model.

**NOTICE!** The menus and illustrations shown here are the English version. The language can be changed, however; refer to the *Setup* menu.

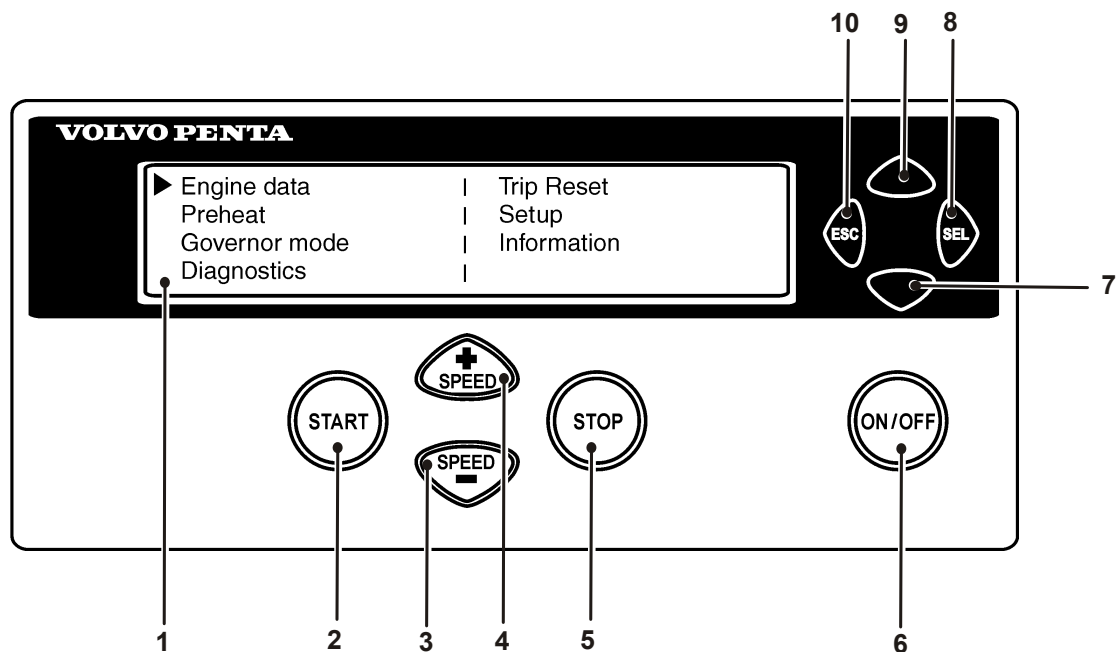

P0002062

### Start

When the DCU panel is started, the "Engine Data" menu is displayed; press "ESC" to come to the main menu.

- |   |                               |    |  |
|---|-------------------------------|----|--|
| 1 | LED display                   | 6  | ON/OFF. Starts and stops the system    |
| 2 | START. Starts the engine      | 7  | Scroll downwards in menus              |
| 3 | SPEED - . Reduces engine rpm  | 8  | SEL. Selects in menus                  |
| 4 | SPEED +. Increases engine rpm | 9  | Scroll upwards in menus                |
| 5 | STOP. Stops the engine        | 10 | ESC. Return to previous menu selection |

▶ <b>Engine data</b>		Trip Reset
Preheat		Setup
Governor mode		Information
Diagnostics		

P0002063

▶ <b>Eng speed</b>	rpm		Boost prs	kpa
Cool tamp	c		Boost tmp	C
Oil pres	kpa		Oil temp	C
Eng hours	h		Batt Volt	V

P0002064

## Menus

There are several sub-menus under each main menu. There is not space for all the menu choices on the display. To scroll through the menus, use the **7** and **9** buttons on the display. Press the **SEL** button **8** to make a selection. Refer to the illustration on the previous page.

**NOTICE!** The **Setup** menu can be used to select the language that you want to use on the display.

## Main menu

- **Engine data**, current engine data
- **Preheat**, manual activation of pre-heating. Must be activated with temperatures below 0°C (32°F)
- **Governor mode**, activation of droop
- **Diagnostics**, shows fault codes as text
- **Trip reset**, resets trip data
- **Setup**, parameter setting
- **Information**, shows the currently applicable hard/software, data sets and engine identification for the engine and DCU data

## Engine data

shows relevant engine data.

- Engine speed, can be controlled with the **SPEED+** and **SPEED-** buttons (rpm)
- Charge pressure (kPa)
- Coolant temperature (°C)
- Charge air temperature (°C)
- Oil pressure (kPa)
- Oil temperature (°C)
- Engine hours (h)
- Battery voltage (V)
- Fuel consumption (l/h)
- Instantaneous fuel consumption (trip fuel) (l)

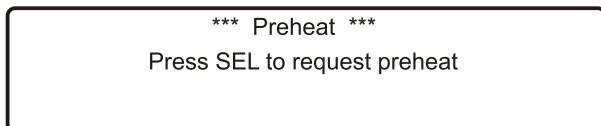

P0002065

## Preheat

manual activation of pre-heating. When it is activated, the EMS system senses at start-up if pre-heating is needed. For automatic pre-heating, refer to the *Setup / Preheat on ignition* menu.

**NOTICE!** Must be activated with temperatures below 0°C (32°F).

The pre-heating time is adjusted to suit the engine temperature, and can last for up to 50 seconds both before and after starting. Refer also to *Starting procedure EMS 2*.

- Press **SEL**, the text **Preheat requested** will be shown
- The display automatically returns to the **Engine Data** menu.

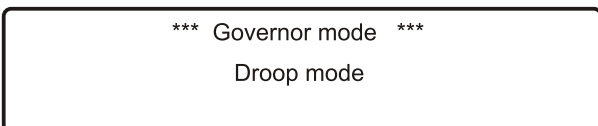

P0002066

## Governor mode

activates/shuts off droop. To set the droop level, refer to the *Setup / Governor gradient or Governor droop* menu.

- Select **Isochronous mode** or **Droop mode** with the SEL button.

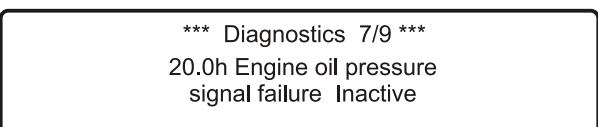

P0002067

## Diagnostics

shows the error list containing the 10 latest active and inactive faults. The fault codes are shown as text on the display.

- Scroll through the fault list with the arrow keys.

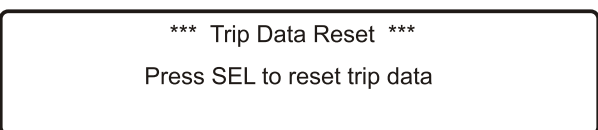

P0002068

## Trip Data reset

resets trip data, such as fuel consumption.

- Press the **SEL** button to reset trip data



Setup	
▶ Set Application :	(Versatile)
Units :	(metric)
Language :	(English)

P0002069

## Setup

parameter setting in the engine's control systems. Different menus appear under **Customer parameter**, depending on whether **Versatile** or **Gen set** has been selected from **Set application**. See below.

The parameters that can be set/selected (choice is made with the SEL button) are:

- **Set application**, setting **Versatile** or **Gen set**. Depending on the selection made here, different menus will appear under **Customer parameter**.
- **Unit**, setting of units (metric or US imperial).
- **Language**, setting the language used on the display. Choose between English, French, German and Spanish.
- **Stop energized to**, setting of external stop input. Activated by **Stop** or **Run**.  
**Stop**: The stop input must be connected to voltage to stop the engine.  
**Run**: The stop input must be connected to voltage to run the engine.
- **Customer parameter**, setting alarm limits. Refer to *Customer parameter / Versatile and Customer parameter / Gen set*.
- **Throttle input setting**, setting of engine-speed control and voltage limits. Refer to *Throttle input setting*.
- *Display setting*, setting the display. refer to *Display setting*.

## Customer parameter / Versatile

- **Idle engine speed** - setting idle speed.
- **Preheat on ignition** - activation of automatic preheating. The engine control system senses if preheating is needed and activates it directly at switch-on.
- **Governor gradient (Nm/rpm)** - setting of droop level, when activated. For activation, refer to *Governor droop* in the main menu.
- **Oil temp warning limit (°C)** - setting alarm limit for oil temperature.
- **Coolant temp warning limit (°C)** - setting alarm limit for coolant temperature.

Set up (Versatile)	
▶ Idle engine speed :	rpm
Preheat on ignition :	
Governor gradient :	Nm/pm

P0002070

Set up (Gen set)	
▶ Primary engine speed	:
Preheat on ignition	:
Governor droop	:

P0002071

## Customer parameter / Gen set

- **Primary engine speed** - selection of engine rpm, 1500 or 1800 rpm.
- **Preheat on ignition** - activation of automatic pre-heating. The engine control system senses if pre-heating is needed and activates it directly at switch-on.
- **Governor droop (%)** - setting of droop level, when activated. For activation, refer to "Governor droop" in the main menu.
- **Overspeed limit (%)** - setting of limit for overspeed alarm, % of set engine rpm.
- **Overspeed shutdown** - activation of engine shut-down with overspeed alarm. Refer to "Overspeed limit" to activate the alarm limit for the excess rpm alarm.
- **Oil temp warning limit (°C)** - setting alarm limit for oil temperature.
- **Coolant temp limit (°C)** - setting alarm limit for coolant temperature.

Setup(Throttle)	
Setup throttle mode : *** OFF ***	

Setup(Throttle)	
▶ Set throttle mode	:
Set idle voltage	:
Set mx voltage	:

P0002955

## Throttle input setting

rpm control setting (throttle operation).

- **Set throttle mode** - OFF - engine rpm is controlled via the DCU panel.  
ext throttle input - engine speed is controlled with a potentiometer (accelerator).  
ext voltage input - engine rpm is controlled by an external unit.
- **Set idle voltage (V)** - idle voltage level setting.
- **Set max voltage (V)** - full throttle voltage level setting.

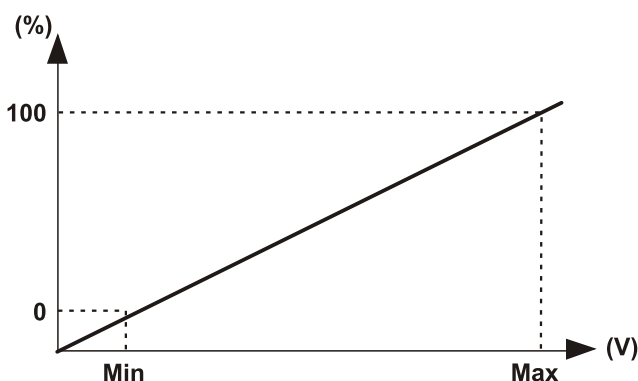

P0002074

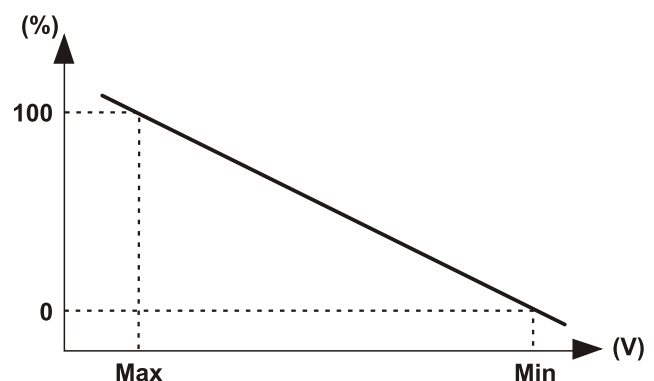



P0002075

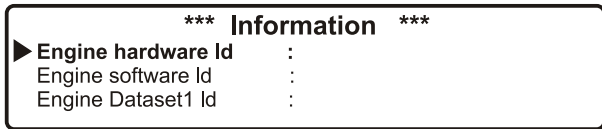

P0002076

## Display setting

settings for the display. Adjustment is made with the **7** and **9** buttons; see DCU panel illustration.

- **Set contrast (%)** - contrast setting.
- **Set backlight time (sec)** - time setting (in seconds) for display backlighting on, lighting is then shut off if the panel is not used.
- **Set backlight brightness** - display backlighting brightness setting.

## Information

shows the data for the engine and DCU.

- **Engine hardware Id** - engine control unit part number.
- **Engine software Id** - engine control unit software part number.
- **Engine dataset1 Id** - engine data set 1 part number.
- **Engine dataset2 Id** - engine data set 2 part number.
- **Vehicle Id** - chassis number.
- **DCU hardware Id** - DCU part number.
- **DCU software Id** - DCU software part number.
- **DCU dataset1 Id** - DCU data set 1 part number.
- **DCU dataset2 Id** - DCU data set 2 part number.

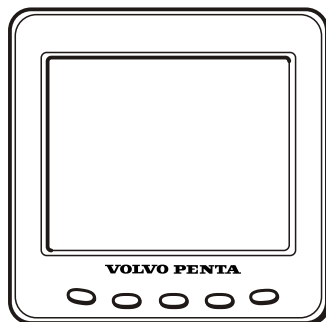

P0002061

## DU (Display Unit)

The DU is a computerized instrument panel which shows engine working values on an LCD screen. In the display it is possible to show multiple windows with different information, i. g. engine rpm, coolant temperature, fuel consumption and fault messages.

At start up, the display performs a self-test. If a constant signal is heard, the system has discovered a malfunction. The display will work but may act in an unexpected way.

The DU is connected between the engine control unit and the CIU or DCU.

### Display modes

Press any of button 1–4 to view the function menu for the buttons, appearing in the lower part of the display. To leave the menu, wait a few seconds or press button 5 (EXIT).

- 1 Engine
- 2 Multi
- 3 Trip
- 4 Graph
- 5 Exit

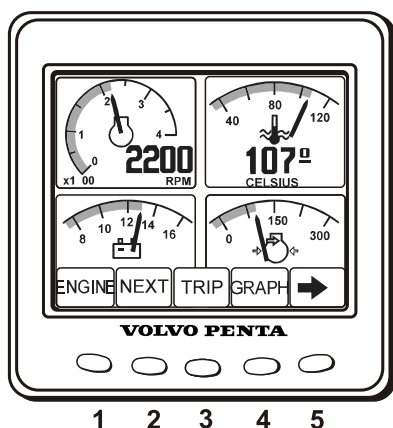

P0002382

### Contrast

In the display modes Engine, Trip and Graph, it is possible to adjust the contrast.

Press button 5 outside the menu and then + (button 4) or – (button 3) to adjust the contrast.

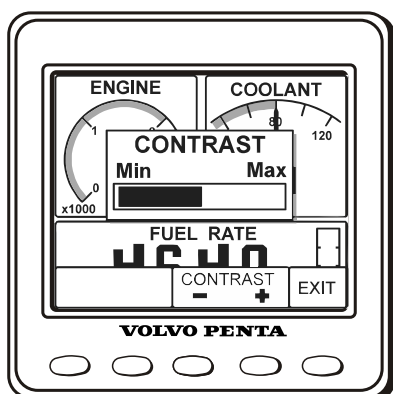

P0002403

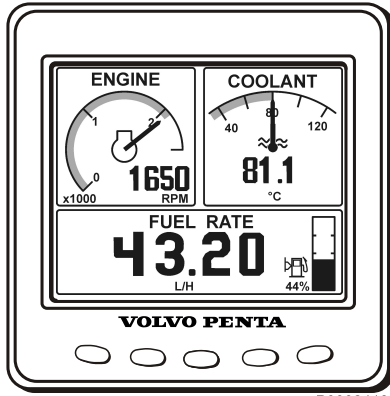

P0002413

### Engine

Rpm and coolant temperature is shown in the upper part of the display. In the lower part it will show trip computer and a fuel level indicator, if these function are installed.

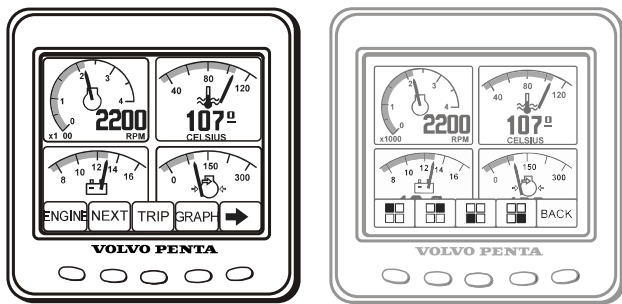

P0014208

### Multi

In the multi mode, button 2, the information can be shown in four windows, analogue or digital. The display toggles between the two when button 2 is pressed repeatedly.

By pressing button 5, the right arrow, you choose what information to be shown in the different windows. Press repeatedly on the button that correspond to the window, until desired information is shown.

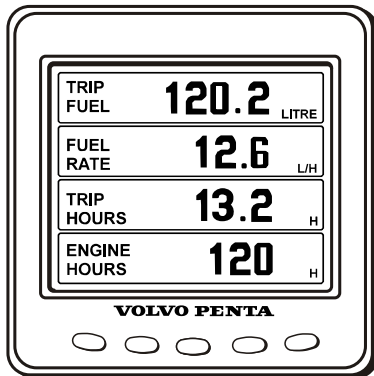

P0002418

### Trip

To display the trip computer press button 3, Trip

- Trip Fuel**, since last reset
- Fuel Rate**, fuel consumption
- Trip hours**, since last reset
- Engine hours**, total amount of operating hours

Reset by pressing button 3 for three seconds until a beep is heard.

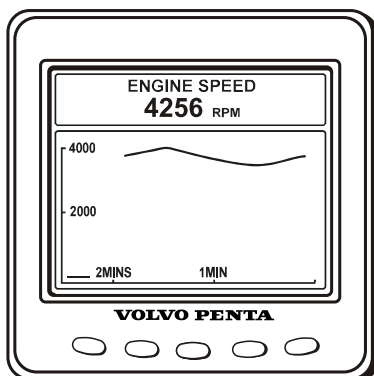

P0014207

### Graph

The information is shown as graphs. Press button 4 repeatedly to choose what information will be shown. The time interval is set in the Configuration menu. If the connection is broken there will be a straight line in the display.

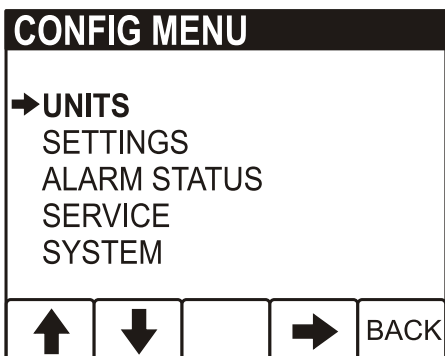

P0014209

### Configuration menu

Press button 5 for three seconds to enter the Configuration menu. Navigate with the up and down arrows, select with the right arrow.

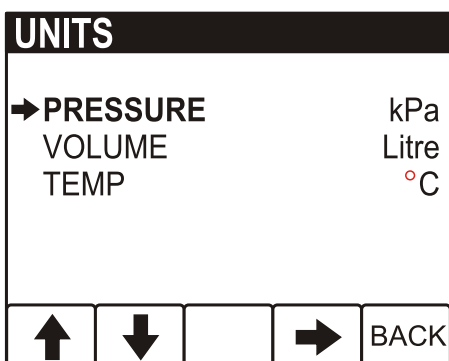

P0014210

### Units

- PRESSURE; kPa, PSI
- VOLUME; LITRE, GAL, Imperial GAL.  
Fuel rate is adjusted according to volume unit, L/H, GAL/H, IGAL/H.
- TEMPERATURE; °C, °F

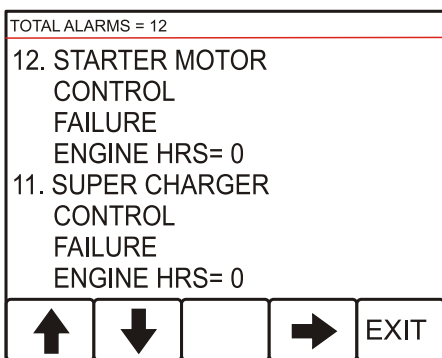

P0014212

### Alarm Status

List of active alarms, refer to *Fault Handling page 34*

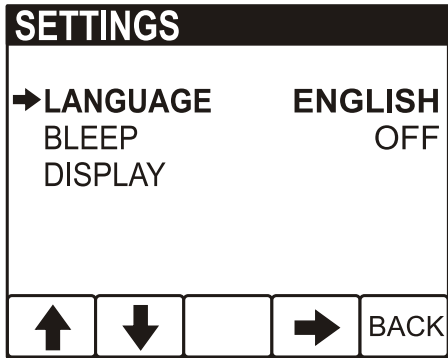

P0014211

**Settings**

- LANGUAGE; setting of what language is to be used in the display.
- BLEEP; On/Off, setting if pressing the instrument buttons will be followed by a beep or not.
- DISPLAY; setting of ENGINE RPM gauges  
RPM ENGINE, 2500–9000 RPM, in steps of 500 RPM  
GRAPH RANGE, 2 minutes– 8 hours in the following steps,  
2MINS, 10MINS, 30MINS, 60MINS, 2HRS, 4HRS, 8HRS

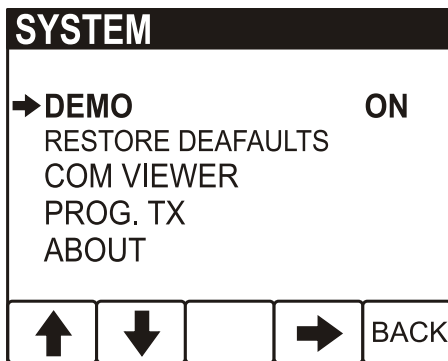

P0014213

**SYSTEM**

- DEMO, switches the DEMO mode ON/OFF.
- RESTORE DEEFAULTS, reset all configuration to default values.
- COM VIEWER, displays latest message on communication ports
- PROG TX, transfers content of the application on Flash memory to other CAN units on the same CAN bus.
- ABOUT, displays  
ID NO – display serial number  
EEPROM – number of write on EEPROM  
VERS – software version number  
CHK – Flash memory checksum  
PART No – Volvo software part number  
SOURCE – source of received data  
LABEL – Allocated Label on the same bus.

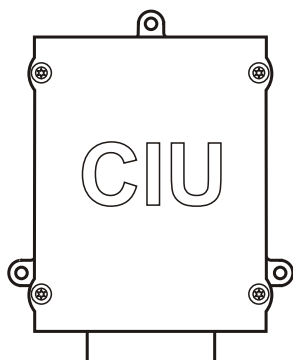

P0002060

## CIU (Control Interface Unit)

The CIU is a "translator" between the control unit (EMS) and the customer's own control panel. The CIU has two serial communication links, one fast and one slow.

The fast one is a so-called CAN link. All data related to instruments, indication lamps, connectors and potentiometers is controlled by this link.

The slow link manages diagnostic information for flashing codes etc.

## Easy Link Instruments

The following Easy Link instruments are available:

- Tachometer / hours counter (fault codes are also displayed on the tachometer display when the diagnostic button is pressed)
- Coolant temperature
- Oil pressure
- Oil temperature
- Battery voltage
- Alarm panel
- Turbo pressure



# Starting

Make it a habit of giving the engine and engine room a visual check before starting. This will help you to discover quickly if anything abnormal has happened, or is about to happen. Also check that instruments and warning displays show normal values after you have started the engine.

## **WARNING!**

Never use start spray or similar agents to start an engine. This may cause an explosion in the inlet manifold. Danger of personal injury.

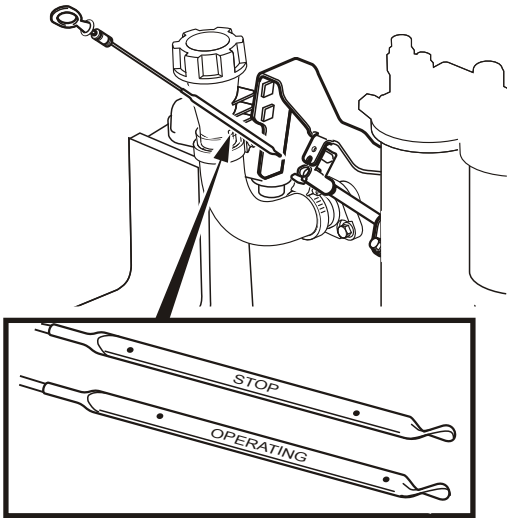

P0004311

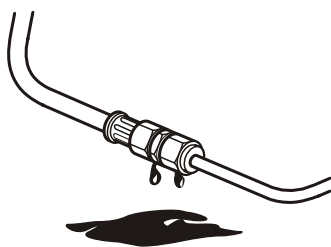

P0002078

## Before Starting

- Check that the oil level is between the MIN and MAX marks.

**NOTICE!** The oil level can be read both when the engine is stopped (the STOP side of the dipstick) and with the engine running (the OPERATING side of the dipstick).

For filling refer to *Oil level, checking and topping up*.

- Open the fuel valves.
- Check the fuel pre-filter; refer to *Draining condensate, fuel system* page 51.
- Check the coolant level and that the radiator is not blocked externally. Refer to *Coolant Level, Checking and Topping Up* page 54 and *Charge Air Cooler, External Cleaning* page 55

## **WARNING!**

Do not open the coolant filler cap when the engine is warm, except in emergencies, this could cause serious personal injury. Steam or hot fluid could spray out.

- Check that no leakage of oil, fuel or coolant is present.
- Turn the main switch(es) on.
- Move the engine speed control to idle, and open the disengageable clutch/gearbox if installed.

## **IMPORTANT!**

Never break the circuit with the main switch while the engine is running, as this may damage the alternator.

## Starting the Engine

### EMS (Engine Management System)

The pre-heating time is adjusted to suit the engine temperature, and can last for up to 50 seconds both before and after starting.

The starter motor connection time is maximized to 20 seconds. After that, the starter motor circuit is cut for 80 seconds to protect the starter motor against overheating.

### DCU (Display Control Unit)

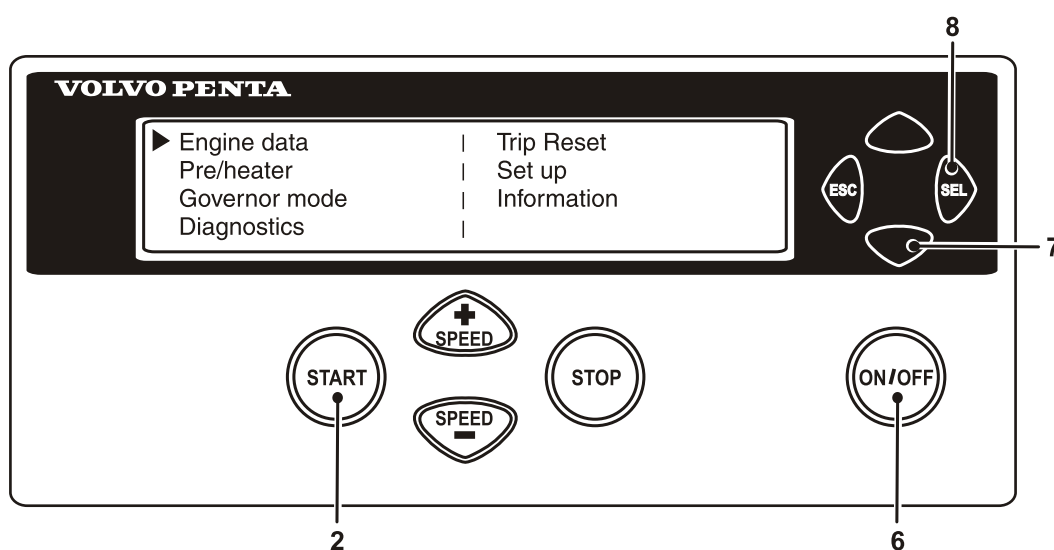

P0002079

#### With pre-heating

- 1 Depress the **ON/OFF**-button (6).
- 2 Press the **SEL** button (8) to come to the main-menu.
- 3 Scroll down to **Pre/heater** with scroll button (7),press **SEL**-button (8)
- 4 In the **pre-heater** menu, press the **SEL**-button (8) to select pre-heating.
- 5 Press the **START**- button (2).

#### Without pre-heating

- 1 Depress the **ON/OFF**-button (6).
- 2 Press the **START**-button (2).

Leave the engine to idle for the first 10 seconds. Then warm the engine up at low speed and under low load. Never race the engine when it is cold.

## Starting in Extreme Cold

Certain preparations must be made to facilitate engine starting, and in some cases to make starting possible at all:

- Use a winter grade fuel (of a well-known make) which has been approved for the relevant temperature. This reduces the risk of wax deposits in the fuel system. At extremely low temperatures, the use of a fuel heater is recommended.
- For fully acceptable lubrication, a synthetic engine oil of recommended viscosity for the relevant temperature should be used. Please refer to the *Maintenance, lubrication system* chapter. Synthetic lubricants are able to manage a wider temperature range than mineral-based lubricants.
- Pre-heat the coolant with a separately installed electric engine heater. In extreme cases, a diesel-burning engine heater may be needed. Ask your Volvo Penta dealer for advice.
- Make sure that the cooling system is filled with a glycol mixture. Please refer to the *Maintenance, cooling system* chapter.
- The batteries should be in good condition. Cold weather reduces battery capacity. Increased battery capacity may be necessary.

## Never Use Start Spray

### **WARNING!**

Never use start spray or similar agents to start an engine. This may cause an explosion in the inlet manifold. Danger of personal injury.

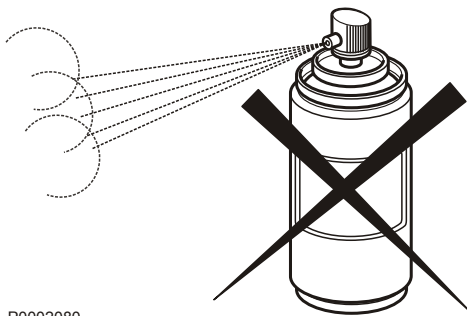

P0002080

## Starting Using Auxiliary Batteries

### **WARNING!**

Explosion hazard. Batteries contain and give off an explosive gas which is highly flammable and explosive. A short circuit, open flame or spark could cause a violent explosion. Ventilate well.

- 1 Check that the auxiliary batteries are connected (series or parallel) so that the rated voltage corresponds to the engine system voltage.
- 2 First connect the red (+) jumper cable to the auxiliary battery, then to the flat battery. Then connect the black (-) jumper cable to the auxiliary battery and to a location that is **somewhere away from the discharged battery**, e.g. the main switch negative terminal or the negative terminal on the starter motor.
- 3 Start the engine.

### **WARNING!**

Do not touch the connections during the start attempt: Risk of arcing.

Do not bend over any of the batteries either.

- 4 Remove the cables in the reverse order.

### **IMPORTANT!**

The ordinary cables to the standard batteries must not be loosened on any condition.

# Operation

Correct operating technique is very important for both fuel economy and engine life. Always let the engine warm up to normal operating temperature before operating at full power. Avoid sudden throttle openings and operation at high engine rpm.

## Reading the Instruments

Check all instruments directly after starting, and then regularly during operation.

**NOTICE!** On engines in continuous operation, the lubrication oil level must be checked at least every 24 hours. Refer to *Oil level, checking and topping up*.

Check all instruments directly after starting, and then regularly during operation.

**NOTICE!** On engines in continuous operation, the lubrication oil level must be checked at least every 24 hours. Refer to *Oil level, checking and topping up*.

## Alarms

If the EMS 2 system receives abnormal signals from the engine, the control unit generates fault codes and alarms, in the form of lamps and audible warnings. This is done by means of CAN signals to the instrument.

More information about fault codes and fault tracing can be found in the chapter. *Fault Handling page 30*.

## Maneuvering

### Operation at low load

Avoid long-term operation at idle or at low load, since this can lead to increased oil consumption and eventually to oil leakage from the exhaust manifold, since oil will seep past the turbocharger seals and accompany the induction air into the inlet manifold at low turbo pressure.

One consequence of this is carbon build-up on valves, piston crowns, exhaust ports and the exhaust turbine.

At low loads, the combustion temperature may become so low that complete combustion cannot be ensured, resulting in possible fuel dilution of lubricating oil and eventually leakage from the exhaust manifold.

If the following points are done as a complement to normal maintenance, there will be no risk of malfunctions caused by operation at low load.

- Reduce operation at low load to a minimum. If the engine is regularly test-run without load once a week, the duration of this operation should be limited to 5 minutes.
- Run the engine at full load for about 4 hours once a year. In this way carbon deposits in the engine and exhaust system are given the chance to burn up.

# Engine Shutdown

During longer breaks in operation, the engine must be warmed up at least once every two weeks. This prevents corrosion in the engine. If you expect the engine to remain unused for two months or more, it must be laid up: Refer to the chapter *Storage* page 61.

## Before Engine Shutdown

Let the engine run for a few minutes without loading before stopping it. This allows engine temperature equalization and prevents boiling once stopped and also allows the turbocharger to cool down. This contributes to long service life without malfunctions.

## Stop the Engine

- Disengage the clutch (if possible).
- Depress the **STOP**-button (5).

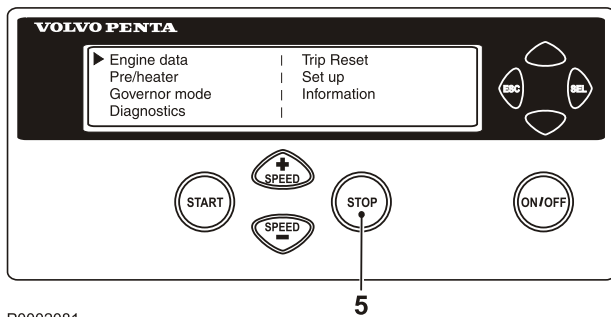

P0002081

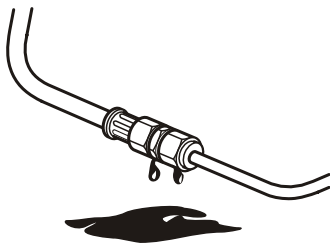

P0002078

## After Engine Shutdown

- 1 Check the engine and engine bay for leakage.
- 2 Turn off the main switches before any long stoppage.
- 3 Carry out maintenance in accordance with the schedule.

### For longer breaks in operation

During longer breaks in operation, the engine must be warmed up at least once every two weeks. This prevents corrosion attacks in the engine.

If you expect the engine to be unused for two months or more, it must be laid up. Refer to the chapter *Short Term Storage*.

**NOTICE!** If there is a risk of frost, the coolant in the cooling system must have sufficient frost protection. Refer to the chapter *Maintenance* page 52.

A poorly-charged battery can freeze and burst; refer to *Battery, Charging* page 60.



P0003479

## Extra Stop

For location of the extra stop, please refer to *Location of Sensors page 43*.

### **WARNING!**

Working with or going close to a running engine is a safety risk. Watch out for rotating components and hot surfaces.



# Fault Handling

## Fault Tracing

A number of symptoms and possible causes of engine malfunctions are described in the table below. Always contact your Volvo Penta dealer if any problems occur which you cannot solve by yourself.

### IMPORTANT!

Read through the instructions for care and maintenance in the *Safety precautions for boat operation* chapter before starting work.

<b>Symptoms and possible causes</b>	
The diagnostics button indicator blinks	Refer to <i>Diagnostic Function</i>
Engine cannot be stopped	2, 5
Starter motor does not rotate	1, 2, 3, 4, 5, 6, 7, 24
Starter motor rotates slowly	1, 2
Starter motor rotates normally but engine does not start	8, 9, 10, 11,
Engine starts but stops again	8, 9, 10, 11, 13
Engine does not reach correct operating speed at full throttle	9, 10, 11, 12, 13, 21, 25, 26
Engine runs unevenly	10, 11
High fuel consumption	12, 13, 15, 25
Black exhaust smoke	12, 13
Blue or white exhaust smoke	14, 15, 22
Lubricating oil pressure too low	16
Coolant temperature too high	17, 18, 19, 20
Coolant temperature too low	20
No charge, or poor charge	2, 23

- 1 Discharged batteries
- 2 Poor contact/open circuit in cables
- 3 Main switch in off position
- 4 Main fuse blown
- 5 Faulty ignition switch
- 6 Faulty main relay
- 7 Faulty starter motor/solenoid
- 8 Lack of fuel:
  - fuel taps closed
  - fuel tank empty/wrong tank connected
- 9 Blocked fuel filter/primary filter (because of contamination, or paraffin fraction separation in fuel at low temperature)
- 10 Air in the fuel system
- 11 Water or contaminants in fuel
- 12 Faulty unit injector
- 13 Insufficient air supply to engine:
  - blocked air filter
  - air leakage between turbocharger and engine inlet manifold
  - fouled compressor section in turbocharger
  - faulty turbocharger
  - poor engine bay ventilation
- 14 Coolant temperature too high
- 15 Coolant temperature too low
- 16 Oil level too low
- 17 Coolant level too low
- 18 Air in the coolant system
- 19 Faulty circulation pump
- 20 Defective thermostat
- 21 Clogged charge air cooler
- 22 Oil level too high
- 23 Alternator drive belt slipping
- 24 Water entry into engine
- 25 High back pressure in exhaust system
- 26 Break in Pot+ cable to pedal

## Diagnostic Function

The diagnostic function monitors and controls the engine and SCR System. The diagnostic function has the following tasks:

- detecting and locating disturbances
- reporting detection of disturbances
- providing guidance when fault tracing

A fault message in the form of a fault code is always generated when a disturbance is detected by the diagnostic function. If the diagnostic function detects a disturbance in the system, this is reported with a fault code via the instruments.

The diagnostic function protects the engine and ensure continued operation by affecting the engine, depending on the severity the engine is affected differently.

Depending on what instrumentation that is being used the fault message is shown in various ways (fault codes can also be read out by VODIA).

All fault codes and fault messages can be found in the Fault Code Register together with information about cause, reaction and actions, for further information see chapter *Fault Code Register*.

## CIU (Control Interface Unit)

When the system detects a malfunction, the diagnostics lamp flashes. If the diagnostics button is pressed and then released, a fault code is flashed out.

The fault code consists of two groups of flashes, separated by a pause of two seconds. A fault code is obtained by counting the number of flashes in each group.

### Example

✱ ✱ pause ✱ ✱ ✱ ✱ = fault code 2.4

The fault code is stored and can be read off as long as the malfunction remains. Information about causes, effects and actions required is available in the Fault Code chapter.

### Do as follows to read off the fault code:

- 1 Press the diagnostics button.
- 2 Release the diagnostics button and note down the fault that is flashed out.
- 3 Repeat items 1–2. A new fault code will be flashed out if more faults are stored. Repeat until the first fault code reappears.

**NOTICE!** When the first fault code reappears, all fault codes have been read off.

If the diagnostics button is pressed after the fault has been rectified and the fault codes have been erased, code 1.1 “No fault” will be displayed.

## DU (Display Unit)

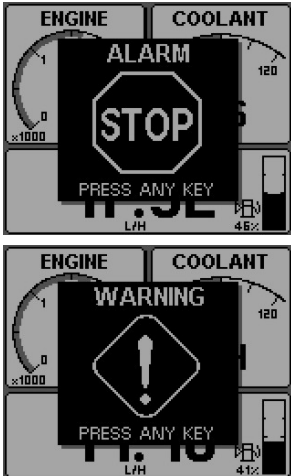

P0014030

- 1 When the system detects a fault, a pop-up is shown on the display. Depending on the severity of the fault the following text will appear **ALARM STOP / PRESS ANY KEY** or **WARNING! / PRESS ANY KEY**; a buzzer will sound.
- 2 Reduce engine speed to idle or shut down the engine.

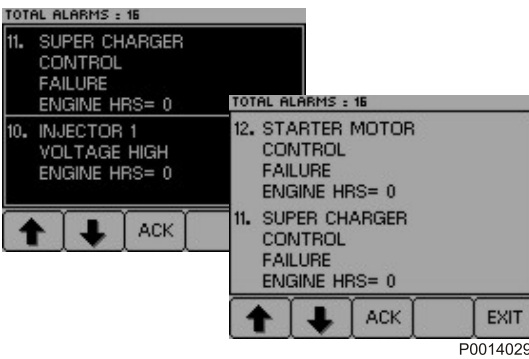

P0014029

- 3 Press the SEL button to get to the fault list. The fault list shows fault messages and the number of hours of operation when the fault occurred.
- 4 Press **ACK** to acknowledge the fault code. The display background changes color (and the buzzer stops). The fault must be acknowledged before it can disappear from the fault list.
- 5 Look up the fault code in the *Fault Code Register* and take the necessary actions.

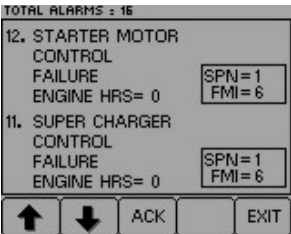

P0014038

- 6 Press button 4 for at least three seconds to view SPN and FMI codes.
- 7 Press **EXIT** to leave the fault list. Alarms that are acknowledged and rectified are automatically erased from the list.

Eng speed	700 rpm	Boost prs	4 kpa	▲
Cool Temp	90 °C	Boost tmp	59 °C	
Oil Pres	480 kpa	Oil Temp	87 °C	
!! ENGINE WARNING !!				
				▼

Eng speed	700 rpm	Boost prs	4 kpa	▲
Cool Temp	90 °C	Boost tmp	59 °C	
Oil Pres	480 kpa	Oil Temp	87 °C	
Press SEL for information				
				▼

P0014037

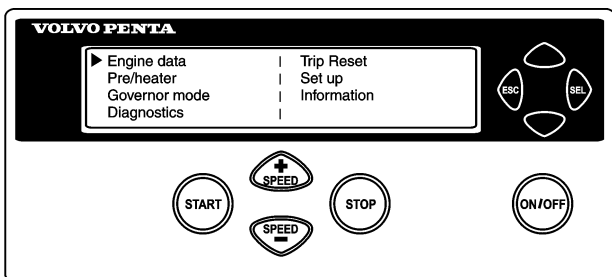

P0014039

## Display Control unit (DCU)

- 1 When a fault is detected the following text is displayed:  
**!! ENGINE WARNING !!** alternating with  
**Press SEL for information.**
- 2 Reduce engine speed to idle or shut down the engine.
- 3 Press the **SEL** button to get to the fault list.  
The fault list shows:
  - hours of operation
  - fault messages
  - active/non-active faults
- 4 Look up the fault code in the *Fault Code Register* and take the necessary actions.
- 5 Press **ESC** to leave the fault list.

**NOTICE!** To get to the fault list when no fault codes are set, press the **SEL** button and select **Diagnostics** from the menu.

## Easy Link Instruments

- 1 When the system detects a fault the diagnostics lamp flashes.
- 2 Press the diagnostics button. The fault code is shown as text in the tachometer display.
- 3 Look up the fault code in the *Fault Code Register* and take the necessary actions.
- 4 When the fault has been rectified, the fault code disappears from the display and the diagnostics lamp goes out.

If the diagnostics lamp is pressed after the fault has been rectified and the fault code erased, the code **1.1, No fault** will be displayed.

## Erasing fault codes

The memory of the diagnostic function is reset when the power to the engine is disconnected. When the power is switched on again the diagnostic function will check if there are any malfunctions in the system. If so a new fault codes is registered.

**NOTICE!** Power must be disconnected completely.

**This means that fault that hasn't been corrected:**

- 1 are shown as active, the active fault code can then be erased with the VODIA tool.
- 2 must be acknowledge and read out every time the engine is switched on.

If the diagnostic button is depressed after the fault has been corrected and fault code deleted, the code **1.1, No fault**, will show.

# Fault Code Register

## Fault code, engine

	SPN	PID	PPID	SID	PSID	Flash code Electrical fault/Value fault	FMI
Coolant Water Pressure	20	20					
Percent Accelerator Pedal Position	91	91				2.7/- (EMS) 2.8/- (CIU)	9
Fuel delivery pressure <i>Maintenance page 49</i>	94	94				3.6/3.8	1, 3, 5, 7
Water in fuel indicator <i>Draining condensate, fuel system page 51</i>	97	97				2.9/2.1	0, 3, 4
Engine Oil Level <i>Oil level, checking and topping up page 47</i>	98	98				5.9/5.7	1, 3, 4, 5
Engine oil filter diff pressure	99						
Engine Oil Pressure <i>Oil level, checking and topping up page 47</i>	100	100				3.1/6.6	1, 3, 5, 18
Boost pressure	102	102					0, 3, 5, 16
Boost Temperature	105	105				3.2/6.2	0, 4, 5, 16
Boost pressure	106	106				3.4/3.5	0, 3, 5, 16
Air filter pressure	107	107				5.5/5.5	0, 3, 4, 5
Ambient air pressure	108	108				-/-	2, 3, 4
Coolant Temperature <i>Coolant Level, Checking and Topping Up page 54</i>	110	110				3.3/6.1	0, 4, 5, 16
Coolant Level <i>Coolant Level, Checking and Topping Up page 54</i>	111	111				2.3/2.2	1, 3, 5
Crankcase Pressure	153	153				7.8/7.7	0, 2, 3, 5
Battery Voltage <i>Battery, Charging page 60</i>	158	158				-/3.9 (EMS) -/6.9 (CIU)	1, 3, 4
Injection control pressure	164	164				8.3	2, 4, 5
Ambient Air Temperature Sensor	171	171					14
Ambient Air Temperature Sensor	172	172				7.9/-	4, 5
Engine Oil Temperature <i>Oil level, checking and topping up page 47</i>	175	175				3.7/5.8	0, 4, 5, 16
Engine Speed	190	190				-/2.6	0, 16
Throttle position	608		98			-/-	9
Throttle calibrated position	608		132			2.8/-	9
SAE J1708 Data Link	608			250		9.2/-	
SAE J1939 Data Link	608				201		9
+5V sensor supply	620			232		9.3/-	3, 4
Inlet Air Temperature	626	45				5.4/-	3, 4, 5
Program memory	628			240		9.9/-	2, 12
Controller error	629			254		9.9/- (EMS) 9.8/- (CIU)	8, 12



	SPN	PID	PPID	SID	PSID	Flash code Electrical fault/Value fault	FMI
Calibration Memory EEPROM	630			253		9.9/- (EMS) 9.8/- (CIU)	2, 12, 14
Camshaft sensor	636			21		2.5/-	2, 3, 8
Flywheel sensor	637			22		2.4/-	2, 3, 8
SAE J1939 Data Link	639			231		6.5/- (EMS) 6.4/- (CIU)	2
Cooling fan control	647			33			3, 4, 5
Fuel Injector, Cylinder #1	651			1		7.1/-	3, 4, 5, 12
Fuel Injector, Cylinder # 2	652			2		7.2/-	3, 4, 5, 12
Fuel Injector, Cylinder #3	653			3		7.3/-	3, 4, 5, 12
Fuel Injector, Cylinder #4	654			4		7.4/-	3, 4, 5, 12
Fuel Injector, Cylinder #5	655			5		7.5/-	3, 4, 5, 12
Fuel Injector, Cylinder #6	656			6		7.6/-	3, 4, 5, 12
Starter motor relay	677			39		4.6/-	3, 4, 5
Injection Control Pressure Regulator	679				42	8.3/-	3, 4, 5, 6,
Pressure Release Valve	679				97	8.3	0, 7, 11, 14
Starter element	729			70		8.6	3, 4, 5
Stop Input, EMS	970		6			4.8/- (EMS)	4
Fan speed	975	26					3
Compression break	1072		122				1, 3, 4, 5
+5V sensor supply	1079			232		9.3/-	3, 4
+5V sensor supply 2	1080			211		9.3/-	3, 4
ECU temperature	1136		55			8.4	16
Exhaust Temperature	1184	173				4.9/1.9	0, 4, 5, 16
Wastegate Valve	1188			32			3, 4, 5
SAE J1939 Data Link	1231				232		2
SAE J1939 Data Link	1231				229		9
Rail pressure system	1239				96	8.3	0, 1, 4, 7, 12, 16
Engine synchronizing	1377		98				9
Main relay output	1485		5			5.1/-	
Starter Output	1675		3				0, 3, 4, 5, 10
Starter Output	1675			39			0, 3, 4, 5, 10
Data Link	2017				201		9
Internal EGR	2791		19			8.5	3, 4, 5, 7
Starter Output	2898		3				3, 4, 5
Starter Output	2899		3				3, 4
Thermostat bypass valve	2988		332				3, 4, 5
Exhaust gas temperature sensor #1	3241		386				0, 7, 4, 5
Sensor Supply Voltage #1 (+5V DC)	3509			232			3, 4
Sensor Supply Voltage #2 (+5V DC)	3510			211			3, 4

	SPN	PID	PPID	SID	PSID	Flash code Electrical fault/Value fault	FMI
Piston cooling oil pressure	4811		8				1, 2, 3, 5, 18
Piston cooling pressure	520192					6.8/6.7	1, 3
Starter input sensor	520194		4			4.7/- (EMS) 5.2/- (CIU)	
Stop Input, CIU	520195		6			5.3/- (CIU)	4
Frequncy select input			113				
Diagnostic request switch input			259				
Oil pressure warning lamp status			260			4.1/-	
Coolant level warning lamp status			261			4.5/-	
Diagnostic lamp status			262				
Run indication lamp status			263			4.3/-	
Over speed indication lamp status			264			4.4/-	
Coolant temperature warning lamp output			7			4.2/-	

# Maintenance Schedule

Your Volvo Penta engine and its equipment are designed for high reliability and long life. It is built so as to have minimal environmental impact. If given preventive maintenance, according to the maintenance schedule, and if Volvo Penta original spares are used, these properties are retained and unnecessary malfunctions can be avoided.

## CAUTION!

Read the chapter on Maintenance before starting work. It contains instructions on how to carry out maintenance and service operations in a safe and correct manner.

When both operation and calendar time are specified, perform the maintenance job at the interval which is reached first.

## Service program

FSI = First Service Inspection  
 S = Special Service  
 A - F = Type of service (regular service)

C = Clean  
 R = Replace  
 L = Lubrication  
 I = Inspection (includes, if necessary, cleaning, adjustment, lubrication and change)

### FSI = First Service Inspection

<b>After the first 100-200 Hours</b>	
Fuel pre-filter, draining water / contamination	I
Coolant Level	I
Drive Belts	I
<b>Start and warm up engine</b>	
Coolant/oil/fuel, leakage	I
Inspection with VODIA (Diagnostic Tool)	I
Engine and transmission, abnormal noises	I
<b>Stop engine</b>	
Engine Oil and Oil Filters / By-pass filter	R
<b>Restart engine</b>	
Oil pressure / oil leakage	I

### S

<b>Every 50-600 Hours</b>	<b>At least every (month)</b>		
	12	24	48
Engine Oil and Oil Filters / By-pass filter	R	•	

### S

<b>After the First 1000 Hours</b>			
Valve clearance	A		
<b>Every 50-600 Hours</b>			
	<b>At least every (month)</b>		
	12	24	48
Engine Oil and Oil Filters / By-pass filter	R	•	

**A**

Every 500 hours		At least every (month)		
		12	24	48
Fuel Tank (sludge trap), Drain	R	•		
Inspection with VODIA (Diagnostic Tool)	I	•		
Fuel pre-filter, draining condensed water	I	•		
Air Filter Inserts (Indicator), Engine	I	•		
Radiator	I	•		
Drive Belts	I	•		
Batteries, electrolyte level	I	•		

**B**

Every 1000 hours		At least every (month)		
		12	24	48
Fuel Filter	R	•		
Air filter insert	R	•		
Fuel pre-filter	R	•		
Coolant filter (if fitted). Not at same time as coolant change	R	•		

**C**

Every 2000 Hours /				
Valve clearance	I			

**D**

Every 2000 Hours /		At least every (month)		
		12	24	48
Turbo	I		•	
Turbo, Wastegate	I		•	
Engine, with Respect to Leakage	I		•	
Engine hoses, cables and clamps	I		•	
Engine, cleaning and painting	I		•	
Air Filter, Tank Breather	R		•	
Air Filter, Compressor	R		•	

**E**

Every 4000 hours		At least every (month)		
		12	24	48
Belt Tensioner	I		•	
Drive Belts	R		•	
Coolant (green)	R		•	

**F**

Every 8000 hours		At least every (month)		
		12	24	48
Coolant VCS (yellow)	R			•

# Maintenance

This chapter describes the most common maintenance items, see *Service program* for service intervals.

**NOTICE!** Service points which are not described here must be performed by authorized Volvo Penta workshop.

## ⚠ CAUTION!

Read the chapter on Maintenance before starting work. It contains instructions on how to carry out maintenance and service operations in a safe and correct manner.

## ⚠ WARNING!

Care and maintenance work should be done with the engine stopped unless otherwise specified. Stop the engine before opening or removing the engine hatch/hood. Make it impossible to start the engine by removing the start key and cutting the system voltage with the main switches.

Read about security measures for maintenance and service in the chapter *Safety Information page 3* before you begin.

## Orientation

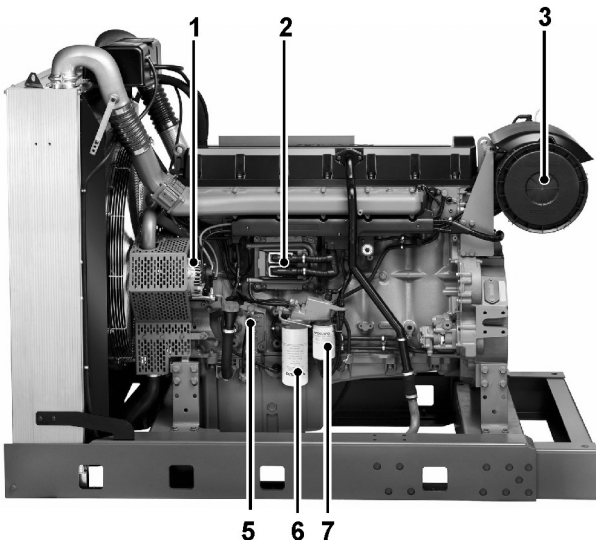

- 1 Alternator
- 2 Control unit EMS 2
- 3 Air Filter
- 4 Oil dipstick
- 5 Fuel filter, with fuel pressure monitor
- 6 Fuel prefilter with water monitor
- 7 Expansion tank
- 8 Charge air cooler (only TAD)
- 9 Starter motor
- 10 Oil filter

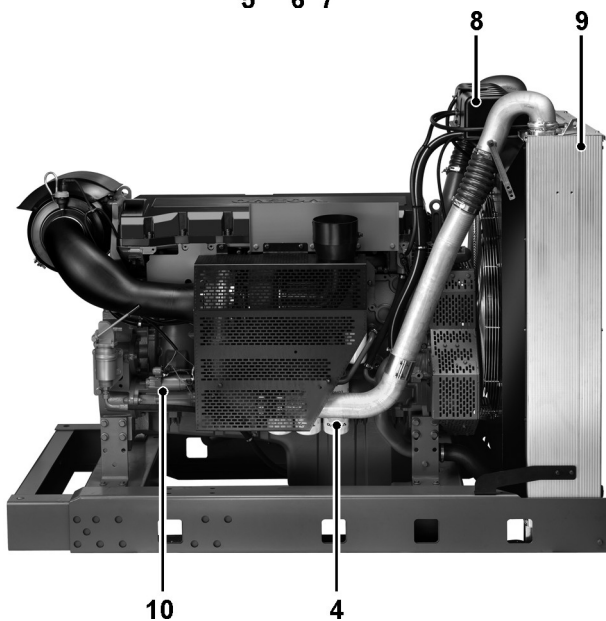

P0014600

## Location of Sensors

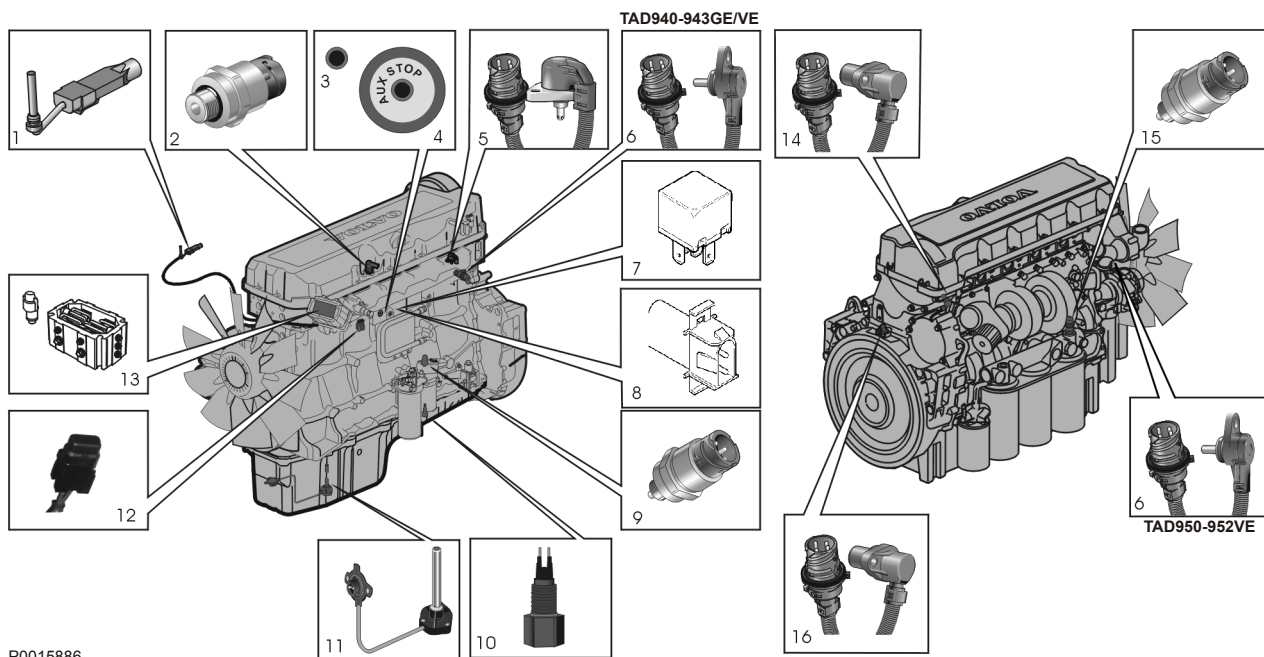

P0015886

- |   |                                   |
|---|-----------------------------------|
| 1 Coolant level sensor  | 9 Fuel pressure sensor            |
| 2 Crankcase Pressurer   | 10 Water in fuel indicator        |
| 3 Electric feed pump switch   | 11 Oil and temperature sender     |
| 4 Auxiliary stop  | 12 Main fuse                      |
| 5 Charge air pressure / Intake manifold temperature                             | 13 Preheater with preheater relay |
| 6 Coolant temperature sensor  | 14 Camshaft sensor                |
| 7 Main relay  | 15 Flywheel sensor                |
| 8 Diagnosis connector<br>2-pin: TAD940-43VE, TAD940-941GE<br>6-pin: TAD950-51VE |                                   |

## Engine, General

### General inspection

Make it a habit to give the engine and engine bay a visual inspection before starting the engine and after operation once the engine has stopped. This will help you to discover quickly if anything abnormal has happened, or is about to happen.

Look especially carefully at oil, fuel and coolant leakage, loose bolts, worn or poorly tensioned drive belts, loose connections, damaged hoses and electrical cables. This inspection only takes a few minutes and can prevent serious malfunctions and expensive repairs.

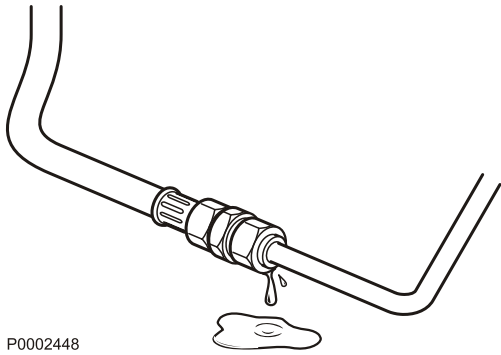

P0002448

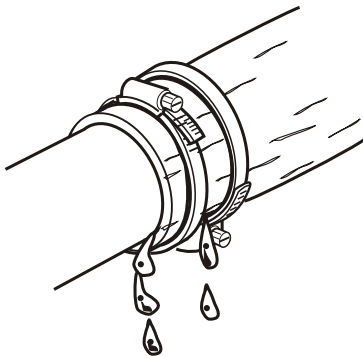

P0002455

### ⚠ WARNING!

Accumulations of fuel, oil and grease on the engine or in the engine room is a fire hazard and must be removed immediately they are detected.

### ⚠ WARNING!

If an oil, fuel or coolant leak is detected, the cause must be investigated and the fault rectified before the engine is started.

### IMPORTANT!

Remember the following when washing with a power washer: Never aim the water jet at radiators, charge air cooler, seals, rubber hoses or electrical components.

## Air Filter, Check and Change

The engine is equipped with electronic air filter indication.

The control unit provides an output signal which is announced as a warning on the instrument panel. The warning indicates a pressure drop in the air filter, which must then be checked and possibly changed.

- Scrap the old filter. No cleaning or re-use is permissible
- In continuous operation, the filter should be checked every 8 hours. For operations in extremely dirty environments such as coal mines and rock crushing mills, special air filters must be used.

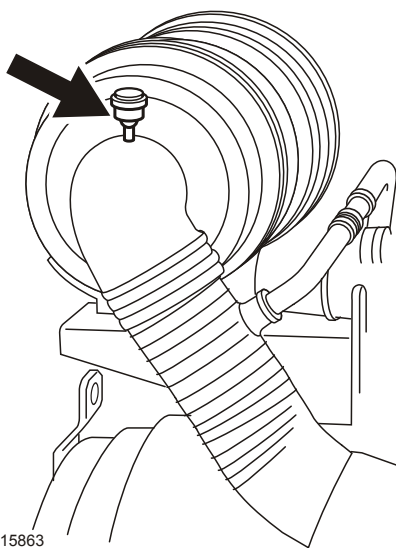

P0015863

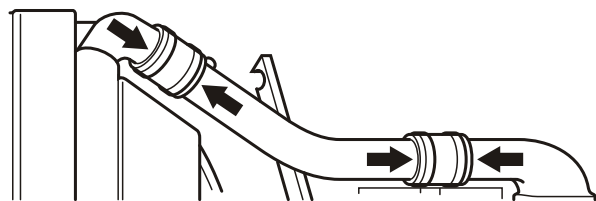

P0015859

## Charge Air Pipe, Leakage Check

Inspect the condition of the charge air hoses, hose unions and clamp condition for cracks and other damage. Change as necessary.

### IMPORTANT!

Clamps must be tightened using a torque wrench to  $9 \pm 2$  Nm ( $6.6 \pm 1.5$  lbf.ft.).

## Drive Belt and Alternator Belt, Inspection

Inspections must be carried out after operations, while the belts are hot.

You should be able to depress the alternator belt and the drive belt about 3-4 mm between the pulleys.

The alternator belts and drive belts have automatic belt tensioners and do not need to be adjusted.

Check the condition of the drive belts. Replace as necessary; refer to *Alternator Belt, Change* page 45 and *Drive Belt, Change* page 46.

## Alternator Belt, Change

### IMPORTANT!

Always change a drive belt which appears worn or cracked.

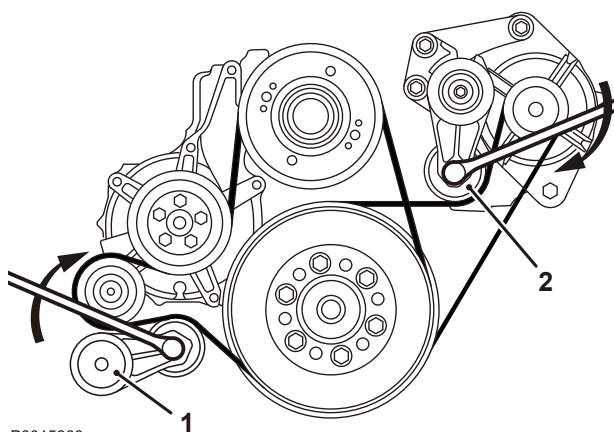

P0015860

- 1 Disconnect the main switch(es) and check that the engine is not connected to system voltage.
- 2 Remove the fan guard and fan ring round the cooling fan.
- 3 Remove the belt guard.
- 4 Insert a 1/2" square wrench in the belt tensioner (1). Lift the wrench up and lift the water pump drive belt off.
- 5 Insert a 1/2" square wrench in the belt tensioner (2). Press the wrench down and remove the alternator belts.
- 6 Check that the pulleys are clean and undamaged.
- 7 Press the 1/2" wrench in the belt tensioner (2) down and install the new alternator drive belt.
- 8 Lift the 1/2" wrench in the belt tensioner (2) and install the new water pump drive belt.
- 9 Install the belt guards.
- 10 Install the fan guard and fan ring round the cooling fan.
- 11 Start the engine and do a function check.



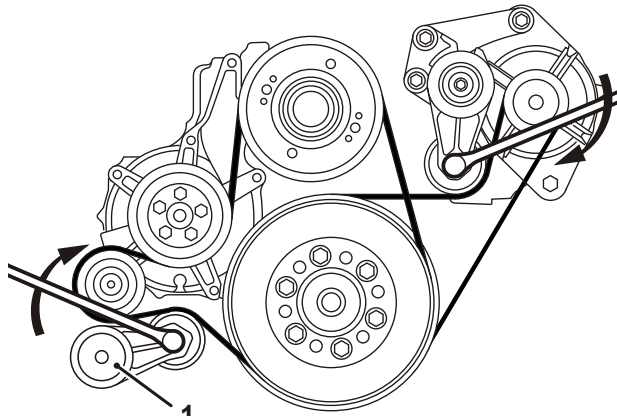

P0015862

## Drive Belt, Change

- 1 Disconnect the main switch(es) and check that the engine is not connected to system voltage.
- 2 Remove the fan guard and fan ring round the cooling fan.
- 3 Remove the belt guard.
- 4 Insert a 1/2" square wrench in the belt tensioner (1). Lift the wrench and remove the drive belt.
- 5 Thread the drive belt round the fan and remove it.
- 6 Check that the pulleys are clean and undamaged.
- 7 Thread the new drive belt over the fan.
- 8 Lift the 1/2" wrench and install the new drive belt.
- 9 Install the belt guards.
- 10 Install the fan guard and fan ring round the cooling fan.
- 11 Start the engine and do a function check.

## Lubrication System

Oil change intervals may vary according to the lubrication oil grade and fuel sulfur content. **Refer to Technical data, Lubrication system.**

**NOTICE!** Oil change intervals must never exceed a period of 12 months.

If longer oil change intervals than those given in Technical data are required, the condition of the oil must be checked by the oil manufacturer via regular oil tests.



P0002089

### Oil level, checking and topping up

The oil level must be inside the marked area on the oil dipstick and must be checked daily before the first start.

- The oil level can be read both when the engine is stopped (the STOP side of the dipstick) and when it is running (the OPERATING side of the dipstick). Never fill past the MAX limit on the oil dipstick. Only use Volvo Penta recommended oils; refer to *Technical Data page 65*.
- Only fill when the engine is stopped. Fill oil through the oil filler; refer to *Maintenance page 42*. Check that the correct level is attained; wait a few minutes before reading off the level so that the oil has time to run down into the oil sump.
- The oil level sensor only measures the oil level when the ignition is switched to on, i.e. not continually during operation.

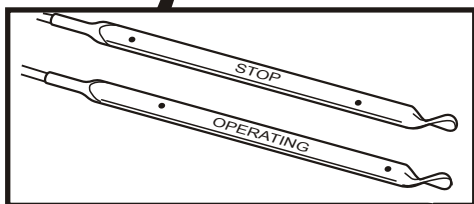
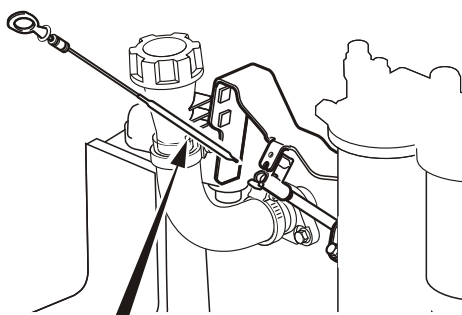

P0004311

## Engine Oil, Change

### **⚠ WARNING!**

Hot oil and hot surfaces can cause burns.

Oil changes must be done when the engine is warm.

- 1 Connect the drain hose to the oil drain pump and check that no leakage can occur.
- 2 Pump the oil out (or remove the bottom drain plug and drain the oil).  
Collect all the old oil and old filters, and leave them at a re-cycling station for destruction.
- 3 Remove the drain hose (or install the bottom drain plug).
- 4 Fill with engine oil.  
For change volume, please refer to *Technical Data* page 65.

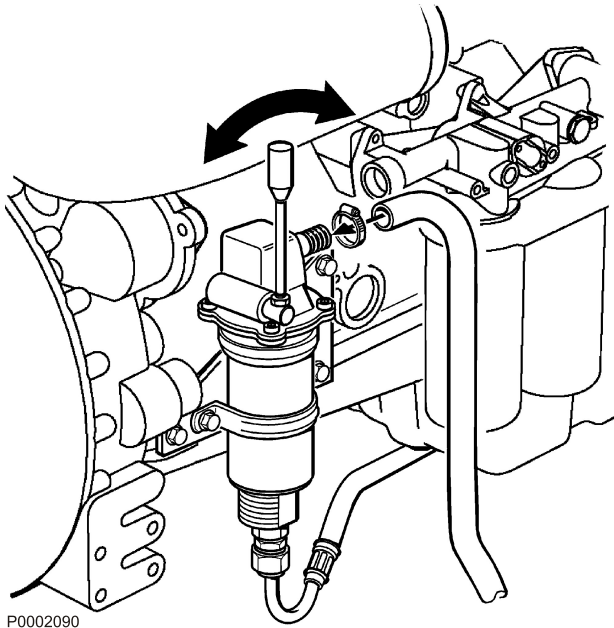

P0002090

## Oil Filter/By-pass Filter, Change

### **⚠ WARNING!**

Hot oil and hot surfaces can cause burns.

- 1 Clean the oil filter bracket (2).
- 2 Remove all oil filters with a suitable oil filter extractor (1).
- 3 Clean the mating surface of the oil filter bracket. Make sure that no pieces of old oil seal are left behind. Carefully clean round the inside of the protective rim (2) on the oil filter bracket.
- 4 Put a thin layer of engine oil on the seal rings of the new fuel filters.
- 5 Install the new oil filters. Tighten the filters  $\frac{3}{4}$ –1 turn after they touch.
- 6 Top up with engine oil, start the engine and let it run for 20-30 seconds.
- 7 Turn off the engine, check the oil level and top up as required.
- 8 Check sealing round the oil filters.

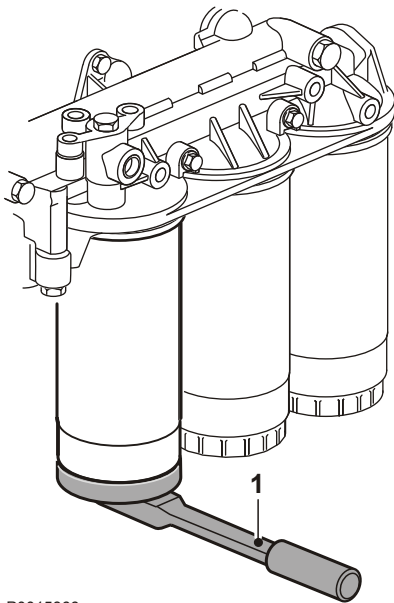

P0015866

## Fuel System

### **WARNING!**

Fire hazard. When carrying out work on the fuel system make sure the engine is cold. A fuel spill onto a hot surface or an electrical component can cause a fire. Store fuel soaked rags so that they can not cause fire.

Only use the grades of fuel recommended in the fuel specification below, please refer to *Technical Data page 66*. Always observe the greatest cleanliness during re-fueling and work on the fuel system.

### **IMPORTANT!**

All work on the injection system of the engine must be done by an authorized workshop.

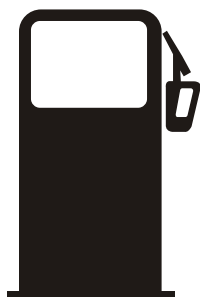

P0002101

## Engine Fuel Filter Replacement

### **WARNING!**

Fire hazard. When carrying out work on the fuel system make sure the engine is cold. A fuel spill onto a hot surface or an electrical component can cause a fire. Store fuel soaked rags so that they can not cause fire.

### **IMPORTANT!**

Do not fill the new fuel filter with fuel before assembly. There is a risk that contamination could get into the system and cause malfunctions or damage.

- 1 Clean round the fuel filter.
- 2 Remove the filter with a suitable filter remover. Collect any spilled fuel in a collection vessel.
- 3 Clean the filter mating surface on the filter bracket.
- 4 Lubricate the seal with diesel fuel and install the new fuel filter. Tighten the fuel filter in accordance with the instructions on the fuel filter.
- 5 If necessary, vent the fuel system, please refer to *Bleeding the Fuel System page 51*.

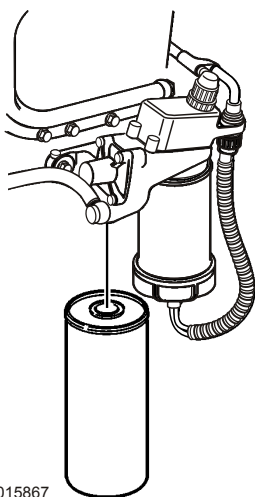

P0015867

## Fuel Pre-filter, Change

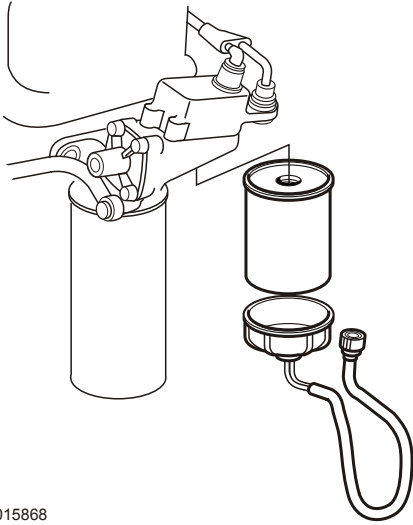

P0015868

- 1 Undo the cable from the water trap sensor.
- 2 Remove the water trap filter from the filter housing. Collect any spilled fuel in a container.
- 3 Remove the lower part of the water trap from the filter.
- 4 Clean the lower part of the water trap with a soft rag. Check that the drain hole in the lower part is not blocked.
- 5 Install a new seal on the lower part and lubricate the seal with diesel fuel. Re-install the lower part of the filter.
- 6 Lubricate the seal with diesel fuel. Screw the filter onto the filter bracket by hand until the rubber seal just touches the mating surface. Then tighten a further half turn, no more.
- 7 Connect the cable to the water trap sensor.
- 8 If necessary, vent the fuel system, please refer to *Bleeding the Fuel System* page 51.

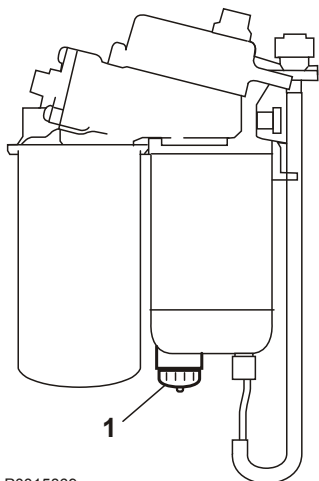

P0015869

## Draining condensate, fuel system

**NOTICE!** Put a collection vessel under the fuel filter to collect the condensate and fuel.

- 1 Open the drain nipple (1) in the base of the fuel pre-filter.
- 2 Tighten the drain tap (1) when water-free fuel begins to run out.

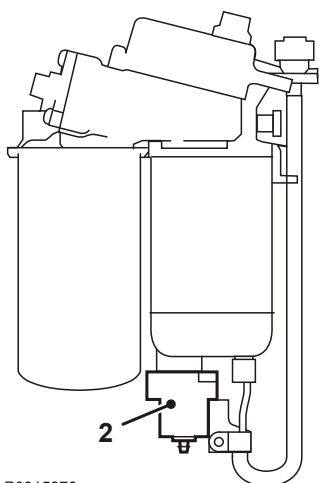

P0015870

### With electric drain nipple.

(only as option on VE engines)

**NOTICE!** Put a collection vessel under the fuel filter to collect the condensate and fuel.

- 1 Activate the electric drain nipple (2) at the base of the primary fuel filter to open it.
- 2 Press the electric feed pump switch until water-free fuel begins to run out; refer to Component locations.
- 3 Switch off the electric drain nipple (2) at the base of the primary fuel filter to close it.

## Bleeding the Fuel System

- 1 Check whether there is enough fuel in the tank, and that any fuel taps are open.
- 2 Turn the ignition on.
- 3 The fuel system is vented by depressing the electric feed pump switch for 1 to 2 minutes.; refer to Component locations. Air is vented to the tank via the fuel return pipe. No venting nipples need be opened.
- 4 Start the engine and allow it to run at a fast idle for about 10 minutes.
- 5 Carry out a leakage and function check.

## Cooling System

The engine's internal cooling system makes sure the engine works at the right temperature. It is a closed system that must always be filled with a mixture of concentrated coolant and water in order to protect the engine against internal corrosion, cavitation and bursting due to freezing.



P0013077

Coolant of a suitable chemical composition must be used all year round. This also applies in areas where there is never any risk of freezing, to provide the engine with full corrosion protection. The use of anti-corrosion agents alone is not permitted in Volvo Penta engines. Never use water alone as a substitute for coolant.

The corrosion protection additives become less effective over time, which means that the coolant must be changed at regular intervals; refer to *Maintenance Schedule*. The cooling system must be flushed whenever the coolant is changed; refer to the *Cooling System, Cleaning* page 56 section.

Volvo Penta coolants have been prepared to work best with Volvo Penta engines and offer excellent protection against corrosion, cavitation damage, and bursts due to freezing. Only coolants of this quality are adapted to, and approved by, Volvo Penta.

### IMPORTANT!

Volvo Penta engines are delivered with either Volvo Penta Coolant (green) or Volvo Penta Coolant VCS (yellow); both are available as concentrates and Ready Mixed.

We recommend that the coolant supplied with the engine on delivery be used. Future warranty claims related to engine and accessories may be denied if an unsuitable coolant has been used, or if the instructions for coolant mixture have not been followed. Engines using yellow Volvo Penta Coolant VCS must have a yellow decal with the text VOLVO COOLANT VCS on the expansion tank.

- The two types of Volvo Penta coolant may **never** be mixed with each other as this will affect the anti-corrosion properties.
- Coolant filters may not be used together with Volvo Penta Coolant VCS.

### Ready Mixed

The ready-mixed coolant protects the engine from corrosion damage, cavitation damage and bursts due to freezing down to

-28 °C (-18 °F) Volvo Penta Coolant (green).

-24 °C (-11 °F) for Volvo Penta Coolant VCS (yellow).

## Coolant, Mixing

### **WARNING!**

All coolant is hazardous and harmful to the environment. Do not consume. Coolant is flammable.

### **IMPORTANT!**

Never race the engine when it is cold.

The concentrated coolant must be mixed with pure water (distilled or de-ionized water) according to specifications; refer to *Water Quality* page 67.

#### **Mix: 40% concentrated coolant and 60% water**

This mixture prevents against internal corrosion, cavitation and bursts due to freezing down to  
-28°C (-18°F) Volvo Penta Coolant (green).  
-24°C (-11°F) Volvo Penta Coolant VCS (yellow).

At 60% glycol concentration, the freezing point is lowered to

-54°C (-65°F) Volvo Penta Coolant (green).

-46°C (-51°F) Volvo Penta Coolant VCS (yellow).

Never mix in more than 60% of the concentrated coolant. A greater volume of concentrate entails a reduced cooling effect with the risk for overheating and reduced anti-freeze protection.

It is extremely important that the system be filled with the correct coolant concentration. Mix in a separate clean vessel before filling the cooling system. Make sure that the liquids mix.

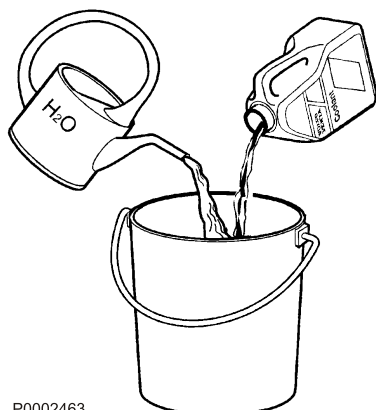

P0002463



## Coolant Level, Checking and Topping Up

### ⚠ WARNING!

Do not open the coolant filler cap when the engine is warm, except in emergencies, this could cause serious personal injury. Steam or hot fluid could spray out.

### IMPORTANT!

Filling of coolant must be performed with the engine stopped. Fill slowly to allow air to flow out.

## Coolant Level, Checking and Topping Up

**NOTICE!** Only use the coolant recommended by Volvo Penta.

**NOTICE!** Open only the filler cap (1). Do not open the pressure cap (2).

Check the coolant level daily before starting.

- 1 Check that the coolant level is above the MIN mark on the expansion tank.
- 2 Top up with coolant as required, so that the level is between the MIN and MAX marks.

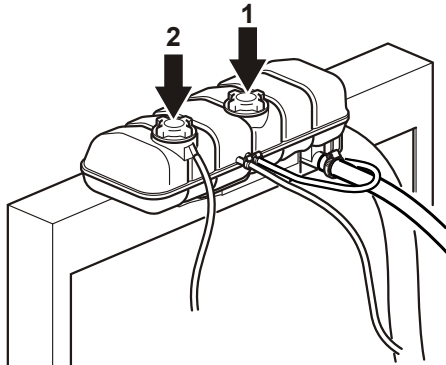

P0015872

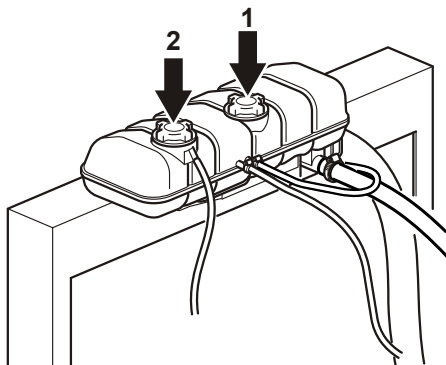

P0015872

## Filling a completely empty system

**NOTICE!** Mix the correct amount of coolant in advance to ensure that the cooling system is completely filled. Refer to *Technical Data page 67* for the correct coolant quantity.

**NOTICE!** Do not start the engine until the system is vented and completely filled.

- 1 Check that all drain points are closed.
- 2 Open the filler cap (1). Do not open the pressure cap (2).
- 3 Fill with coolant so that the level is between the MIN and MAX marks.
- 4 Start the engine when the cooling system has been completely filled and vented. Open any venting taps a short while after starting, to allow trapped air to escape.  
If a heating unit is connected to the engine cooling system, the heat control valve must be opened and the installation vented during filling.
- 5 Stop the engine after about an hour and check the coolant level; top off as necessary.

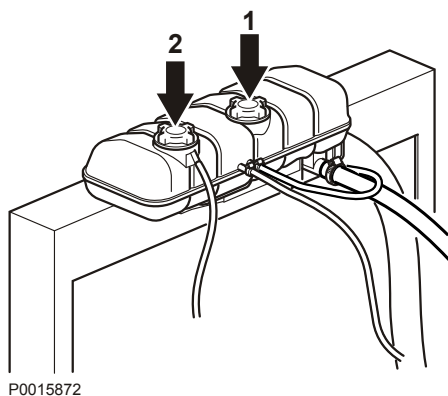

P0015872

## Coolant, Draining

### **WARNING!**

Do not open the coolant filler cap when the engine is warm, except in emergencies, this could cause serious personal injury. Steam or hot fluid could spray out.

### **IMPORTANT!**

Do **not** drain the engine cooling system if the engine is to be laid up or put in storage. The coolant contains corrosion protection additives.

**NOTICE!** Do not open the pressure cap (2).

- 1 Stop the engine before draining the coolant.
- 2 Remove the filler cap (1).
- 3 Open all drain points. Drain the coolant from the radiator and engine block using a drain hose. The drain nipples are located under the radiator on the right side of the engine block.
- 4 Check that all coolant drains out. Deposits may be found inside the drain plug/tap; they must to be cleared away. There is otherwise a risk that coolant could remain and cause damage due to freezing. Check whether the installation has any further taps or plugs at the lowest points of the coolant lines.
- 5 Shut any taps and check that the spring-loaded covers on the nipples close completely. Install the rubber plugs.

## Charge Air Cooler, External Cleaning

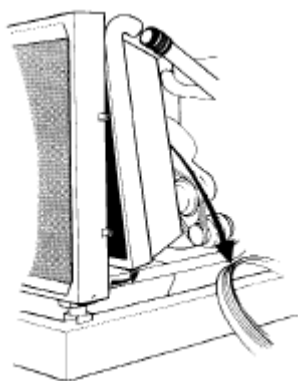

Remove guards as necessary, to access the radiator. Clean with water and a mild detergent. Use a soft brush. Be careful not to damage the radiator vanes. Reinstall removed parts.

### **IMPORTANT!**

Do not use a pressure washer.

## Coolant Filter, Change

**NOTICE!** Only applies to engines using Volvo Penta Coolant (green). Engines using Volvo Penta Coolant VCS are not fitted with coolant filters.

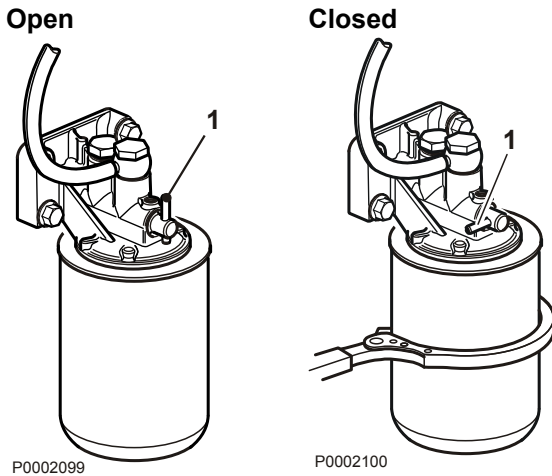

- 1 Turn the tap (1) 90° to stop the flow through the coolant filter.
- 2 Remove the coolant filter with a suitable extractor. Make sure that no residue from the old seal remains in the housing.
- 3 Put a thin layer of engine oil on the new coolant filter seal. Screw the coolant filter on by hand until the seal comes into contact with the mating surface of the filter bracket. Then tighten the coolant filter a further 1/2 turn.
- 4 Turn the tap (1) 90° to release the flow through the coolant filter again.
- 5 Start the engine and perform a leakage check.
- 6 Switch the engine off and check the coolant level. Refer to *Coolant Level, Checking and Topping Up* page 54.

## Cooling System, Cleaning

Cooling performance is reduced by deposits in the radiator and cooling galleries. The cooling system should be cleaned out when the coolant is changed.

### IMPORTANT!

Cleaning must not be done if there is any risk of the cooling system freezing, since the cleaning solution does not have any frost prevention ability.

### IMPORTANT!

It is extremely important that the correct concentration and volume of coolant is put in the system. Mix in a separate clean vessel before filling the cooling system. Make sure that the liquids mix.

- 1 Empty the cooling system. Refer to *Coolant, Draining* page 55.
- 2 Put a hose into the expansion tank filling hole and flush with clean water, as specified by Volvo Penta—refer to section *Water quality* in *Technical Data* page 67 until the water draining out is completely clear.
- 3 If there should still be some contamination left after flushing for a long time, cleaning can be done with coolant. Otherwise, continue as in item 8 below.
- 4 Fill the cooling system with 15-20 % mixture of concentrated coolant. Use only Volvo Penta recommended concentrated coolant mixed with clean water.

- 5 Drain the coolant after 1-2 days of operation. Remove the filler cap and possibly the lower radiator hose to increase the speed of emptying. To prevent suspended material from settling back in the system, emptying should be done rapidly, within the space of 10 minutes, when the engine has not been standing still for a long time.
- 6 Flush the system immediately and thoroughly with clean hot water to prevent dirt from settling in the inner areas. Flush until the water that runs out is completely clean. Make sure that any heater controls are set to full heating during emptying.
- 7 If contamination should still be left after a long period of flushing, you can do a cleanout with Volvo Penta radiator cleaner, followed by finishing-off with Volvo Penta neutralizer. Carefully follow the instructions on the package. Otherwise, continue as in item 8 below.
- 8 When the cooling system is completely free from contamination, close the drain taps and plugs.
- 9 Fill up with Volvo Penta recommended coolant, following the instructions in the chapters entitled *Maintenance page 52* and *Coolant Level, Checking and Topping Up page 54*.

## Electrical System

The engine is equipped with a 2-pole electrical system and an alternator. System voltage is 12V or 24V.

### **WARNING!**

Always stop the engine and break the current using the main switches before working on the engine.

## Main switch

### **IMPORTANT!**

Never disconnect the current with the main switches when the engine is running, the alternator and electronics could be damaged.

The main switches must never be switched off before the engine has stopped. If the circuit between the alternator and the battery is disconnected when the engine is running, the alternator and electronics can be damaged. For the same reason the charging circuits must never be re-connected with the engine running.

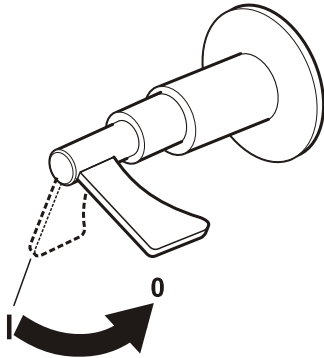

P0002576

## Fuses

The engine is equipped with a 10 A circuit breaker which cuts the current if overloaded.

The circuit breaker is located on the left-hand side of the engine *Location of Sensors page 43*.

The engine stops if the fuse trips. If the circuit breaker trips frequently, an authorized Volvo Penta workshop should be contacted to investigate the cause of the overload.

## Electrical Connections

Check that electrical connections are dry, free from oxide, and that they are securely tightened.



P0016901



P0002107

## Battery, Maintenance

### ⚠ WARNING!

Risk of fire and explosion. Never allow an open flame or electric sparks near the battery or batteries.

### ⚠ WARNING!

Never confuse the positive and negative poles on the batteries. Risk of arcing and explosion.

### ⚠ WARNING!

The battery electrolyte contains extremely corrosive sulfuric acid. Protect your skin and clothes when charging or handling batteries.

Always use protective goggles and gloves. If battery electrolyte comes into contact with unprotected skin wash off immediately using plenty of water and soap. If battery acid comes in contact with the eyes, flush immediately with plenty of water and obtain medical assistance without delay.

## Connecting and disconnecting the battery

### Connecting

- 1 Connect the + cable (red) to the + pole on the battery.
- 2 Connect the – cable (black) to the – pole on the battery.

### Disconnecting

- 1 Remove the – cable (black).
- 2 Remove the + cable (red).

### Cleaning

Keep the batteries clean and dry. Contamination and oxide on the batteries and battery poles can cause stray currents, voltage drop and discharge, especially in wet weather. Remove oxidation from the battery poles and terminals, using a brass brush. Tighten the terminals securely and grease them with terminal grease or petroleum jelly.

### Filling

The electrolyte level should be 5–10 mm (0.2– 0.4”) above the cell plates in the battery. Top up with distilled water as required.

After filling, the battery should be charged for at least 30 minutes by running the engine at idle.

Some maintenance-free batteries have special instructions, which must be followed.

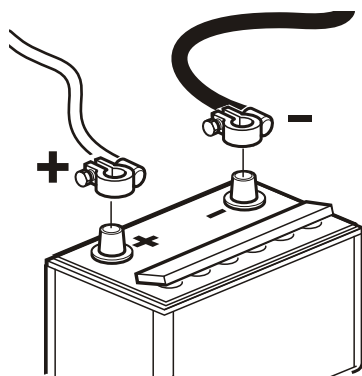

P0016902

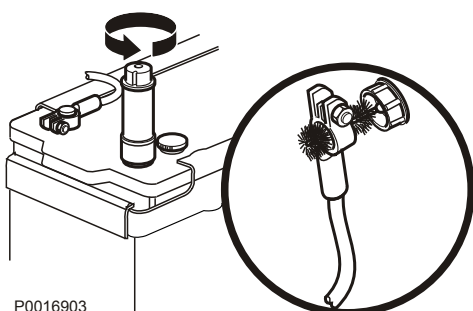

P0016903

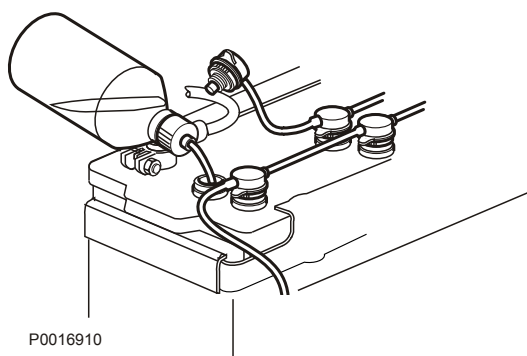

P0016910



P0002107

## Battery, Charging

### ⚠ WARNING!

Risk of fire and explosion. Never allow an open flame or electric sparks near the battery or batteries.

### ⚠ WARNING!

The battery electrolyte contains extremely corrosive sulfuric acid. Protect your skin and clothes when charging or handling batteries.

Always use protective goggles and gloves. If battery electrolyte comes into contact with unprotected skin wash off immediately using plenty of water and soap. If battery acid comes in contact with the eyes, flush immediately with plenty of water and obtain medical assistance without delay.

### ⚠ WARNING!

Never confuse the positive and negative poles on the batteries. Risk of arcing and explosion.

### IMPORTANT!

Observe the instruction manual for the battery charger carefully. To avoid the risk of electrochemical corrosion when an external charger is connected, the battery cables should be removed from the batteries before the charger is connected.

Always switch off the charging current before the charging clips are removed.

- Charge batteries if they have become discharged. During charging, unscrew the cell plugs but leave them in the plug holes. Ventilate well, especially if the batteries are charged in an enclosed space.
- If the engine is not used for a longer period of time, the batteries should be fully charged, then possibly trickle charged (please refer to the battery manufacturer's recommendations). Batteries are damaged by being left discharged, and can also freeze and burst easier in cold weather.
- Special instructions apply to **boost charging**. Boost charging can shorten battery life, and should therefore be avoided.

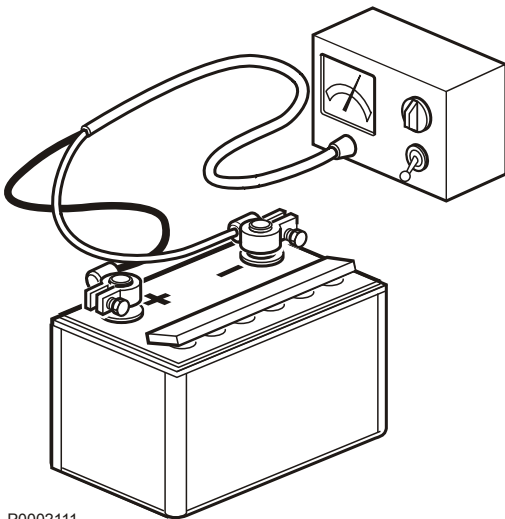

P0002111

# Storage

The engine and other equipment must be laid up to prevent damage if they are not used for two months or more. It is important that this is done in the correct manner, and nothing is forgotten. For this reason, we have compiled a check list of the most important points.

Before the engine is taken out of service for a long period of time, an authorized Volvo Penta workshop should check it over. Have any faults and deficiencies attended to, so that the equipment is in order, ready for the next start.

## CAUTION!

Read the chapter on Maintenance before starting work. It contains instructions on how to carry out maintenance and service operations in a safe and correct manner.

## WARNING!

Conservation oils can be flammable and dangerous to breathe. Ensure good ventilation. Use a protective face mask when spraying.

## IMPORTANT!

Remember the following when washing with a high pressure washer: Never aim the water jet at seals, rubber hoses or electrical components.



P0002089

- **For up to 8 month's stoppage:**  
Change the oil and oil filter on the engine, then warm it up afterwards.
- **More than 8 month's stoppage:**  
Conserve the lubrication and fuel systems with conservation oil. Please refer section *Conservation of the lubrication and fuel systems for more than 8 months' stoppage*.
- Check that the coolant offers sufficient frost protection. Top up as necessary.  
Alternatively, you can drain the coolant (also drain the coolant filter).
- Drain any water and contamination from the fuel filters and fuel tank. Fill the fuel tank completely, to avoid condensation.
- Disconnect the battery cables, clean and charge the batteries. Trickle charge the batteries while the equipment is in storage. **A poorly charged battery can freeze and burst.**
- Clean the outside of the engine. Do not use a high pressure washer for engine cleaning. Touch up paint damage with Volvo Penta original paint.
- Spray the components of the electrical system with water-repellent spray.
- Check and rust-proof any control cables.
- Put a note on the engine with the date, type of conservation and the conservation oil used.
- Cover over the air filter, exhaust pipe and engine if necessary.



## Bringing out of storage

- Remove any covers from the engine, air filter and exhaust pipe.
- Put the correct grade of oil into the engine, if necessary, refer to *Technical Data, Lubrication System*. Install a new oil filter if the filter was not changed during conservation.
- Install new fuel filters and vent the fuel system.
- Check the drive belt(s).
- Check the condition of all rubber hoses, and retighten the hose clamps.
- Close the drain taps and install any drainplugs.
- Check the coolant level. Top up as necessary.
- Connect the fully charged batteries.
- Start the engine and warm it up at fast idle with no loading.
- Check that no oil, fuel or coolant leakage occurs.

## Conservation of the lubrication and fuel systems for more than 8 months' stoppage:

- Drain the engine oil and fill up with **conservation oil\*** to just over the MIN marking on the dipstick.
- Connect the fuel suction and return hoses to a 1/3 full jerrican containing **conservation oil\*** and 2/3 diesel fuel.
- Vent the fuel system.
- Start the engine and run at a fast idle until about 2 liters (0.6 US gals) of the fluid in the jerrican have been used. Stop the engine and connect the ordinary fuel pipes.
- Drain the engine's conservation oil.
- Follow the other instructions on the previous page.

\* Conservation oils are sold by oil companies.

# Technical Data

## Engines

Type designation	TAD940GE	TAD941GE
Power, prime/stand-by	Refer to the sales literature	
Torque, Prime/Standby	Refer to the sales literature	
Compression ratio	20.2:1	17.4:1
Low idle, r/min.	600–1200	600–1200
High idle, rpm	1500–1620 1800–1920	1500–1620 1800–1920
Highest full load speed	1500/1800	1500/1800
No. of valves	24	24
No. of cylinders	6	6
Bore, mm (inch)	120 (4.72)	120 (4.72)
Stroke, mm (inch)	138 (5.43)	138 (5.43)
Displacement, (inch <sup>3</sup> )	9.36 (571)	9.36 (571)
Weight, dry, kg (lbs)	1015 (2238)	1015 (2238)
Weight, wet, kg (lbs)	1065 (2348)	1065 (2348)
Firing order	1-5-3-6-2-4	1-5-3-6-2-4

Type designation	TAD940VE	TAD941VE	TAD942VE	TAD943
Power, prime/stand-by	Refer to the sales literature			
Torque, Prime/Standby	Refer to the sales literature			
Compression ratio	20.2:1	20.2:1	20.2:1	20.2:1
Low idle, r/min.	600	600	600	600
High idle, rpm	2250	2250	2250	2250
No. of valves	24	24	24	24
No. of cylinders	6	6	6	6
Bore, mm (inch)	120 (4.72)	120 (4.72)	120 (4.72)	120 (4.72)
Stroke, mm (inch)	138 (5.43)	138 (5.43)	138 (5.43)	138 (5.43)
Displacement, (inch <sup>3</sup> )	9.36 (571)	9.36 (571)	9.36 (571)	9.36 (571)
Weight, dry, kg (lbs)	1015 (2238)	1015 (2238)	1015 (2238)	1015 (2238)
Weight, wet, kg (lbs)	1065 (2348)	1065 (2348)	1065 (2348)	1065 (2348)
Firing order	1-5-3-6-2-4	1-5-3-6-2-4	1-5-3-6-2-4	1-5-3-6-2-4

Type designation	TAD950VE	TAD951VE	TAD952VE
Power, prime/stand-by	Refer to the sales literature		
Torque, Prime/Standby	Refer to the sales literature		
Compression ratio	20.2:1	20.2:1	20.2:1
Low idle, r/min.	600	600	600
High idle, rpm	2250	2250	2250
No. of valves	24	24	24
No. of cylinders	6	6	6
Bore, mm (inch)	120 (4.72)	120 (4.72)	120 (4.72)
Stroke, mm (inch)	138 (5.43)	138 (5.43)	138 (5.43)
Displacement, (inch <sup>3</sup> )	9.36 (571)	9.36 (571)	9.36 (571)
Weight, dry, kg (lbs)	1015 (2238)	1015 (2238)	1015 (2238)
Weight, wet, kg (lbs)	1065 (2348)	1065 (2348)	1065 (2348)
Firing order	1-5-3-6-2-4	1-5-3-6-2-4	1-5-3-6-2-4

## Lubrication System

<b>Oil</b>	
Oil capacity including oil filters, approx.:	35litre (9.25 US gal)
<b>Oil pressure, hot engine:</b>	
at operating speed	300-600 kPa (44–87 psi)
Oil pressure during neutral	270 kPa
<b>Oil filter</b>	
Full flow filter	2
By-pass filter	1
<b>Lube Oil Pump</b>	
Type	Gear driven

### Oil recommendations

Oil grade	Sulfur content in fuel, by weight		
	up to 0,5 %	0,5 – 1,0 %	more than 1,0 % <sup>1)</sup>
	Oil change interval: Reached first in operation:		
VDS-3 VDS-2 <sup>2)</sup>	600 hrs / 12 month	300 hrs / 12 month	150 hrs / 12 month

**NOTICE!** Mineral based oil, as well as fully or semi-synthetic, can be used on condition that it complies with the quality requirements above.

1) If sulfur content is > 1.0 % by weight, use oil with TBN > 15.

2) The oil must also comply with at least one of the following specifications ACEA:E7, ACEA:E5, Global DHD-1, API:CI-4 or API:CH-4.

**VDS = Volvo Drain Specification**

**ACEA = Association des Constructeurs Européenne d'Automobiles**

**API = American Petroleum Institute Global**

**DHD = Global Diesel Heavy Duty**

**TBN = Total Base Number**

## Viscosity

Select the viscosity according to the table.

The temperature values refer to stable ambient temperatures.

\* SAE 5W/30 refers to synthetic or semi-synthetic oils.

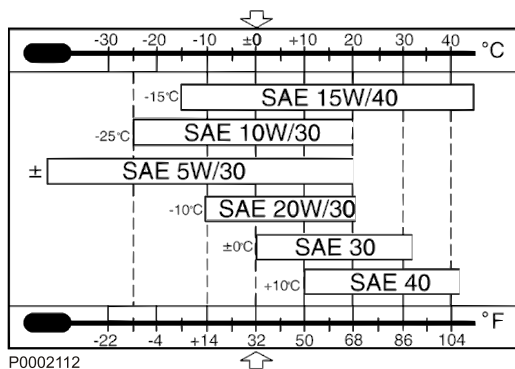

## Fuel System

Feed pump	
Feed pressure at 600 rpm	min 100 kPa (14.5 psi)
Feed pressure at 1200 rpm	min 300 kPa (43,5 psi)
Feed pressure at full load	min 300 kPa (43,5 psi)
Bypass valve	
Opening pressure	400-550 kPa (58–80 psi)

### Fuel specification

The fuel must comply with national and international standards for commercially supplied fuels, such as: **EN 590** (with nationally adapted environmental and cold weather requirements)

**ASTM D 975 No 1-D och 2-D**

**JIS KK 2204**

**Sulfur content:** Complying with legal requirements in each country. If the sulfur content exceeds 0.5 weight-percent, the oil change intervals shall be changed, refer to *Technical Data page 65*.

Extremely low sulfur content fuel (urban diesel in Sweden and city diesel in Finland) can cause a loss of up to 5 % of power and an increase in fuel consumption of about 2-3 %.

### Biodiesel (FAME)

Vegetable oil esters (Fatty Acid Methyl Esters, FAME), also called "biodiesel", are increasingly available as a blending component in diesel fuels. Volvo Penta accepts the same FAME content as in major on-road fuels EN 590 and ASTM D975; i.e. today up to 7%, without any specific additional service requirements. Please contact your Volvo Penta Dealer for further information.

For engines produced after 1 Jan 2009 Volvo Penta accepts, with specific service requirements,

- max 30% FAME blend (FAME component in accordance with EN 14214 and diesel fuel in accordance with EN 590)
- max 20% FAME blend (FAME component in accordance with ASTM D6751 and diesel fuel in accordance with ASTM D975)

#### NOTICE!

Higher FAME blends will negatively impact performance, emissions and fuel consumption. Furthermore the function of the Stage 3B engine exhaust aftertreatment system will be negatively affected.

#### NOTICE!

Engines for emergency applications, e.g. genset standby, must only run with market diesel fuel with minimum FAME content.

#### NOTICE!

Tier 4i engines must only run with market diesel fuel.

#### NOTICE!

In case of cold starting problems shift to diesel fuel. Do not to use FAME below -10°C.

#### NOTICE!

Raw vegetable or animal oils do not meet EN 14214 and are not allowed as fuels or fuel blending components.

## Cooling System

Type	Pressurized, sealed
Pressure cap, max. opening pressure	75 kPa (10.88 PSI)
Coolant quantity (engine):	17 liter (4.49 US gallon)
Coolant quantity (engine, radiator and hoses):	41 liter (10.8 US gallon)
Thermostat, quantity	1 pc.
Thermostat, opening temperature:	82 °C (179.6 °F)



P0013077

### Coolant

Volvo Penta Coolant VCS and VCS Ready Mixed (yellow colour) are based on Organic Acid Technology, OAT.

Volvo Penta Coolant and Coolant Ready Mixed (green colour) are silicate based.

## Water Quality

### ASTM D4985:

Total solid particles	<340 ppm
Total hardness	<9,5° dH
Chloride	<40 ppm
Sulfate	<100 ppm
pH value	5.5–9
Silica (acc. ASTM D859)	<20 mg SiO <sub>2</sub> /l
Iron (acc. ASTM D1068)	<0.10 ppm
Manganese (acc. ASTM D858)	<0.05 ppm
Conductivity (acc. ASTM D1125)	<500 µS/cm
Organic content, COD <sub>Mn</sub> (acc. ISO8467)	<15 mg KMnO <sub>4</sub> /l

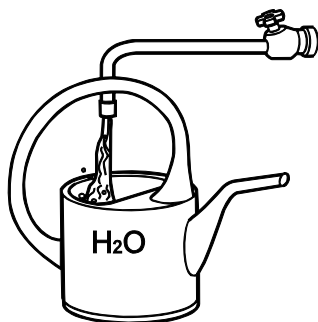

P0002094

## Electrical System

System voltage	24V
Alternator:	
voltage/max. current	28V/80A
output app.	2200 W
Alternative generating equipment (optional):	
voltage/max. current	28V/100A
output app.	2800 W
and	
voltage/max. current	28V/140A
output app.	4000 W
Battery capacity	2 pcs series connected 12V, max. 180 Ah
Battery electrolyte specific gravity at +25°C:	
fully charged battery	1.28 g/cm <sup>3</sup> (1.24 g/cm <sup>3</sup> )*
re-charge battery at	1.20 g/cm <sup>3</sup> (1.20 g/cm <sup>3</sup> )*

\* Note: Applies to batteries with tropical acid.

## Identification Numbers

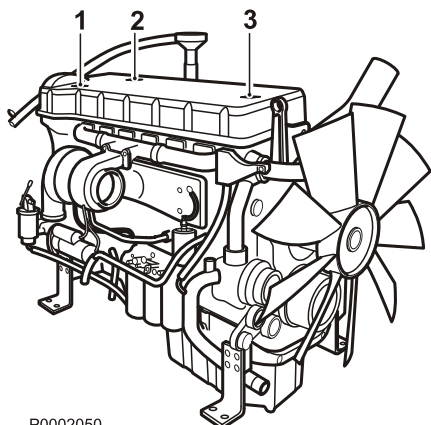

P0002050

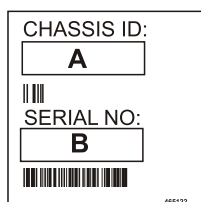

P0002051

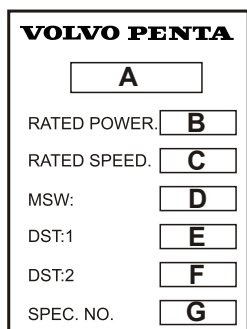

P0002052



P0015924

1  
Chassis and serial number

2  
A Engine designation  
B Engine power, net, (without fan)  
C Max. engine speed  
D Main software  
E Dataset 1  
F Dataset 2  
G Product number

3  
1 Engine designation  
2 Serial number  
3 Specification number