

Technical Data

4000 Series

4008-30TRS1

Gas Engine

Basic technical data

Number of cylinders .. 8
 Cylinder arrangement .. Vertical, In line
 Cycle .. 4 stroke, spark ignition
 Induction system .. turbocharged
 Compression ratio .. 12:1 nominal
 Bore .. 160 mm (6.3 in)
 Stroke .. 190 mm (7.5 in)
 Cubic capacity .. 30,561 litres
 Direction of rotation .. anti-clockwise viewed on flywheel
 Firing order .. 1,4,7,6,8,5,2,3
 Cylinder 1 .. furthest from flywheel
 Total weight of cogeneration unit (engine only)
 Estimated total weight (dry) .. 3350 kg (7385.5 lb)
 Estimated total weight (wet) .. 3528 kg (7777.9 lb)

Overall dimensions

mm (in)	Height	Length	Width
Cogeneration unit			
Natural gas	1671 (65.8)	2559 (100.7)	1400 (55.1)
Bio gas	1782 (70.2)	2559 (100.7)	1418 (55.8)
Electro unit			
Natural gas	1671 (65.8)	2658 (104.6)	1633 (64.3)
Bio gas	1782 (70.2)	2658 (104.6)	1633 (64.3)

Moment of inertia (GD²)

-engine .. 4,12 kgm²
 -flywheel .. 5,92 kgm²
 Cyclic irregularity for engine/flywheel (prime power):
 4008-30TRS1 - 447 kW @ 1500 rev/min .. 1:215
 4008-30TRS2 - 526 kW @ 1500 rev/min .. 1:194

Ratings

This is defined in ISO3046 / 1 (BS5514 / 1 - 1982)
 Electrical ratings are based on stated alternator efficiency and are for guidance only. For Load Acceptance Figures, please refer to Stafford Applications Engineering Department.

Operating Point

Engine speed .. 1500 rev/min
 Ignition timing .. 24° BTDC
 Mixture cooler water temperature .. 45 °C
 Cooling water exit temperature .. < 96 °C
 Exhaust emission .. according to TA-Luft (NOx)

Fuel Data

Lower calorific value .. 34,710 kJ/Sm³ (45.671 kJ/kg)
 Density .. 0,76 kg/Sm³
 Stoich air requirement .. 16 kJ/kg
 Minimum methane number before derate .. 75

Performance

Steady state speed stability at constant load .. ± 0,25%
Note: All data based on operation to ISO 3046/1, BS 5514 and DIN 6271 standard reference conditions.

Test conditions

-air temperature .. 25 °C (77 °F)
 -barometric pressure .. 100 kPa (29.5 in hg)
 -relative humidity .. 30%

General installation

Designation	Units	Continuous baseload rating			
		Cogeneration unit		Electro unit	
		1500 rev/min			
		TRS1	TRS2	TRS1	TRS2
Gross engine power	kW (bhp)	447 (599.4)	526 (705.4)	447 (599.4)	526 (705.4)
Brake mean effective pressure	kPa (lbf/in ²)	11,70 (1.70)	13,70 (1.99)	11,70 (1.70)	13,70 (1.99)
Combustion air flow	m ³ /min (ft ³ /min)	34 (1200.7)	40 (1412.6)	34 (1200.7)	40 (1412.6)
Exhaust gas temperature (max) after turbo	°C (°F)	490 (914)	485 (905)	490 (914)	485 (905)
Exhaust gas flow (max)	m ³ /min (ft ³ /min)	90 (3178.3)	105 (3708.0)	90 (3178.3)	105 (3708.0)
Boost pressure ratio	-	2,53	2,90	2,53	2,90
Overall electrical efficiency	%	37,9	38,5	37,4	38,0
Mean piston speed	m/s (ft/s)	9,5 (31.2)		9,5 (31.2)	
Charge coolant flow	l/sec (UK gal/sec)	8,3 (1.8)		8,3 (1.8)	
Nominal excess air factor (Lambda)	λ	1,71	1,70	1,71	1,70
Typical gross Genset 25 °C (100 kPa) Electrical output (unity 1.0pf)	kWe	425	500	425	500
Assumed alternator efficiency	%	95,0		95,0	

Continuous baseload rating: Power available for continuous full load operation. No overload available.

Energy balance

4008-30TRS1 / 4008-30TRS2 - Cogeneration unit

Designation	Units	1500 rev/min TRS1		1500 rev/min TRS2	
		Continuous baseload rating	%	Continuous baseload rating	%
Energy in fuel	kW	1119	100	1298	100
Energy in power output (Net)	kW	447	39,9	526	40,5
Energy in exhaust	kW	350	31,3	398	30,6
Energy to coolant and oil	kW	189	16,9	211	16,3
Energy to charge cooler	kW	67	6,0	90	6,9
Sum of useable heat	kW	539	48,1	602	46,4
Sum of useable energy	kW	986	88,1	1135	87,4
Energy to radiation	kW	66	5,9	73	5,7

4008-30TRS1 / 4008-30TRS2 - Electro unit

Designation	Units	1500 rev/min TRS1		1500 rev/min TRS2	
		Continuous baseload rating	%	Continuous baseload rating	%
Energy in fuel	kW	1134	100	1315	100
Energy in power output (Net)	kW	447	39,4	526	40,0
Energy in exhaust	kW	353	31,1	402	30,6
Energy to coolant and oil	kW	193	17,0	216	16,4
Energy to charge cooler	kW	69	6,1	92	7,0
Sum of useable heat	kW	615	54,2	710	54,0
Sum of useable energy	kW	1062	93,7	1236	94,0
Energy to radiation	kW	72	6,3	79	6,0

Note: Not to be used for CHP design purposes (indicative figures only). Consult Perkins Engines Company Limited. Assumes complete combustion.

Cooling system

Recommended coolant: 50% inhibited ethylene glycol or 50% inhibited propylene glycol and 50% clean fresh water. For combined heat and power systems and where there is no likelihood of ambient temperature below 10 °C, then clean 'soft' water may be used, treated with 1% by volume of Perkins inhibitor in the cooling system. The inhibitor is available in 1 litre bottles from Perkins.

Total coolant capacity (engine only) ... 48 litres
 Maximum jacket water pressure in crankcase ... 1 bar (plus static pressure head)

Jacket cooling water data	Units	1500 rev/min
Coolant flow	m³/h	36
Coolant exit temperature (max)	°C	96
Coolant entry temperature (max)	°C	88

Charge cooling water data	Units	1500 rev/min
Coolant flow	m³/h	30
Coolant entry temperature	°C	45

Charge cooler ... Fin and tube on engine

Shutdown switch setting... coolant 96 °C rising
 Coolant immersion heater capacity... 4 kW 1 off

Lubrication system

Recommended lubricating oil: Lubricating oil requirements vary with fuel used. Full specifications including oil sampling and recommendations and condemnation limits appear on the Fuel, Coolant and Lubricating Oil Recommendation Sheet for the 4000 Series Gas Engines.

Lubricating oil capacity

Total system ... 165,6 litres
 Sump maximum ... 154,0 litres
 Sump minimum ... 127,0 litres

Lubricating oil temperature

Maximum to bearings... 105 °C
 Lubricating oil pressure at 85 °C temperature to bearings .0,34 MPa

Designation		TRS1	TRS2
Oil consumption (continuous rating)		1500 rev/min	
After RUNNING-IN ††	g/kWhr	0,14	0,14
Oil flow rate from oil pump	l/s	3,7	3,7

†† Typical 250 hours

Sump drain plug tapping size... GA1
 Oil pump... Gear driven
 Shutdown switch setting... oil 1,93 bar falling

Normal operating angles:

-front and rear... 5°
 -side tilt ... 22,5°

Fuel system

Recommended fuel: Natural Gas LHV at 34 MJ/m³ (930 Btu/cu.ft). Other fuels may be used, for example landfill or digester gas. Ratings will vary from those shown.

Where fuels other than Natural Gas are being considered it is imperative that a full gas analysis (including details of any solid or liquid components) be obtained. Reference should then be made to Perkins Engines Company Limited to determine suitability. Gas supplies must be filtered to the same standard as the engine intake air (i.e. Maximum particle size not to exceed 50 microns). Gas supply pressure ... 1,5 kPa to 5 kPa at full rated flow
 Carburettor type ... Deltec with zero pressure regulator

Installation of gas supply and shut off valves to be in accordance with local regulations.

Designation	Cogeneration unit		Electro unit	
	TRS1	TRS2	TRS1	TRS2
Fuel consumption gross	kJ / kW	kJ / kW	kJ / kW	kJ / kW
	1500 rev/min			
At CONTINUOUS Baseload rating	2,51	2,47	2,54	2,50
At 75% of Prime Power rating	2,58	2,53	2,61	2,56
At 50% of Prime Power rating	2,81	2,70	2,84	2,73
At 25% of Prime Power rating	3,63	3,38	3,66	3,41

Fuel: Natural Gas - LHV = 34,71 MJ/m³

Tolerance on Fuel consumption

Designation	Units	Cogeneration unit		Electro unit	
		TRS1	TRS2	TRS1	TRS2
Mass flow data		1500 rev/min			
Fuel	Kg/h	88,2	102,3	89,3	103,6
Volume flow data (100 kPa)					
Fuel (15 °C)	Sm³/hr	116,1	134,6	117,6	136,3

4008-30TRS1 and 4008-30TRS2 Natural gas electro unit - Left view

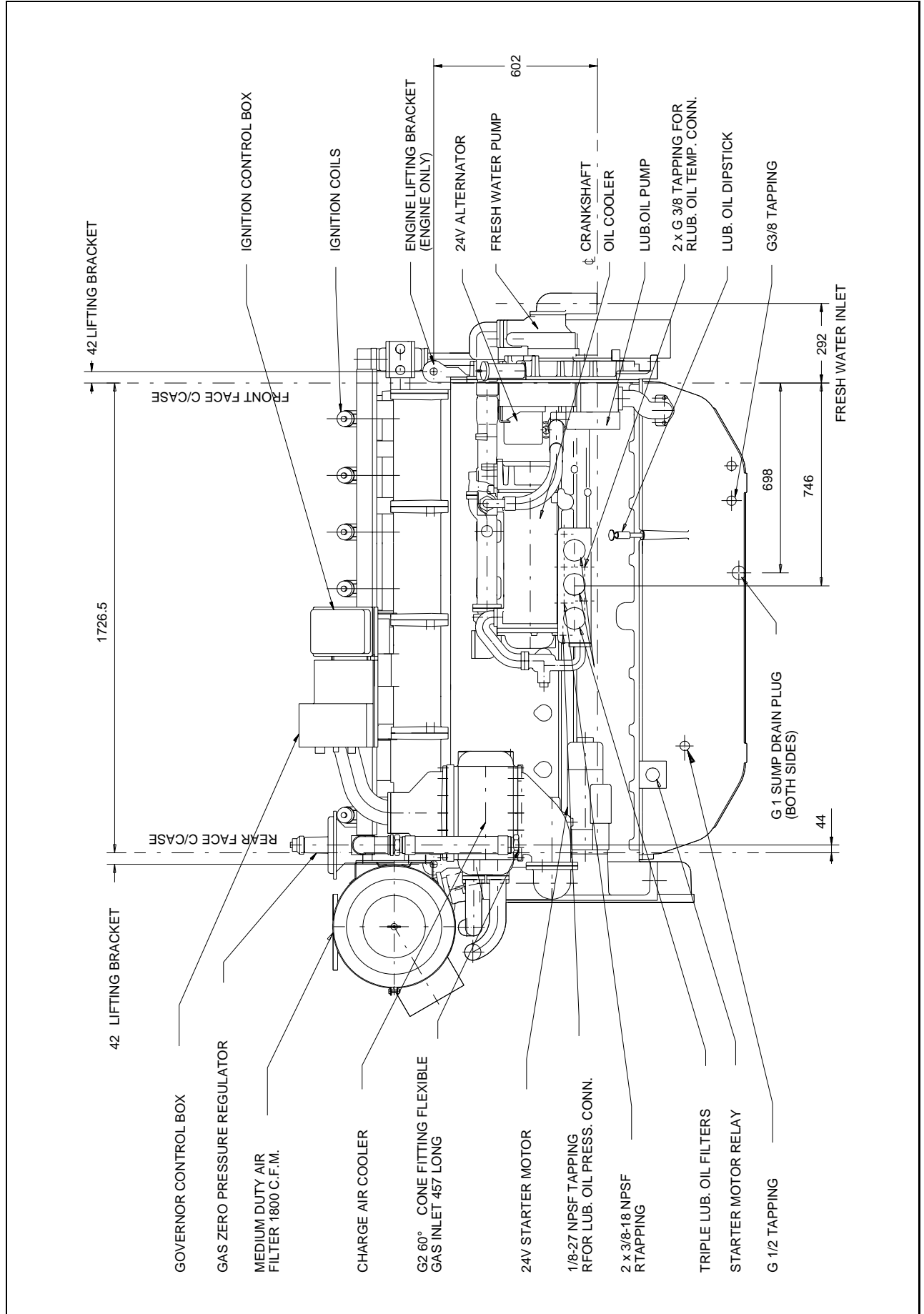

4008-30TRS1 and 4008-30TRS2 Natural gas electro unit - Right view

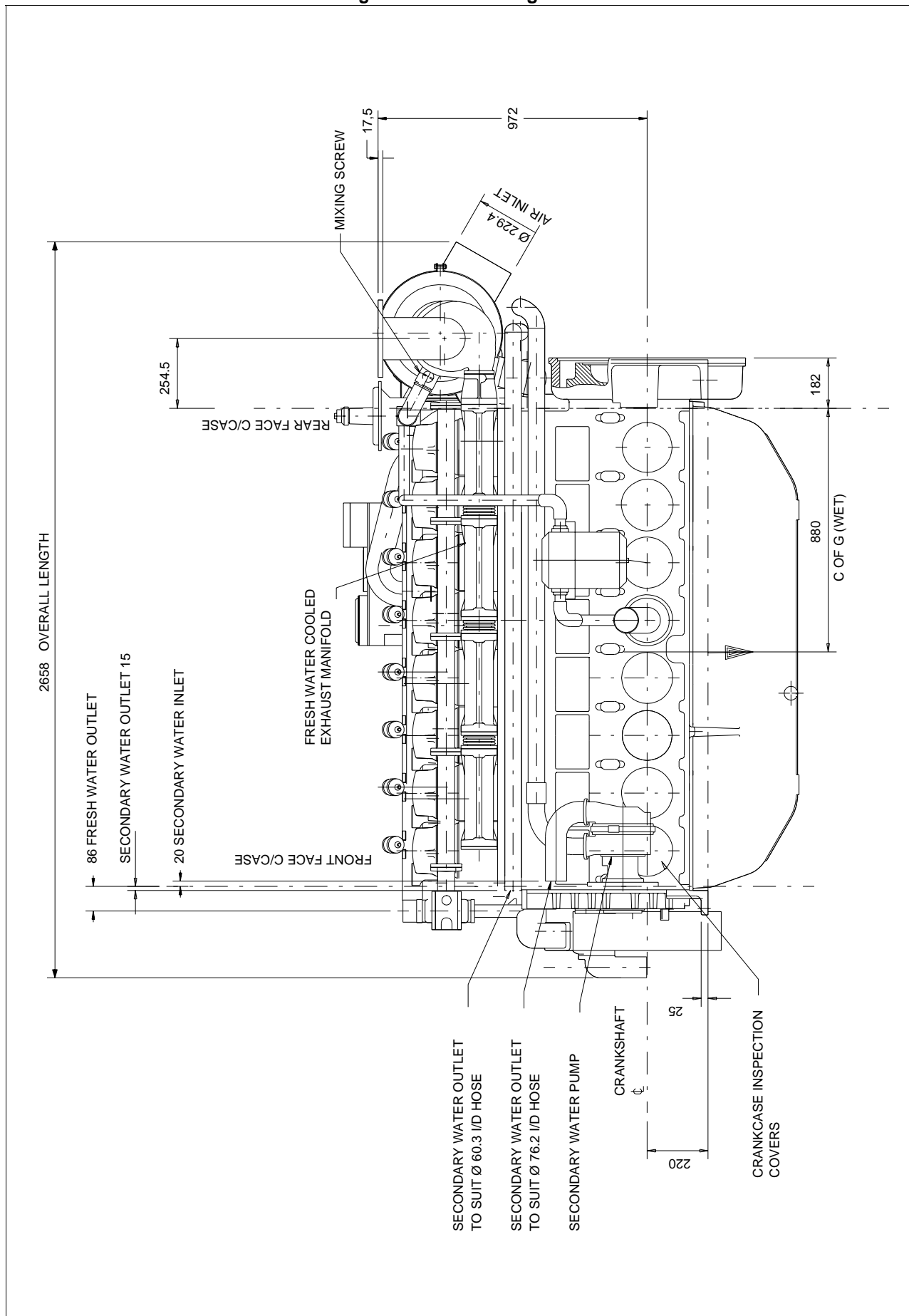

4008-30TRS1 and 4008-30TRS2 Natural gas electro unit - Rear view

EXHAUST OUTLET SYSTEM PIPEWORK
MUST BE ADEQUATELY SUPPORTED
TO ENSURE NO LOAD IS EXERTED
ON TURBOCHARGER. (SEE DETAIL)

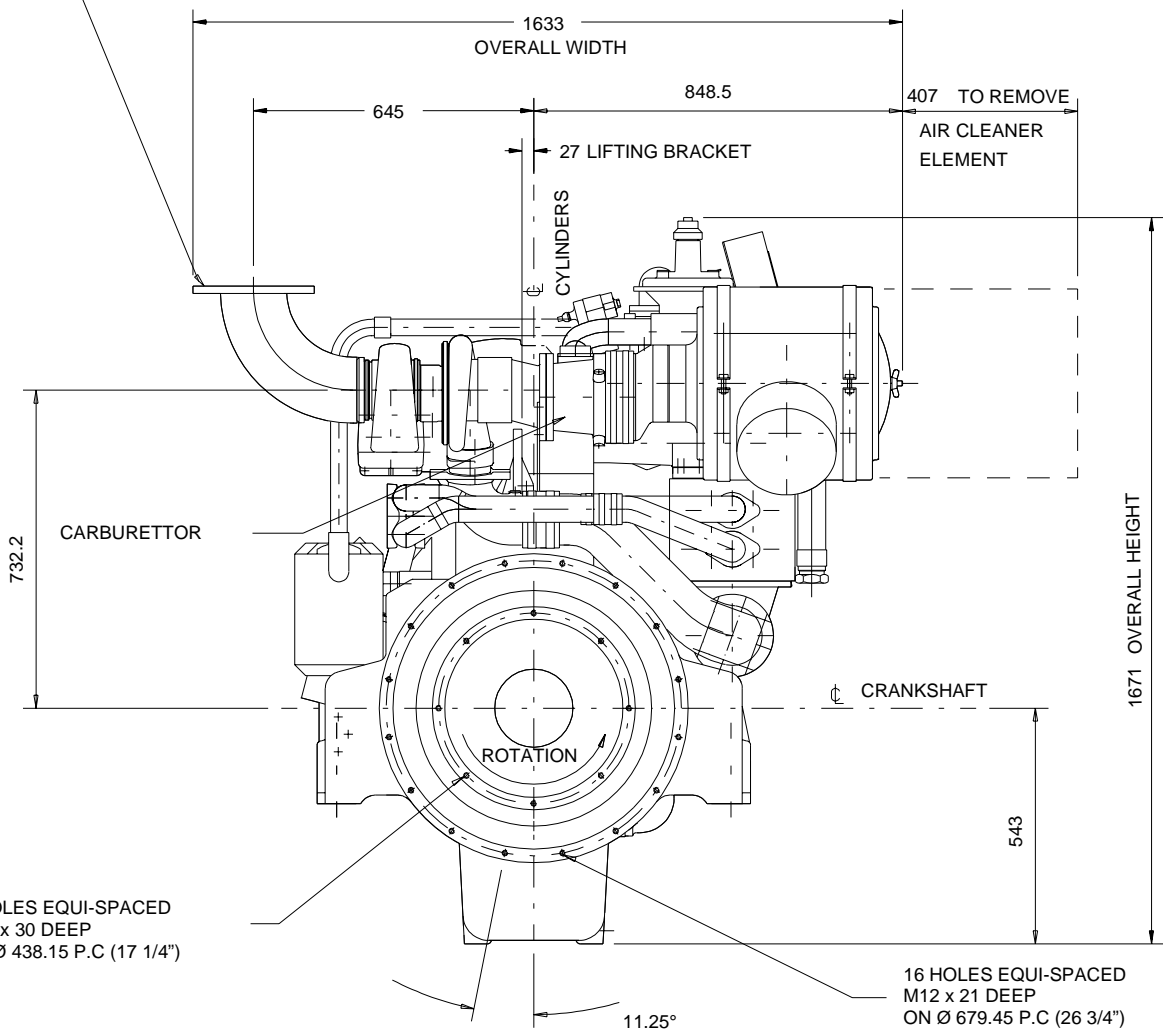

4008-30TRS1 and 4008-30TRS2 Natural gas electro unit - SAE Flywheel, Exhaust Outlet and Support Pads

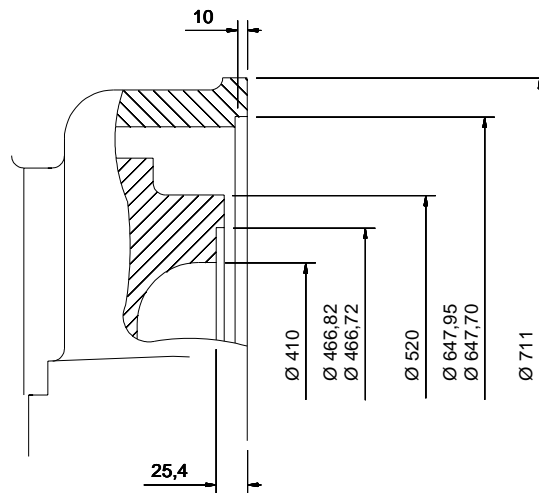

DETAIL OF SAE 514 FLYWHEEL
AND SAE O FLYWHEEL HOUSING
(METRIC TAPPINGS)
SCALE 1:5

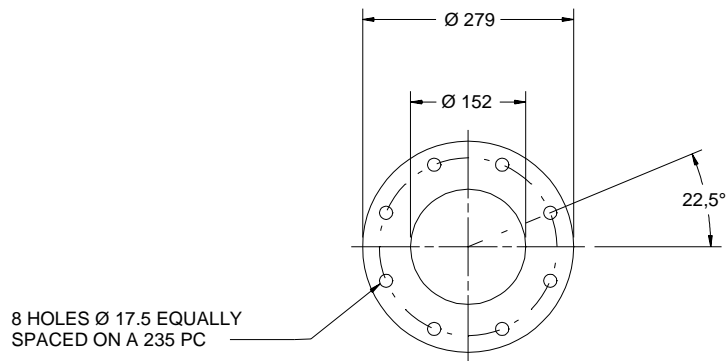

8 HOLES Ø 17.5 EQUALLY
SPACED ON A 235 PC

DETAIL OF EXHAUST OUTLET
SCALE 1:5

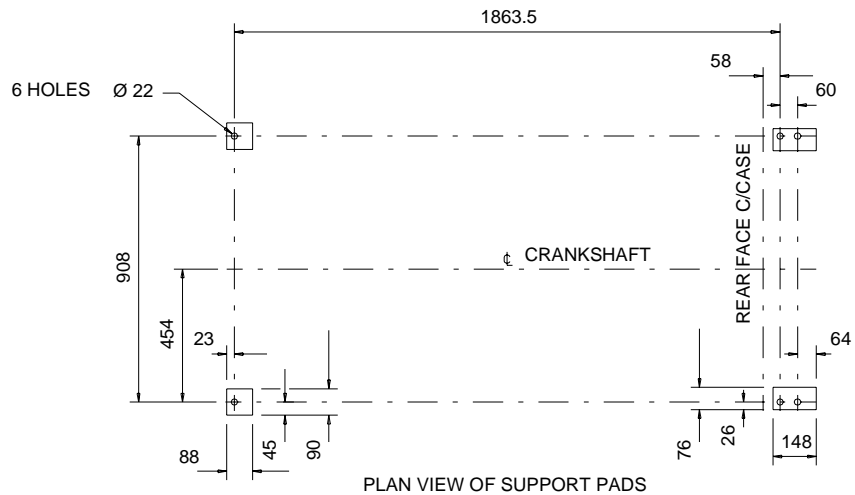

PLAN VIEW OF SUPPORT PADS

Derate tables

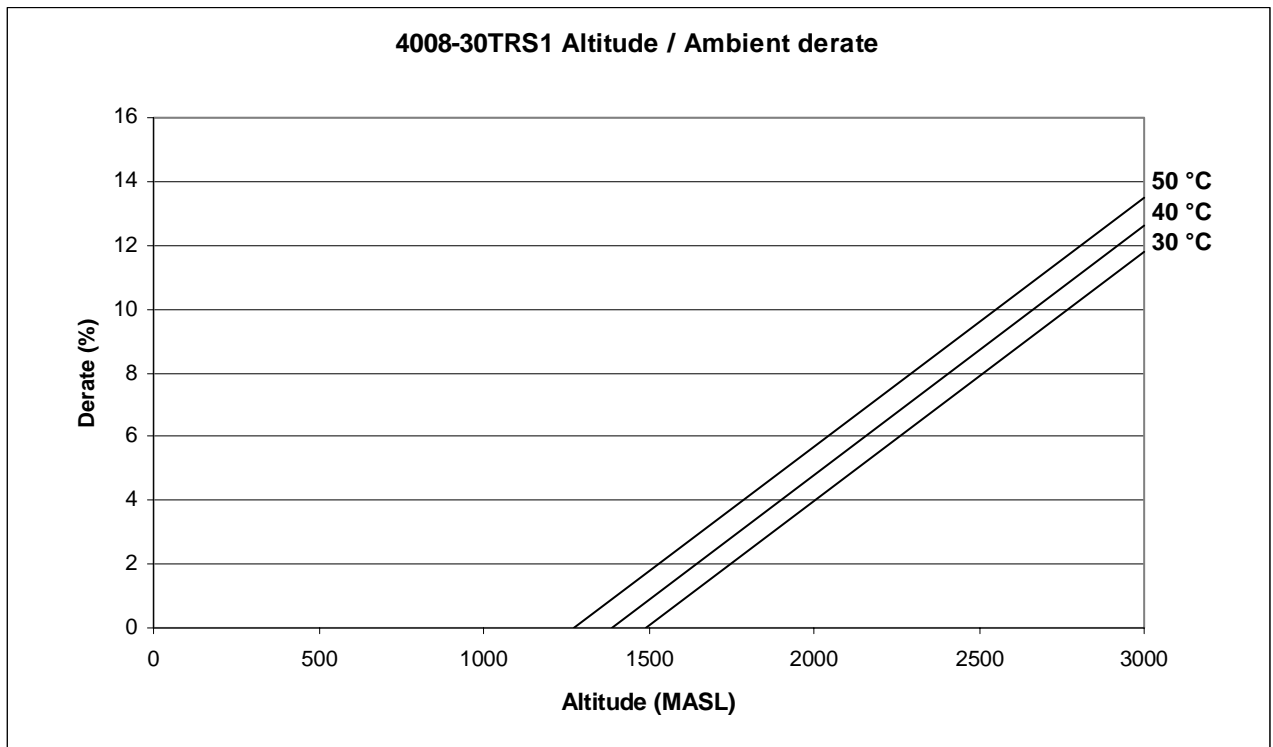
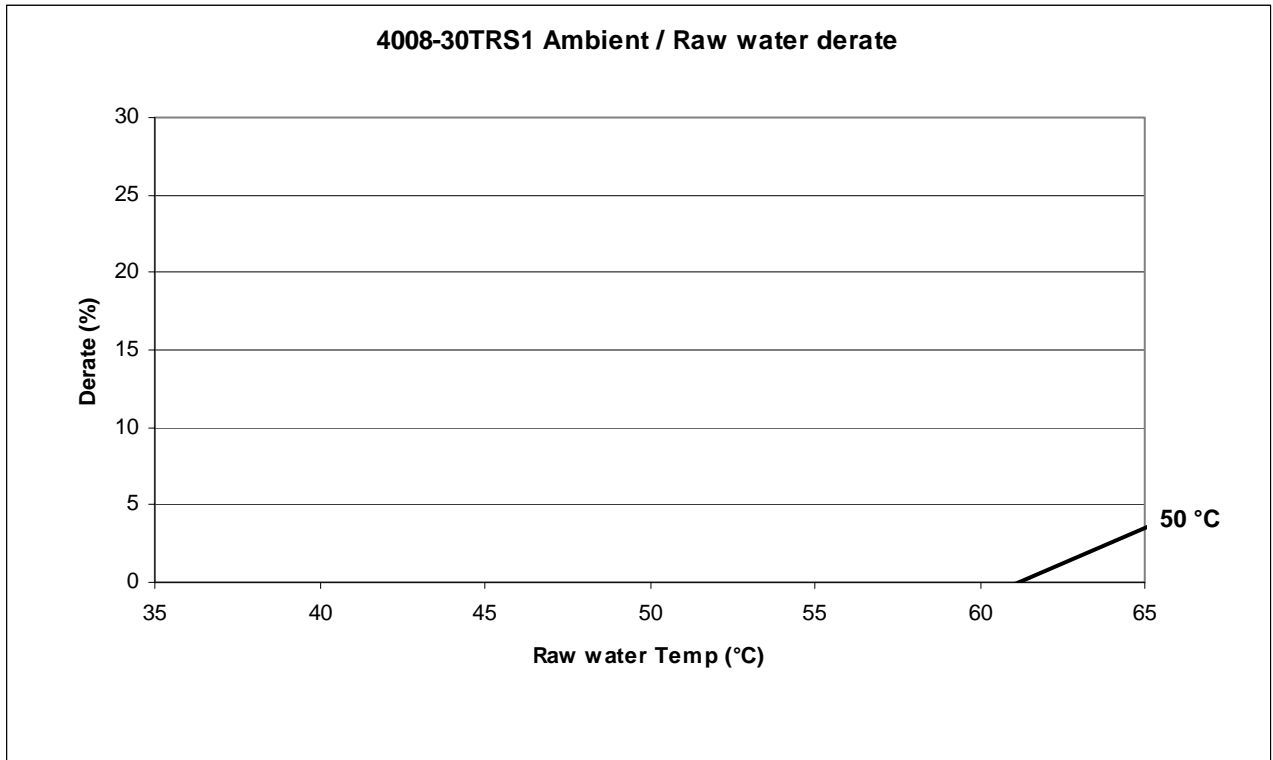

4008-30TRS2 Ambient / Raw water derate

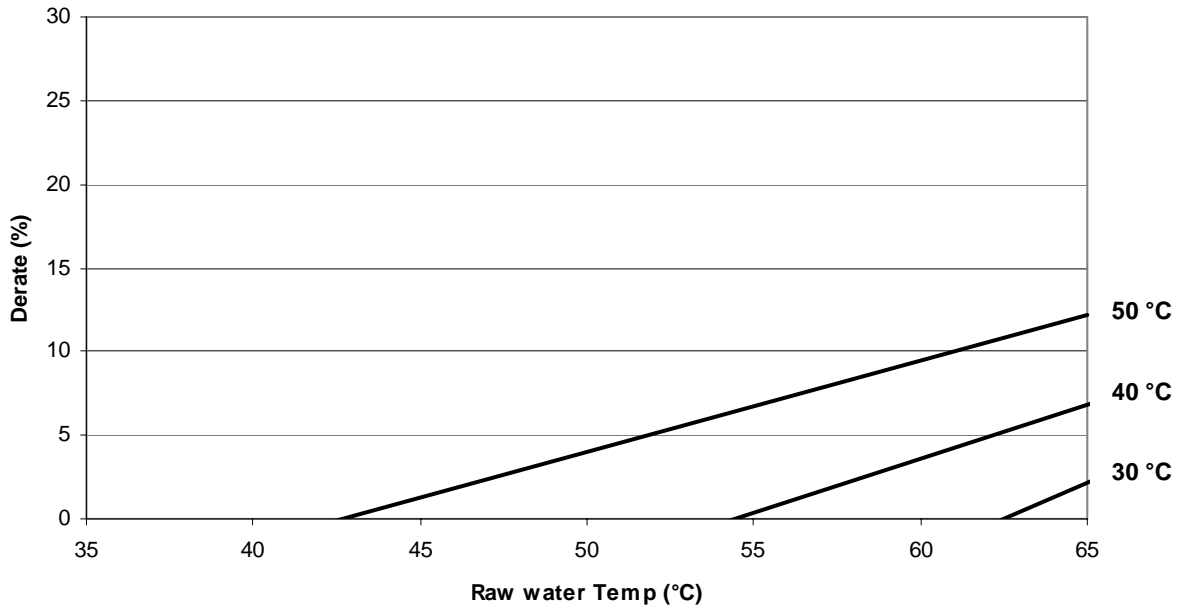

4008-30TRS2 Altitude / Ambient derate

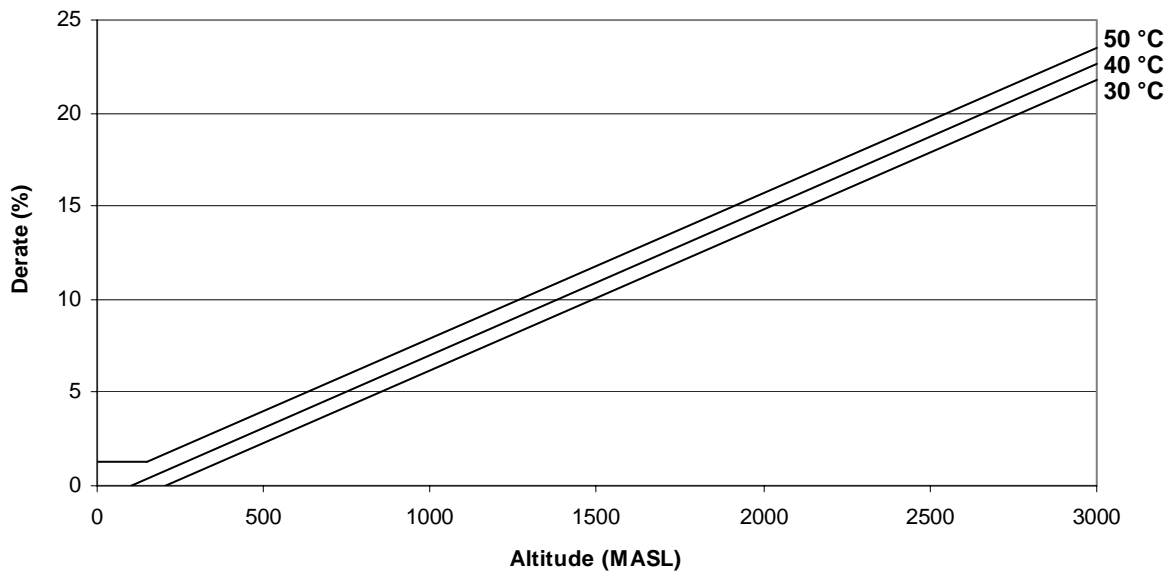

Induction system

Maximum air intake restriction of engine:

-clean filter	127 mm H ₂ O
-dirty filter	380 mm H ₂ O
-air filter type	1 off dry type

Exhaust emissions data

Ambient temperature of 25 °C

Emissions at continuous baseload rating.

If the engine is to operate in ambient conditions other than test conditions then suitable adjustments may be necessary for any change in inlet air temperature or barometric pressure.

Designation		TRS1	TRS2
		1500 rev/min	
Oxygen (O ₂)	%	9,01	9,24
*Oxides of Nitrogen (NOx)	mg/Nm ³	480	490
*Hydrocarbons (THC)	mg/Nm ³	1160	1100
*Carbon Monoxide (CO)	mg/Nm ³	791	774

Designation		Cogeneration unit		Electro unit	
		TRS1	TRS2	TRS1	TRS2
Mass flow data		1500 rev/min			
Combustion air (25 °C)	kg/h	2385	2766	2416	2802
Volume flow data					
Combustion air (25 °C)	m ³ /h	2040	2366	2067	2397

Exhaust system

Designation		TRS1	TRS2
Maximum back pressure for total system	Units	1500 rev/min	
	mm H ₂ O	600	400

Exhaust outlet flange size

For recommended pipe sizes see the Installation Manual.

Designation		Cogeneration unit		Electro unit	
		TRS1	TRS2	TRS1	TRS2
Volume flow data (100 kPa)	Units	1500 rev/min			
Exhaust gas (at turbo exit temperature)	m ³ /h	5409	6215	5481	6296

Designation		TRS1	TRS2
Exhaust data	Units	1500 rev/min	
Exhaust temperature	°C	487	478
Oxygen content in exhaust gas	%	9,01	9,24
Lambda	λ	1,71	1,70

Starting requirements

Temperature range		
Down to 0 °C (32 °F)	Oil:	Refer to Perkins Engines Company Limited
	Starter:	1 x 24 volts
	Battery:	2 x 12V Total Ah 232
	Inrush current to starter:	1000 amps
	Cranking current:	600 amps
	Starter cable size:	70 mm ²
	Maximum length:	6 m

Notes:

- Engines **not** equipped with additional A:F ratio control will require immersion heaters to be fitted when ambient temperatures are below 15 °C
- Engines fitted with additional A:F ratio control with start unaided down to 0 °C
- The battery capacity is defined by the 20 hour rate
- The starting ability of an engine with immersion heater will be improved by about 10 °C and the start aid specification can be modified accordingly. The oil specification should be for the minimum ambient temperature as the oil will not be warmed by the immersion heater
- Breakaway current is dependant on battery capacity available. Cables should be capable of handling the transient current which may be up to double the steady cranking current.

Electrical system

Type	Insulated return
Starter motor	24 volts
Starter motor power	7,5 kW
Number of teeth on flywheel	190
Number of teeth on starter motor	12
Minimum cranking speed	120 rev/min
Pull in current of starter motor solenoid	26,8 amps at 24 volts
Hold in current of starter motor solenoid	9 amps at 24 volts

Ignition system

Primary system	Altronic Disn 800
Primary voltage	24 volts
Polarity	Negative earth
Spark plug gap	0,25 mm
Ignition timing	24° BTDC

4000 Series

Noise levels

The figures for total noise levels are typical for an engine running at the continuous baseload power rating in a semi-reverberant environment and measured at a distance of one metre from the periphery of the engine (sound pressure level re: -20×10^{-6} pa).

Speed. 1500 rev/min
 Ambient noise level 70 dBA

4008-30TRS1 432 kWb 1500 rev/min

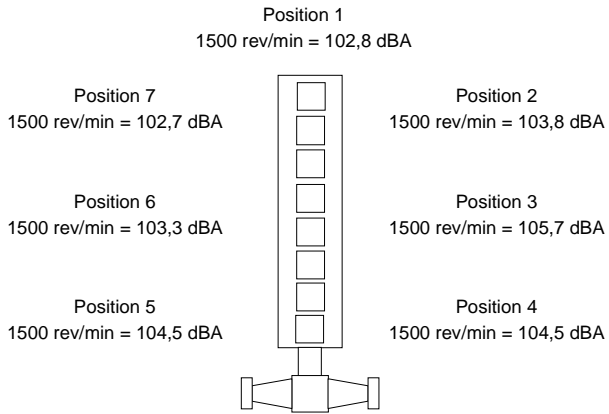

4008-30TRS2 526 kWb 1500 rev/min

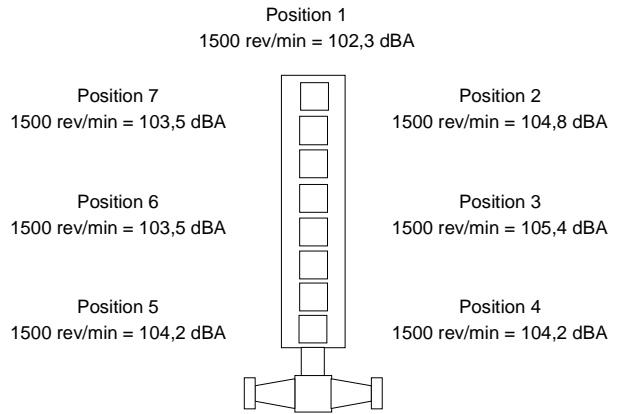

Engine mounting

Maximum additional load applied to flywheel due to all rotating components ... 650 kg

The information given on this Technical Data Sheet are for guidance only.

For ratings other than those shown, please contact Perkins Engines Company Limited.

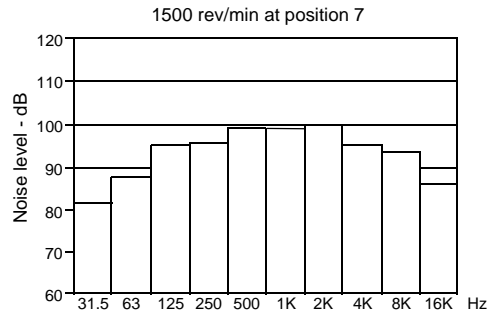

Distributed by