

BFM 1015

Deutz BF8M 1015CP for generator sets 250 - 517 kW|
335 - 693 hp at 1500/1800 min⁻¹|rpm EU Stage II / US EPA Tier 2

- Water-cooled V6 and V8 engines with turbocharging, charge air cooling and four-valve technology.
- Also available with an electronic motor regulator (EMR) to allow easy integration into the electronic device control and monitoring system.
- The robust engine design allows worldwide operation even with high sulphur fuels.



- Low noise emissions due to acoustically optimized components with very smooth running and high durability.
- Robust and reliable mechanical injection system.
- Best cold starting performance even under extreme conditions.
- A very good load response ensures an immediate power supply.

Technical data

Engine type		BF6M 1015C	BF6M 1015CP	BF8M 1015C	BF8M 1015CP
No. of cylinders		6	6	8	8
Bore/stroke	mm in	132/145 5.2/5.7	132/145 5.2/5.7	132/145 5.2/5.7	132/145 5.2/5.7
Displacement	l cu in	11.9 727	11.9 727	15.9 969	16 969
Weight (incl. cooler and fan)	kg lb	1020 2249	1055 2326	1265 2789	1300 2866
Governing standard ¹⁾		G2	G2	G2	G2

50 Hz / 1500 rpm

Power		BF6M 1015C	BF6M 1015CP	BF8M 1015C	BF8M 1015CP
Continuous Power (COP) ²⁾	kW hp	285,0 382,2	303,0 406,3	372,0 498,9	399,0 535,1
Prime Power (PRP) ³⁾	kW hp	315,0 422,4	338,0 453,3	413,0 553,8	448,0 600,8
Limited Time Power (LTP) ⁴⁾	kW hp	345,0 462,7	365,0 489,5	459,0 615,5	490,0 657,1
Fan power consumption	kW hp	14,0 18,8 (LTP 8,7) (LTP 11.7)	8,7 11,7	8,7 11,7 (LTP 15,4) (LTP 20.7)	15,4 20,7
Typical Generator Output COP ⁵⁾	kVA	315	339	422	446
Typical Generator Output PRP ⁵⁾	kVA	350	383	470	503
Typical Generator Output LTP ⁵⁾	kVA	391	414	516	552

1) According to ISO 8528-5.

2) Continuous Power: No time limitation, plus 10% additional power for governing purpose only.

3) Prime Power: Average power output ≤ 80%, no time limitation, plus 10% additional power for governing purpose only.

4) Limited Time Running Power: For up to 500 h/year, thereof a maximum of 300 h/year continuous running.

5) In consideration of a generator efficiency level of 92 - 93 % and a power factor of 0.8..

The data on this data sheet are for information purposes only and are not binding values.
The data in the quotation is definitive.

The engine company.



50 Hz / 1500 rpm

Fuel Consumption (PRP) ¹⁾		BF6M 1015C	BF6M 1015CP	BF8M 1015C	BF8M 1015CP
Fuel consumption 25% load	g/kWh lb/hph	215 0.35	219 0.36	216 0.36	220 0.36
Fuel consumption 50% load	g/kWh lb/hph	203 0.33	208 0.34	203 0.33	209 0.34
Fuel consumption 75% load	g/kWh lb/hph	203 0.33	208 0.34	203 0.33	211 0.35
Fuel consumption 100% load	g/kWh lb/hph	207 0.34	215 0.35	208 0.34	220 0.36

Heat balance & cooling system		BF6M 1015C	BF6M 1015CP	BF8M 1015C	BF8M 1015CP
Heat dissipation (engine radiator) ²⁾	kW hp	157 211	166 223	216 290	250 335
Heat dissipation (CAC) ²⁾	kW hp	77 103	85 114	105 141	114 153
Heat dissipation (convection)	kW hp	28 38	30 40	37 50	40 54
Cooling air flow	m ³ /h cfm	21960 12925	21960 12925	29520 17375	29880 17587

Inlet & exhaust data		BF6M 1015C	BF6M 1015CP	BF8M 1015C	BF8M 1015CP
max. intake depression	mbar psi	50 0.73	50 0.73	50 0.73	50 0.73
Combustion air volume	m ³ /h cfm	1339 788	1386 816	1777 1046	1848 1088
max. exhaust gas temperature	°C °F	520 968	555 1031	540 1004	560 1040
Exhaust gas flow	m ³ /h cfm	3644 2145	4000 2354	4822 2838	5357 3153

1) Refers to diesel with a density of 0.835 kg/dm³ at 15°C | 6.96 lb/US gallon at 60°F.

2) The heat quantities are valid for the dimensioning of the cooling system.

Dimensions

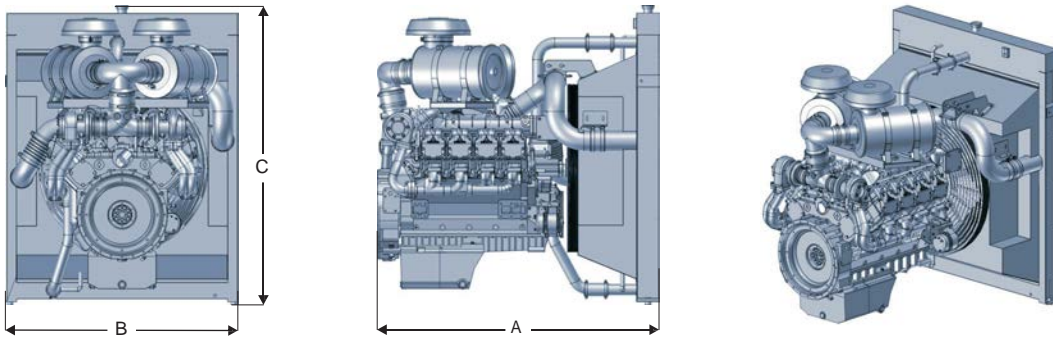

		A	B	C
BF6M 1015C	mm in	1635 64	1315 52	1865 73
BF6M 1015CP	mm in	1635 64	1515 60	1925 76
BF8M 1015C	mm in	1750 69	1515 60	1740 69
BF8M 1015CP	mm in	1750 69	1815 71	1850 73

Note: The engine dimensions and weights vary depending on the scope of delivery.

<http://www.brizmotors.ru/equipment/ctm/deutz-510/>

