

VOLVO PENTA GENSET ENGINE

TAD1242GE

1500 rpm, 387 kW (526 hp) – 1800 rpm, 430 kW (585 hp)

The TAD1242GE is a powerful, reliable and economical Generating Set Diesel Engine built on the dependable in-line six design.

Durability & low noise

Designed for easiest, fastest and most economical installation. Well-balanced to produce smooth and vibration-free operation with low noise level.

To maintain a controlled working temperature in cylinders and combustion chambers, the engine is equipped with piston cooling. The engine is also fitted with replaceable cylinder liners and valve seats/guides to ensure maximum durability and service life of the engine.

Low exhaust emission

The state of the art, high-tech injection and charging system with low internal losses contributes to excellent combustion and low fuel consumption.

The TAD1242GE complies with EU Stage 2 and TA-Luft -50% exhaust emission regulations.

Easy service & maintenance

Easily accessible service and maintenance points contribute to the ease of service of the engine.

Technical description:

Engine and block

- Optimized cast iron cylinder block with optimum distribution of forces without the block being unnecessarily heavy.
- Wet, replaceable cylinder liners
- Piston cooling for low piston temperature and reduced ring temperature
- Tapered connecting rods for reduce risk of piston cracking
- Crankshaft induction hardened bearing surfaces and fillets with seven bearings for moderate load on main and high-end bearings
- Case hardened and Nitrocarburized transmission gears for heavy duty operation
- Keystone top compression rings for long service life
- Viscous type crankshaft vibration dampers to withstand single bearing alternator torsional vibrations
- Replaceable valve guides and valve seats
- Over head camshaft and four valves per cylinder

Lubrication system

- Full flow oil cooler
- Full flow disposable spin-on oil filter, for extra high filtration
- The lubricating oil level can be measured during operation
- Gear type lubricating oil pump, gear driven by the transmission

Fuel system

- Non-return fuel valve
- Electronic Unit Injectors
- Fuel prefilter with water separator and water-in-fuel indicator / alarm
- Gear driven low-pressure fuel pump
- Fine fuel filter with manual feed pump and fuel pressure switch
- Fuel shut-off valve, electrically operated

Cooling system

- Efficient cooling with accurate coolant control through a water distribution duct in the cylinder block. Reliable sleeve thermostat with minimum pressure drop

- Gear driven, maintenance-free coolant pump with high degree of efficiency
- Coolant filter as standard

Turbo charger

- Efficient and reliable turbo charger
- Extra oil filter for the turbo charger

Electrical system

- Electronical Diesel Control III (EDCIII), an electronically controlled processing system which optimizes engine performance. It also includes advanced facilities for diagnostics and fault tracing
- Three different ways for the customer to connect his controls and instrument to the engine. CAN SAE J1939 interface, CIU (Control interface unit) and Stand alone connections.
- Sensors for oil pressure, oil temp, boost pressure, boost temp, coolant temp, fuel temp, water in fuel, fuel pressure and two speed sensors.



Features

- Maintained performance, air temp 40°C
- Cooling system (55°C)
- Fully electronic with Volvo Penta EDC III
- Dual frequency switch (between 1500 rpm and 1800 rpm)
- High power density
- Emission compliant
- Low noise levels
- Gen Pac configuration

TAD1242GE

Technical Data

General

Engine designation	TAD1242GE	
No. of cylinders and configuration	in-line 6	
Method of operation	4-stroke	
Bore, mm (in.)	131 (5.16)	
Stroke, mm (in.)	150 (5.91)	
Displacement, l (in ³)	12.13 (740.2)	
Compression ratio	17.5:1	
Dry weight, kg (lb)	1380 (3036)	
With Gen Pac, kg (lb)	1645 (3627)	
Wet weight, kg (lb)	1455 (3201)	
With Gen Pac, kg (lb)	1720 (3792)	

Performance

	1500 rpm	1800 rpm
kW (hp)	352 (479)	391 (532)
Prime Power	352 (479)	391 (532)
Max Standby Power	387 (526)	430 (585)

Lubrication system

	1500 rpm	1800 rpm
Oil consumption, liter/h (US gal/h)	0.12 (0.032)	0.14 (0.037)
Prime Power	0.12 (0.032)	0.14 (0.037)
Max Standby Power	0.14 (0.037)	0.15 (0.040)
Oil system capacity incl filters, liter	35	
Oil change intervals at specification		
VDS-2, h	600	
VDS, ACEA E3, h	400	
ACEA E1, E2, API CD, CF, CF-4, CG-4, h	200	

Fuel system

	1500 rpm	1800 rpm
Specific fuel consumption at Prime Power, g/kWh (lb/hph)	216 (0.350)	231 (0.374)
25 %	199 (0.323)	208 (0.330)
50 %	195 (0.316)	200 (0.324)
75 %	198 (0.321)	202 (0.327)
100 %	211 (0.347)	225 (0.365)
Max Standby Power, g/kWh (lb/hph)	197 (0.319)	203 (0.329)
25 %	195 (0.316)	200 (0.324)
50 %	199 (0.323)	203 (0.329)
75 %		
100 %		

Intake and exhaust system

	1500 rpm	1800 rpm
Air consumption at 27°C, m ³ /min (cfm)	23.5 (830)	28.0 (989)
Prime Power	23.5 (830)	28.0 (989)
Max Standby Power	25.0 (883)	29.0 (1024)
Max allowable air intake restriction, kPa (In wc)	5 (20.1)	
Heat rejection to exhaust, kW (BTU/min)	250 (14217)	272 (15468)
Prime Power	250 (14217)	272 (15468)
Max Standby Power	276 (15696)	306 (17402)
Exhaust gas temperature after turbine, °C (°F)	490 (914)	465 (869)
Prime Power	490 (914)	465 (869)
Max Standby Power	505 (914)	490 (914)
Max allowable back-pressure in exhaust line, kPa (In wc)	10 (40.2)	
Exhaust gas flow, m ³ /min (cfm)	58 (2048)	66 (2331)
Prime power	58 (2048)	66 (2331)
Max Standby Power	63 (2225)	72 (2543)

Cooling system

	1500 rpm	1800 rpm
Heat rejection radiation from engine, kW (BTU/min)	17 (967)	18 (1024)
Prime Power	17 (967)	18 (1024)
Max Standby Power	18 (1024)	20 (1137)
Heat rejection to coolant kW (BTU/min)	123 (6995)	139 (7905)
Prime Power	123 (6995)	139 (7905)
Max Standby Power	125 (7109)	143 (8132)
Fan power consumption, kW (hp)	9 (12)	15 (20)

Note! Not all models, standard equipment and accessories are available in all countries. All specifications are subject to change without notice. The engine illustrated may not be entirely identical to production standard engines.

Power Standards

The engine performance corresponds to ISO 3046, BS 5514 and DIN 6271. The technical data applies to an engine without cooling fan and operating on a fuel with calorific value of 42.7 MJ/kg (18360 BTU/lb) and a density of 0.84 kg/liter (7.01 lb/US gal), also where this involves a deviation from the standards. Power output guaranteed within 0 to +2% at rated ambient conditions at delivery. Ratings are based on ISO 8528. Engine speed governing in accordance with ISO 3046/IV, class A1 and ISO 8528-5 class G3

Exhaust emissions

The engine complies with EU stage 2 emission legislation according to the Non Road Directive EU 97/68/EEC. The engine also complies with TA-luft -50% exhaust emission regulations.

Rating Guidelines

PRIME POWER rating corresponds to ISO Standard Power for continuous operation. It is applicable for supplying electrical power at variable load for an unlimited number of hours instead of commercially purchased power. A10 % overload capability for governing purpose is available for this rating. MAXIMUM STANDBY POWER rating corresponds to ISO Standard Fuel Stop Power. It is applicable for supplying standby electrical power at variable load in areas with well established electrical networks in the event of normal utility power failure. No overload capability is available for this rating. 1 hp = 1 kW x 1.36

Information

For more technical data and information, please look in the Generating Set Engines Sales Guide.

Standard equipment

Engine

Automatic belt tensioner

Lift eyelets

Flywheel

Flywheel housing with conn. acc. to SAE 1

Flywheel for 14" flex. plate and flexible coupling

Vibration dampers

Engine suspension

Fixed front suspension

Lubrication system

Oil dipstick

Full-flow oil filter of spin-on type

By-pass oil filter of spin-on type

Oil cooler, side mounted

Low noise oil sump

Fuel system

Fuel filters of disposable type

Electronic unit injectors

Pre-filter with water separator

Intake and exhaust system

Air filter with replaceable paper insert

Air restriction indicator

Air cooled exhaust manifold

Connecting flange for exhaust pipe

Exhaust flange with v-clamp

Turbo charger, low right side

Crankcase ventilation

Cooling system

Radiator incl intercooler

Gear driven coolant pump

Fan hub

Thrust fan

Fan guard

Belt guard

Control system

Engine Management System (EMS) with

CAN-bus interface SAE J1939 and stand alone

interface

Alternator

Alternator 60A / 24 V

Starting system

Starter motor, 6.0kW, 24 V

Connection facility for extra starter motor

Instruments and senders

Temp.- and oil pressure for automatic

stop/alarm 103°C

Other equipment

Expandable base frame

Engine Packing

Plastic warpping

¹⁾ must be ordered, see order specification - optional equipment

- optional equipment or not applicable

• included in standard specification

Dimensions TAD1242GE

Not for installation

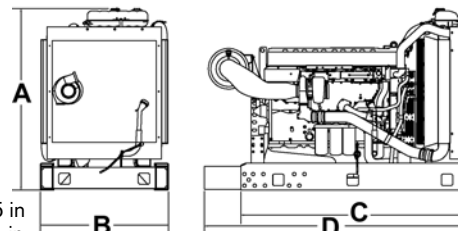

A* = 1587 mm / 62.5 in

B* = 1120 mm / 44.1 in

C* = 1976 mm / 77.8 in

D = 2296 mm / 90.5 in (During transport)

D = Max 3311 mm / 130.5 in

*Incl. radiator and intercooler

VOLVO PENTA

<http://www.brizmotors.ru/equipment/ctm/v400/>

Design and operation

System description EDC III

EDC III, "Electronic Diesel Control", is an electronic system with CAN communication for diesel engine management. The system is developed by Volvo Penta and covers fuel management, diagnostic function, etc. The system consists of a control module, six unit injectors, a number of sensors that provide information to the control module, and a data link connector for diagnostics and functionality checks. The EDC III system also has a "stand alone" interface that can be linked directly to the engine control module on the engine. The engine can be linked to a "CAN" interface and a "Control Interface Unit" (CIU), which is an interface to the operator area.

Control module

The EDC III system processor is located in the control module, protected from moisture and vibrations.

The processor continually receives information regarding:

- Engine speed
- Charge air pressure
- Charge air temperature
- Coolant temperature
- Oil pressure
- Oil temperature
- Fuel alarm, combined alarm for "water in fuel" and "fuel pressure"
- Coolant level

This information is used to make exact determinations on current operating conditions and allows the processor to calculate the correct amount of fuel, check the condition of the engine, etc.

Fuel management

The engine's fuel need is analyzed up to 100 times per second (depending on engine speed). The quantity and timing of fuel injection into the engine are controlled completely electronically via fuel valves on the unit injectors.

This means that the engine always receives the correct amount of fuel under all operating conditions, providing benefits including improved fuel economy and minimized exhaust emissions.

The control module checks and controls the unit injectors so that the correct amount of fuel is injected into each cylinder. It calculates and sets the injection angle. This control is done primarily with the help of the tachometer sensors and the combined sensor for charge air pressure/temperature.

The control module actuates the unit injectors via an electronic signal to the unit injectors' electromagnetically controlled fuel valve, which can then be opened or closed.

When the fuel valve is open, fuel streams by, through the unit injector holes and out through the fuel channel. Fuel is not injected into the cylinder at this stage.

When the fuel valve is closed, pressure is built up by the mechanically driven pump piston of the unit injector. Once enough pressure is built up, fuel is injected into the cylinder via the injector portion.

The fuel valve is reopened and pressure in the unit injector sinks while fuel injection to the cylinder ceases.

To determine when the fuel valve should be opened or closed, the control module has access to signals from sensors and switches.

Calculation of fuel quantity

The amount of fuel injected into a cylinder is calculated by the control module. The calculation gives the amount of time the fuel valve is closed (as fuel is injected into the cylinder when the fuel valve is closed). The parameters that determine the amount of fuel injected are:

- Requested RPM
- Engine protection functions
- Temperature
- Charge air pressure

Cylinder balance

When idling, the control module can provide the cylinders with different amounts of fuel. This makes the engine idle more evenly. At higher RPM, all cylinders receive an equal amount of fuel.

Diagnostic function

The EDC III system has an internal diagnostic function that makes it possible to detect faults in the engine and sensor.

The role of the diagnostic function is to detect and localize disruptions in the EDC III system, protect the engine and ensure that the machine remains in working order during serious disturbances.

If a disturbance arises, the diagnostic indicator on the indicator panel begins blinking. When the diagnosis button is pressed, an error code is given as guidance for any fault detection. The diagnostic function can be read out via the display using the PC diagnostics program.

Idle adjustment (low idle)

Idle can be adjusted to a value between 600 and 1200 RPM.

Component description

The digits after the headings refer to "Component diagram and location".

Water monitor, fuel pre-filter (19)

The monitor is located on the bottom of the fuel pre-filter.

Its role is to guard against water in the fuel system. The monitor consists of two copper pins between which resistance is measured. When resistance falls below the limit value, which indicates that there is water in the fuel, a warning signal is sent to the control module.



Tachometer sensor, camshaft (2)

The tachometer sensor is located on the upper timing cover. The tachometer sensor, which is linked to the camshaft, is an inductive sensor. It reads a toothed wheel with seven pins. The impulses from the camshaft sensor provide the control module information on which cylinder is next in line for injection and when it receives it.



Oil pressure/temperature sensor (10)

Oil pressure and oil temperature are measured by a combined sensor that is located on the left-hand side of the engine, next to the control module.

The sensor is mounted in the engine block so that measurement is taken from the oil system's main channel. The sensor consists of a non-linear resistor whose resistance is dependant on the temperature of the resistor body. Resistance decreases as temperature increases. The pressure signal is a voltage signal proportional to the pressure. The reference voltage for the sensor is 5 Volts.



Tachometer sensor, flywheel (18)

This sensor is located on the left-hand side of the flywheel housing.

The tachometer sensor on the flywheel is an inductive sensor. It reads the crankshaft position and engine speed using grooves in the flywheel. The signal is sent to the control module, which calculates the injection angle and amount of fuel.



Charge air pressure/temperature sensor (6)

Charge air pressure and charge air temperature are measured with a combined sensor located on the intake manifold.

The charge air pressure sensor measures absolute pressure, which is the sum of the charge air pressure and atmospheric pressure. The sensor sends a signal to the control module in the form of voltage that is proportional to the absolute pressure. The sensor receives a reference voltage of 5 Volts from the control module.

The charge air temperature sensor consists of a non-linear resistor whose resistance depends on the temperature of the resistor body. Resistance decreases as temperature increases.



Coolant temperature sensor (15)

The sensor is located on the left-hand rear portion of the cylinder head.

The sensor reads the temperature of the engine coolant and sends the information to the control module. It consists of a non-linear resistor whose resistance depends on the temperature of the resistor body. Resistance decreases as temperature increases.



Fuel pressure monitor (12)

The monitor is located on the left-hand side of the engine, mounted in the fuel filter bracket.

Its task is to detect if the fuel pressure falls below 29 psi (2 BAR). The monitor is set to shut off when pressure falls below 29 psi (2 BAR).

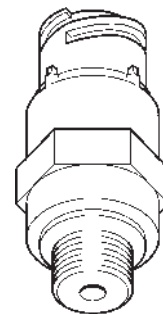

Coolant level monitor (1)

This monitor is located in the expansion tank.

Its task is to detect if the coolant level in the cooling system (expansion tank) is too low. The monitor consists of a contact that can be actuated magnetically. A hull located around the monitor actuates the contact differently depending on the coolant level. An alarm signal is sent if the coolant level is too low.

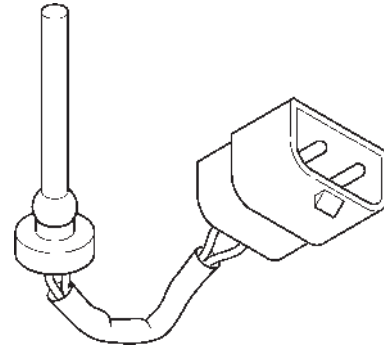

Electronic Control Unit (ECU) (11)

The control module (EMS) checks and controls the unit injectors so that the correct amount of fuel is injected into each cylinder. It calculates and sets the injection angle. This control is done primarily with the help of the tachometer sensors and the combined sensor for charge air pressure/temperature.

The EDC III system processor is located in the control unit, protected from moisture and vibrations.

The processor continually receives information regarding:

- engine speed
- charge air pressure
- charge air temperature
- coolant temperature
- oil pressure
- oil temperature
- fuel alarm, combined alarm for "water in fuel" and "fuel pressure"
- coolant level

This information is used to make exact determinations on current operating conditions and allows the processor to calculate the correct amount of fuel, check the condition of the engine, etc.

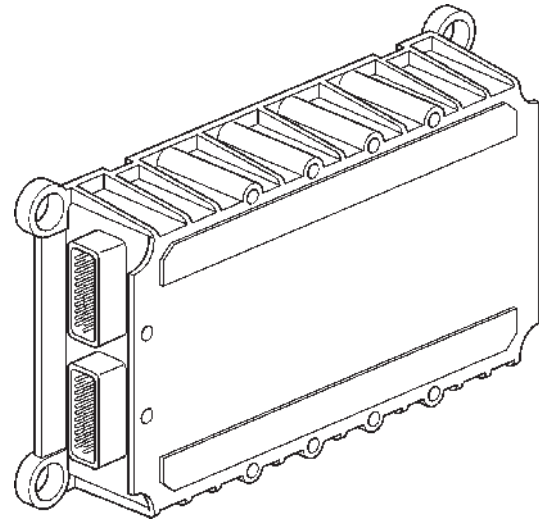

Control Interface Unit (CIU)

The CIU is a control unit that handles all interaction with the operator.

It communicates with the engine over two serial communication buses. J1939 is used for controlling and monitoring the engine. J1587 is used for diagnostics and backup.

The CIU loads a number of switches and speed requests and forwards them to the engine. It also controls four analogue instruments and up to nine warning lamps. Using a diagnosis button and diagnostic lamp, the operator can read out error codes from the system.

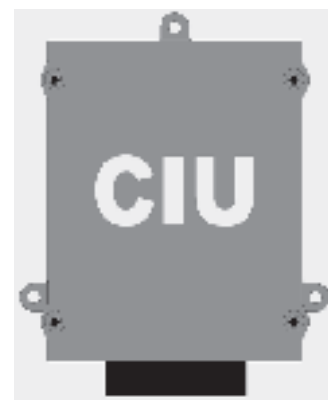

Unit injectors (20)

The unit injectors are located under the valve cover, mounted in the cylinder head.

The engine's fuel need is analyzed up to 100 times per second (depending on engine speed). The quantity and timing of fuel injection into the engine are controlled completely electronically via the unit injectors' electromagnetically operated fuel valves. This means that the engine always receives the correct amount of fuel under all operating conditions, providing benefits including improved fuel economy and minimized exhaust emissions.

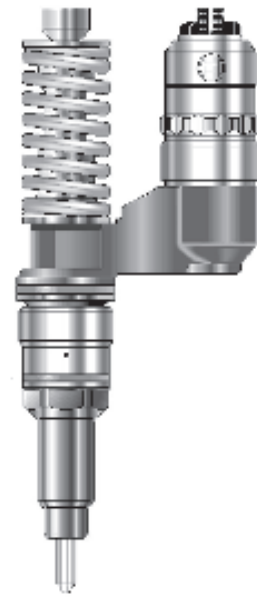

Generator (8)

The belt-driven generator is located on the left-hand front edge of the engine.

The voltage regulator of the generator is equipped with a sensor system. The sensor system compares the charging voltage between the generator connections, B+ and B-, with the actual voltage between the positive and negative poles of the batteries. The voltage regulator then compensates for any voltage drop in the lines between the generator and the battery by increasing the charging voltage from the generator as needed.

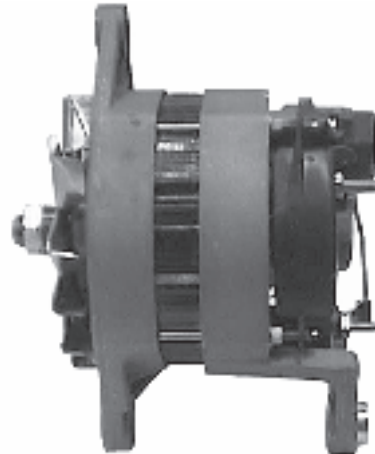

Starter motor (16)

The starter motor is mounted on the flywheel housing on the right-hand side of the engine.

When the motor is cut in, a gear on the armature shaft of the starter motor is moved along the axis so that it meshes with the gear ring of the engine's flywheel. The actuator solenoid of the starter motor controls both the axial movement of the gear and connection of the starter motor.

In turn, the actuator solenoid of the starter motor is cut in via the start relay, which is activated when the ignition key is turned to position III or the start button is depressed.

The starter motor relay (1) is mounted next to the starter motor solenoid.

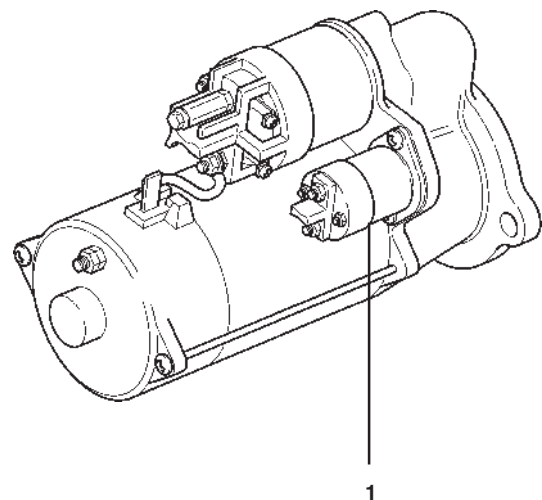

Component diagram and location

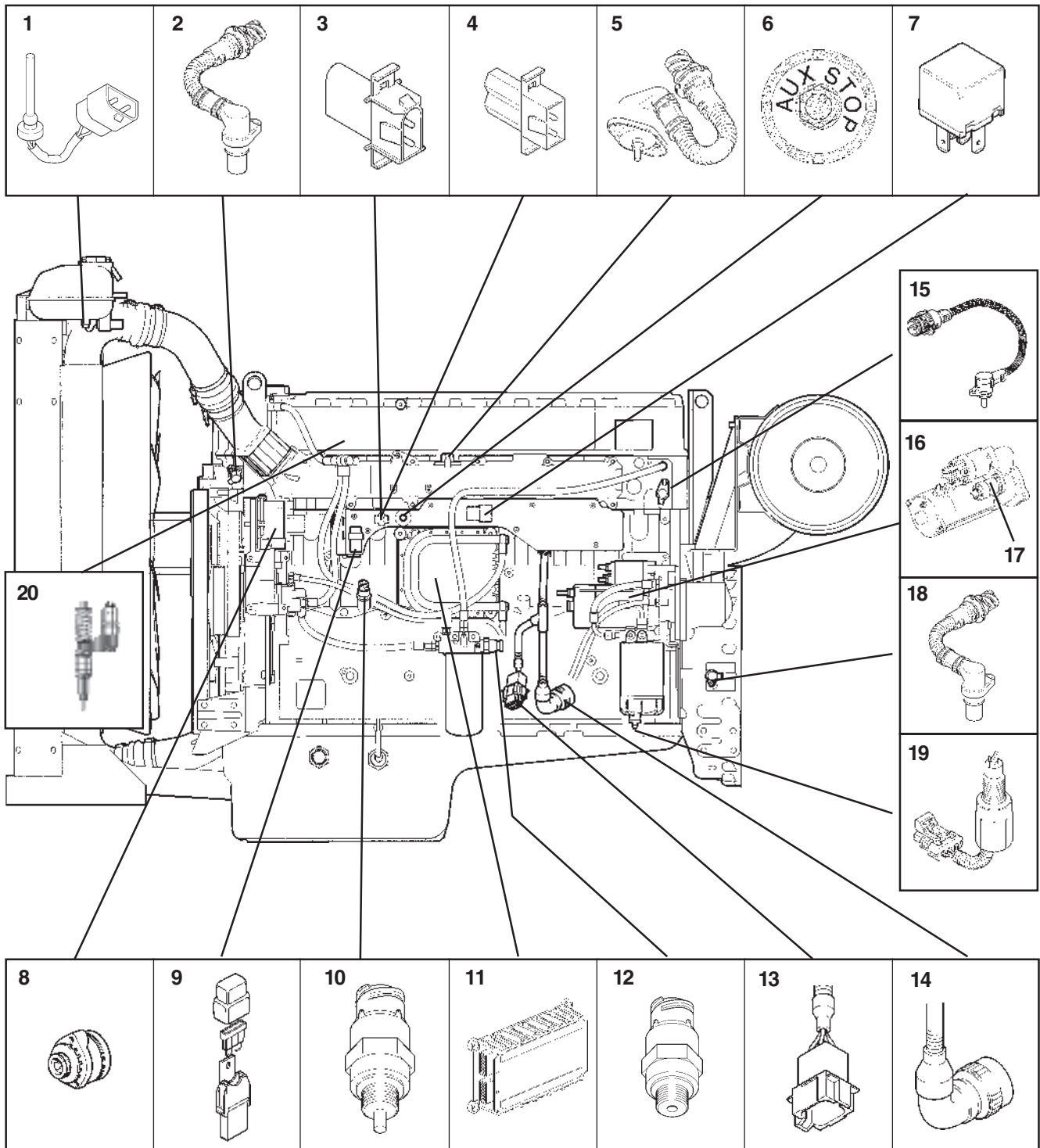

- | | |
|---|---------------------------------------|
| 1. Coolant level monitor | 11. Control unit (ECU) |
| 2. Tachometer sensor, camshaft | 12. Fuel pressure monitor |
| 3. Connection, diagnostic tool* | 13. 8-pin connection (Data bus) |
| 4. Programming plug* | 14. 23-pin connection (Stand alone) |
| 5. Charge air pressure/temperature sensor | 15. Coolant temperature sensor |
| 6. Extra stop | 16. Starter motor |
| 7. Main relay* | 17. Starter motor relay |
| 8. Generator | 18. Tachometer sensor, flywheel |
| 9. Fuse 10A | 19. Water monitor, fuel filter |
| 10. Oil pressure/temperature sensor | 20. Unit injectors (one per cylinder) |

* Inside the Cover

Limit values

Limit values, electronic control unit (ECU) TAD1240GE, TAD1241-42GE/VE

Alarm values

The maximum permissible values for charge air and coolant temperatures, for example, can be adjusted with the parameter setting tool and can thus vary within alarm limits.

If the alarm values are exceeded, the system reduces the amount of fuel until the value is once again within the permissible interval.

This function is a customer parameter that can be completely disengaged.

Alarm limits TAD1240–42GE/VE:

Coolant temperature:	Alarm lamp lights	Engine is switched off	Engine output 50%
Standard value Volvo Penta	98°C / 208°F	100°C / 212°F	
Parameter setting (can be set by the customer)	95–101°C / 203-214°F	+2°C / 36°F over the alarm value	

NOTE: Engine protection can be switched off.

Coolant level:

Alarm lamp lights when the contact is activated and the engine is switched off

Alarm switch is activated

NOTE: Engine protection can be switched off.

Charge air temperature:

Standard value Volvo Penta	83°C / 181°F	85°C / 185°F
----------------------------	--------------	--------------

NOTE: Engine protection can be switched off.

Oil pressure:

Standard value Volvo Penta	Idle: 0.7 bar (10,2 psi)	For oil pressure 0.3 bar (4,4 psi) lower than alarm value
	>1500 RPM: 2.5 bar (36,3 psi)	For oil pressure 0.3 bar (4,4 psi) lower than alarm value

NOTE: Engine protection can be switched off.

Oil temperature:

Standard value Volvo Penta	125°C / 257°F	127°C / 261°F
Parameter setting (can be set by customer)	120–130°C / 248-266°F	+2°C / 36°F over alarm value

NOTE: Engine protection can be switched off.

Fuel pressure:

Standard value Volvo Penta	<2 bar (<29 psi)	Engine not switched off
----------------------------	------------------	-------------------------

Monitor, water in fuel: Alarm lamp lights

RPM:

Standard value Volvo Penta Max. operational RPM + 20%

Activates upon operational RPM +15%.

Parameter setting (can be set by customer)

Max. operational RPM + 10–20%

NOTE: Engine protection is switched off as standard.

Limit values, electronic control unit (ECU) TWD1240VE

Alarm limits:

Coolant temperature:	Alarm lamp lights	Engine is switched off	Engine output 50%
Standard value Volvo Penta	98°C / 208°F	100°C / 212°F	
Parameter setting (can be set by the customer)	95–101°C / 203-214°F	+2°C / 36°F over the alarm value	

NOTE: Engine protection can be switched off.

Coolant level: Alarm lamp lights when the contact is activated and the engine is switched off

NOTE: Engine protection can be switched off.

Charge air temperature:

Standard value Volvo Penta	100°C / 212 °F	102°C / 216°F
----------------------------	----------------	---------------

NOTE: Engine protection can be switched off.

Oil pressure:

Standard value Volvo Penta	Idle: 0.7 bar (10,2 psi)	For oil pressure 0.3 bar (4,4 psi) lower than alarm value
	>1500 RPM: 2.5 bar (36,3 psi)	For oil pressure 0.3 bar (4,4 psi) lower than alarm value

* See diagram: "Oil pressure" below.

NOTE: Engine protection can be switched off.

Oil temperature:

Standard value Volvo Penta	125°C / 257°F	127°C / 261°F
Parameter setting (can be set by the customer)	120–130°C / 248-266°F	+2°C / 36°F over alarm value

NOTE: Engine protection can be switched off.

Fuel pressure:

Standard value Volvo Penta	<2 bar (<29 psi)	Engine not switched off
----------------------------	------------------	-------------------------

Monitor, water in fuel: Alarm lamp lights

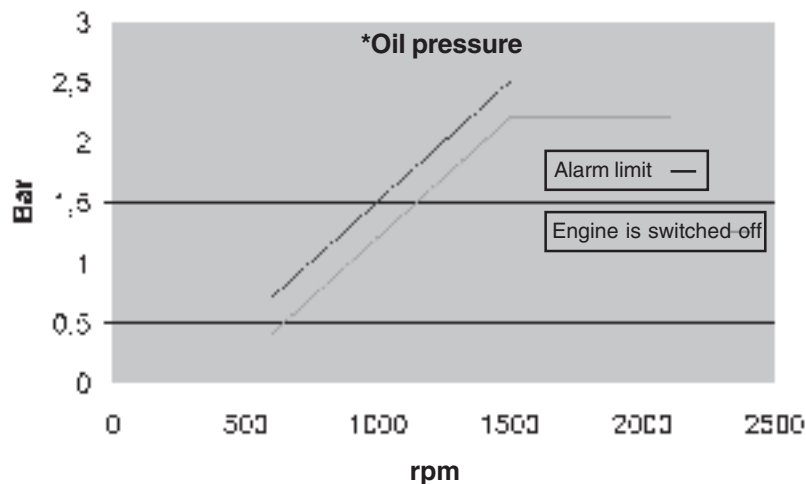

Limp-home values (emergency control values)

The control unit uses these bases value to be able to run the engine if a technical error arises in the system or its peripheral equipment, sensors, etc.

The following values (Limp-home values) are stored in the control unit:

Charge air temperature	+45°C / 113°F
Coolant temperature	-15°C / 5°F
Charge air pressure	See diagram below
Engine speed:	
TAD1240-42GE/VE	RPM frozen
TWD1240VE	Idle

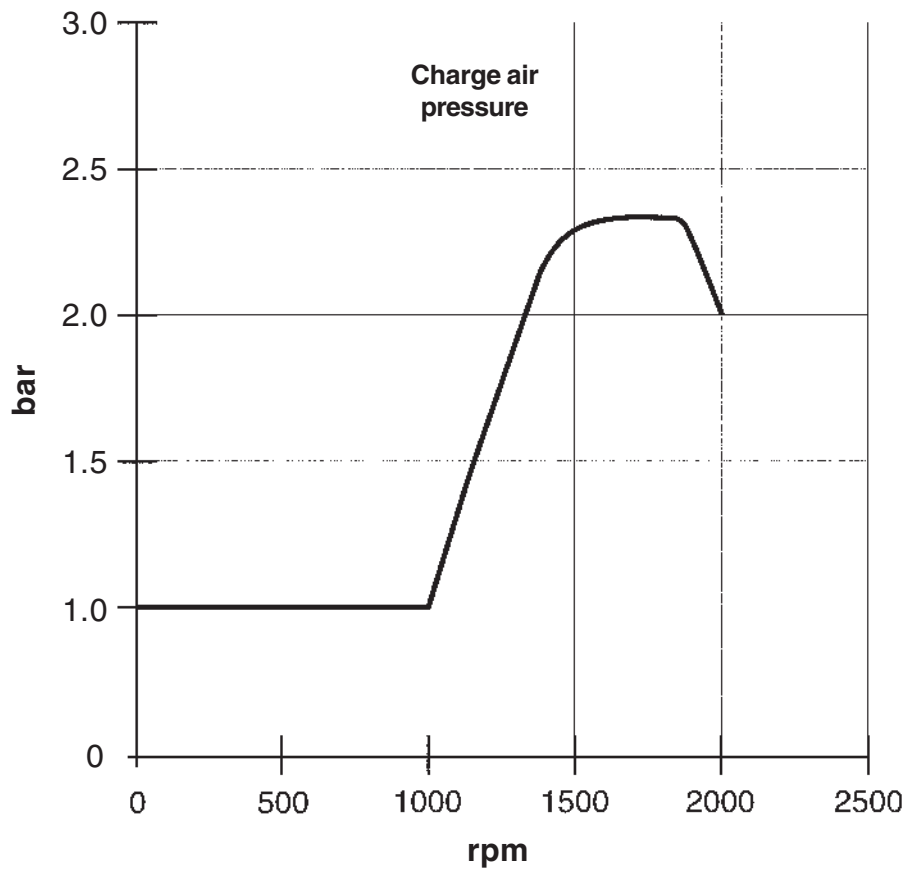

Repair instructions

When working with EDC III

Follow the instructions below so as not to damage the control unit of the EDC system:

- Never cut off the main current when the engine is running.
- Never disconnect battery cables when the engine is running.
- When quick charging the batteries, the main switch must be turned off or the battery cables must be disconnected.
During normal maintenance charging, the main switch does not need to be turned off.
- Only batteries should be used for jumping. Jumping devices may cause a surge and damage the control unit.
- Cut off power to the EDC III system before disconnecting the 2 x 36-pin cable glove from the control unit.
- If damage to the wiring harness is detected, the cable glove should be disconnected from the control unit.



IMPORTANT! The cable glove should be disconnected from the control unit when welding.

- When removing a connector from a sensor, be careful not to expose the contact pin to oil or any other fluid.
This could cause a contact problem or, if oil runs down to the pressure sensing membrane, the sensor could show an incorrect value.

Electronic Control unit (ECU), replacement

1. Cut off power to the engine.
2. Remove the fuel cooling coil and fuel line clamps from the control unit.
Bend aside the cooling coil.
3. Disconnect the cable glove from the control unit.
Press in the catch (1) and push the cable glove (2) upwards.
4. Remove the control unit.
5. Transfer the rubber cushions to the new control unit.
6. Fit the new control unit.
7. Connect the cable glove to the control unit.
When connecting the cable glove (2) to the control unit, make sure that the safety catch (1) is set.
8. Fit the cooling coil and fuel line clamps to the control unit.

NOTE: The retaining bolts of the fuel cooling coil are self-tapping as there are no threads in the control unit.

9. Start the engine and perform leakage and functionality checks.

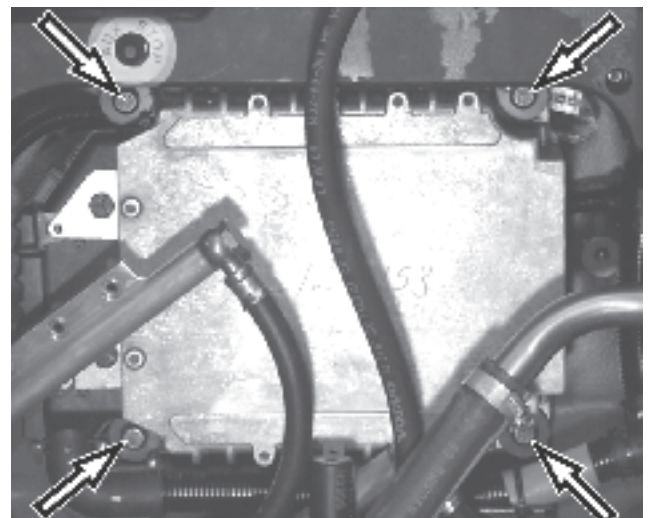
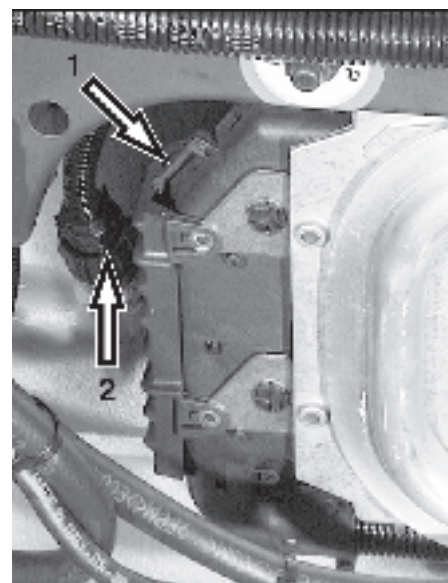
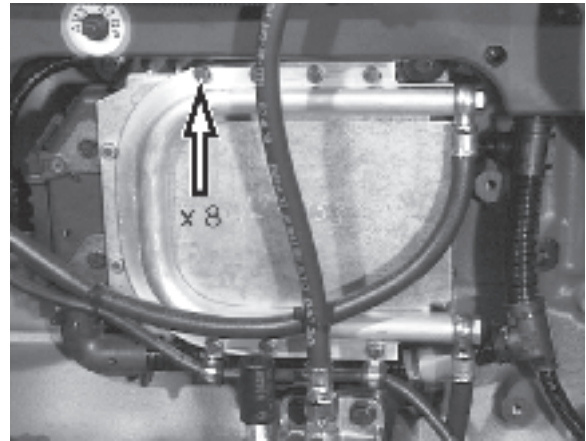

Start with booster batteries

⚠ WARNING! Be sure to have good ventilation. The batteries build oxyhydrogen gas, which is very flammable and explosive. A short-circuit, open flame or spark could cause an explosion.

⚠ WARNING! Never confuse the position of the cables on the battery. Confusing battery poles when jumpstarting with battery cables causes short-circuits and sparks, which can cause explosion and greatly damage electrical engine components.

1. Check that the voltage of the booster battery is the same as the engine's system voltage.
2. First connect the red (+) jumper cable to the **positive pole (+)** of the discharged batteries and then to the **positive pole (+) of the booster battery**.
3. Then connect the black (-) jumper cable to the **negative pole (-)** of the booster battery and a spot **a bit away from the negative pole (-)** of the discharged batteries, such as by the negative lead's connection to the starter motor.

⚠ WARNING! The black (-) jumper cable **must absolutely not** come in contact with the positive lead's connection to the starter motor.

4. Start the engine and run at high idle about 10 minutes to charge the batteries.

⚠ WARNING! Approaching or working on a running engine is a safety risk. Beware of rotating parts and hot surfaces. Do not touch the connections during the start attempt. Risk of sparks. Do not lean over any of the batteries.

5. Switch off the engine. Remove the jumper cables in **reverse order** from fitting. **One cable at a time!**



Functionality check

PC diagnostics program

- This program can read error codes that are stored in the engine control unit, check input and output signals, read current values from engine sensors and then store and print test results.
- The program enables service and workshop personnel to quickly localize and remedy errors in the EDC III system.
- A data link connector is used to connect to the engine control unit.
- User information is included in the program.
- Contact your Volvo Penta dealer to order software.
- The role of the diagnostic function is to detect and localize disturbances in the EDC III system, protect the engine and ensure that the machine remains in working order during serious disturbances.
- If a disturbance arises, the diagnostic indicator on the indicator panel begins blinking.
When the diagnosis button is pressed, an error code is given as guidance for any fault detection.

Fault detection

A number of symptoms and possible causes for engine problems are described in the table below. Always contact your Volvo Penta dealer if problems occur that you are not able to solve on your own.

⚠ WARNING! Read through the safety instructions for maintenance and service work in the chapter "Safety information" before starting to work.

Symptoms and possible causes

✱ Diagnosis button's indicator is blinking	See the chapter "Diagnostic function"
The engine cannot be stopped	2, 5
The starter motor does not rotate	1, 2, 3, 4, 5, 6, 7, 8, 25
The starter motor rotates slowly	1, 2
The starter motor rotates normally, but the engine does not start	9, 10, 11, 12, 13
The engine starts, but stops again	9, 10, 11, 12, 14
The engine does not reach the correct operating speed at full throttle	10, 11, 12, 13, 14, 22, 26, 27, 28, 29
The engine runs unevenly	11, 12, 13
High fuel consumption	13, 14, 16, 26
Black exhaust smoke	13, 14
Blue or white exhaust smoke	15, 16, 23
Low oil pressure	17
High coolant temperature	18, 19, 20, 21
Low coolant temperature	21
No or poor charging	2, 24

- | | | |
|---|---|---|
| 1. Discharged batteries | 11. Air in fuel system | 20. Faulty circulation pump |
| 2. Poor contact/interruption on electrical line | 12. Water/contaminates in the fuel | 21. Defective thermostat |
| 3. Main switch turned off | 13. Faulty unit injectors | 22. Clogged intercooler |
| 4. Fuse on wiring box blown | 14. Insufficient air supply to engine:
– clogged air filter
– air leak between turbocharger and engine's intake manifold
– fouled compressor in turbocharger
– faulty turbocharger
– poor engine compartment ventilation | 23. High oil level |
| 5. Faulty starter switch | 15. High coolant temperature | 24. Generator drive belt is slipping |
| 6. Faulty main relay | 16. Low coolant temperature | 25. Water in engine |
| 7. Faulty starter motor relay | 17. Low oil level | 26. Great counterpressure in exhaust system |
| 8. Faulty starter motor/solenoid | 18. Low coolant level | 27. Interruption, cable "Pot+" to pedal |
| 9. Fuel shortage:
– fuel cocks closed
– fuel tank empty/wrong tank connected | 19. Air in coolant system | 28. High oil temperature |
| 10. Clogged fuel fine filter/pre-filter (due to contaminants or paraffin deposits in the fuel at low temperature) | | 29. High charge-air temperature |

Diagnostic function

Diagnostic function

The diagnostic function checks that the EDC III system is functioning normally.

The diagnostic function performs the following tasks:

- Detects and localizes disturbances
- Notifies when disturbances are detected
- Provides guidance for fault detection
- Protects the engine and ensures that the machine remains in working order when serious disturbances are detected.

Notification of disturbance If the diagnostic function detects a disturbance in the EDC III system, the operator is notified by the diagnostic lamp (1), which begins to blink.

Guidance for fault detection If the diagnosis button (2) is depressed and then released the diagnostic lamp (1) blinks out an error code. The code is found in the error code list, with information on cause, response and corrective action.

The diagnostic function affects the engine in the following manner when:

- 1 The diagnostic function has detected a minor disturbance that will not damage the engine:
Response: The engine is not affected.
2. The diagnostic function has detected a serious disturbance that will not immediately damage the engine:
Response: TAD1240–42GE/VE: Engine is switched off.
TWD1240VE: Engine is switched off or engine torque is lowered until the value is normalized.
3. The diagnostic function has detected a serious disturbance that makes it impossible to control engine operation:
Response: TAD1240–42GE/VE: RPM maintained.
TWD1240VE: The engine goes to idle. Idle or freezing of RPM can be set using the Volvo Penta Parameter Tool.

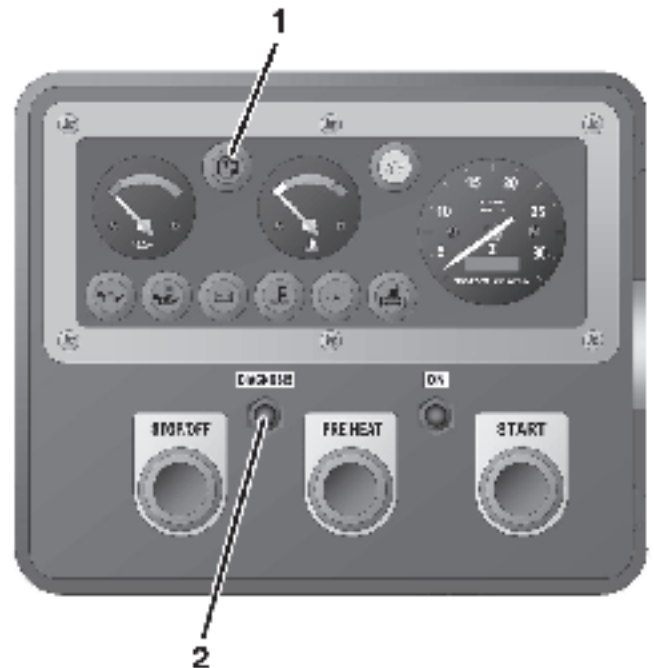

If the diagnosis button's indicator blinks

1. Reduce RPM to idle.
2. Press the diagnosis button (2) to acknowledge the message.
3. Release the diagnosis button and note the error code that blinks out. (1) See "Reading out error codes".
4. Look up the error code in the error code list and follow the recommended course of action.

NOTE: If the warning lamps and other instruments show normal function and the control is working normally, the operator can choose to continue operating and remedy the disturbance later. If the engine is switched off, certain error codes could disappear.

Reading out error codes

If the diagnosis button **2** is depressed and then released, an error code blinks out (**1**).

The error code consists of two groups of blinks separated by a two-second pause. The error code is read by counting the number of blinks in each group.

Example: ✨ ✨ pause ✨ ✨ ✨ ✨ = Error code 2.4

The error code is stored and can be read as long as the disturbance remains. The error code list contains information on cause, response and corrective action.

Read out as follows:

1. Press in the diagnosis button (**2**)
2. Release the diagnosis button and note the error code that blinks out (**1**).
3. Repeat points 1–2. A new error code blinks out if more codes are stored. Repeat until the first error code reappears.

NOTE: When the first error code reappears all error codes have been read out.

Erasing error codes

The error code memory of the diagnostic function is reset when power to the engine is cut off.

NOTE: The power must be completely disconnected.

When the power is turned on, the diagnostic function checks to see if there are any disturbances in the EDC III system. If disturbances are present, new error codes are set.

This means that:

1. Error codes for disturbances that have been corrected or that have disappeared are erased automatically.
2. Error codes for disturbances that have not been corrected must be acknowledged and read out every time the power is turned on.

If the diagnosis button is pushed after the error has been corrected and saved error codes are erased the code 1.1 ("No errors") will blink out.

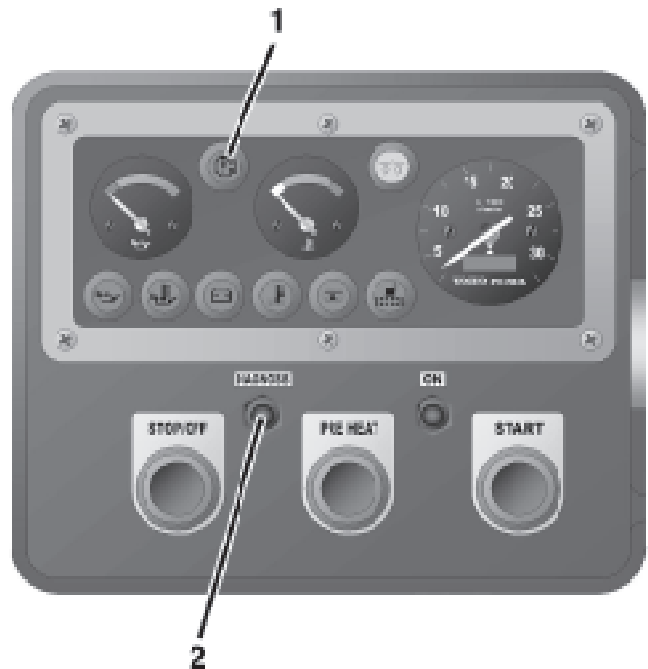

Error codes EDC III

⚠ WARNING! Read the safety instructions for maintenance and service work in the chapter "Safety information" before starting to work.

NOTE: The readout of the error codes below, such as **175 Code 2.1**, means that **175** is read using the diagnostic tool. **2.1** is the blink code that is shown on the instrument box's diagnostic lamp. See "Reading out error codes".

175 Code 2.1

Cause: Water in the fuel or low fuel pressure.

Response: Alarm lamp lights.

Corrective action:

- Check the fuel dehumidification filter (drain the fuel tank).
- Check if it is possible to increase the pressure using the hand pump.
- Check the fuel filter.
- Check the fuel pre-filter

191 Code 2.2

Cause: Low coolant level.

Response: Engine is switched off (if this protective feature has not been disabled by the parameter setting tool).

Alarm lamp lights.

Corrective action:

- Check the coolant level.
- Check the function of the coolant level monitor.

15 Code 2.4

Cause: Tachometer sensor, flywheel. No signal.

Response: The engine is extremely hard to start and runs unevenly if it does.

Corrective action:

- Check that the sensor connector is fitted correctly.
- Check that the wiring to the tachometer sensor is not damaged.
- Check that the tachometer sensor is correctly fitted in the flywheel housing.
- Check the function of the tachometer sensor.
- Check the contact pressure in sleeves 30 and 31 in the black cable glove of the engine control unit (ECU).

18 Code 2.4

Cause: RPM sensor, flywheel. Abnormal frequency.

Response: The engine is extremely hard to start and runs unevenly if it does.

Corrective action:

- Check that the tachometer sensor connector is fitted correctly.
- Check that the wiring to the tachometer sensor is not damaged.
- Check that the tachometer sensor is correctly fitted in the flywheel housing.
- Check the function of the tachometer sensor.

101 Code 2.4

Cause: Tachometer sensor, flywheel. Intermittent signal.

Response: The engine is extremely hard to start and runs unevenly if it does.

Corrective action:

- Check that the tachometer sensor connector is fitted correctly.
- Check that the wiring to the tachometer sensor is not damaged.
- Check that the tachometer sensor is correctly fitted in the flywheel housing.
- Check the function of the tachometer sensor.
- Check the contact pressure in sleeves 30 and 31 in the black cable glove of the engine control unit (ECU).

102 Code 2.5

Cause: RPM sensor, camshaft. No signal.

Response: The engine takes longer than normal to start. The engine runs normally once underway.

Corrective action:

- Check that the tachometer sensor connector is fitted correctly.
- Check that the wiring to the tachometer sensor is not damaged.
- Check that the tachometer sensor is correctly fitted in the upper timing cover.
- Check the function of the tachometer sensor.
- Check the contact pressure in sleeves 7 and 18 in the black cable glove of the engine control unit (ECU).

103 Code 2.5

Cause: RPM sensor, camshaft. Abnormal frequency.

Response: The engine takes longer than normal to start. The engine runs normally once underway.

Corrective action:

- Check that the tachometer sensor connector is fitted correctly.
- Check that the wiring to the tachometer sensor is not damaged.
- Check that the tachometer sensor is correctly fitted in the upper timing cover.
- Check the function of the tachometer sensor.

23 Code 2.7

Cause: RPM potentiometer connected to engine control unit (ECU).

Interrupted or shorted to positive (+).

Response: The engine goes to idle. If the pedal is released and then depressed again, the engine can "limp home" using the idle contact.

Corrective action:

- Check the the control's connector is fitted correctly.
- Check that the wiring to the sensor is not damaged.
- Check the function of the sensor.
- Check that the 23-pin connector is fitted correctly.
- Check pin C and sleeve C in the 23-pin connector.
- Check the contact pressure in sleeve 3 in the red cable glove of the engine control unit (ECU).

24 Code 2.7

Cause: RPM potentiometer connected to the engine control unit (ECU). Short to negative (-).

Response: The engine goes to idle. If the pedal is released and then depressed again, the engine can "limp home" using the idle contact.

Corrective action:

- Check that the potentiometer is connected correctly.
- Check that the wiring to the potentiometer is not damaged.
- Check the function of the potentiometer.

21 Code 2.8

Cause: RPM potentiometer connected to CIU. Short to negative (-).

Response: The engine goes to idle. If the pedal is released and then depressed again, the engine can "limp home" using the idle contact.

Corrective action:

- Check that the potentiometer is connected correctly.
- Check that the wiring to the potentiometer is not damaged.
- Check the function of the potentiometer.

22 Code 2.8

Cause: RPM potentiometer connected to CIU. Interrupted or shorted to positive (+).

Response: The engine goes to idle. If the pedal is released and then depressed again, the engine can "limp home" using the idle contact.

Corrective action:

- Check that the potentiometer is connected correctly.
- Check that the wiring to the potentiometer is not damaged.
- Check the function of the potentiometer.

181 Code 3.1

Cause 1: Oil pressure sensor. Short to positive (+).

Response: None.

Corrective action:

- Check that the wiring to the oil pressure sensor is not damaged.
- Check that the oil pressure sensor is connected correctly.

182 Code 3.1

Cause: Oil pressure sensor. Interrupted or shorted to negative (-).

Response: None.

Corrective action:

- Check that the wiring to the oil pressure sensor is not damaged.
- Check that the oil pressure sensor is connected correctly.
- Check the contact pressure in sleeve 14 in the black cable glove of the engine control unit (ECU).

25 Code 3.2

Cause: Charge air temperature sensor. Interrupted or shorted to positive (+).

Response: None.

Corrective action:

- Check that the connector of the charge air temperature sensor is fitted correctly.
- Check that the wiring to the charge air temperature sensor is not damaged.
- Check that the charge air temperature sensor is fitted correctly.
- Check the function of the charge air temperature sensor.
- Check the contact pressure in sleeve 2 in the black cable glove of the engine control unit (ECU).

26 Code 3.2

Cause: Charge air temperature sensor. Short to negative (-).

Response: None.

Corrective action:

- Check that the wiring to the charge air temperature sensor is not damaged.
- Check that the charge air temperature sensor is fitted correctly.
- Check the function of the charge air temperature sensor.

27 Code 3.3

Cause: Coolant temperature sensor. Interrupted or shorted to positive (+).

Response: Preheating is activated even if the engine is warm.

Corrective action:

- Check that the connector of the coolant temperature sensor is fitted correctly.
- Check that the wiring to the coolant temperature sensor is not damaged.
- Check that the coolant temperature sensor is fitted correctly.
- Check the function of the coolant temperature sensor.

28 Code 3.3

Cause 1: Coolant temperature sensor. Short to negative (-).

Response: Preheating is activated even if the engine is warm.

Corrective action:

- Check that the wiring to the coolant temperature sensor is not damaged.
- Check that the coolant temperature sensor is fitted correctly.
- Check the function of the coolant temperature sensor.

67 Code 3.4

Cause: Charge air pressure sensor. Short to positive (+).

Response: The engine smokes more than it usually does when accelerating/under loading.

Corrective action:

- Check that the wiring to the charge air pressure sensor is not damaged.
- Check the function of the charge air pressure sensor.

68 Code 3.4

Cause 1: Charge air pressure sensor. Interrupted or shorted to negative (-).

Response: The engine smokes more than it usually does when accelerating/under loading.

Corrective action:

- Check that the connector of the charge air pressure sensor is fitted correctly.
- Check that the wiring to the charge air pressure sensor is not damaged.
- Check that the charge air pressure sensor is fitted correctly.
- Check the function of the charge air pressure sensor.
- Check the contact pressure in sleeve 3 in the black cable glove of the engine control unit (ECU).

184 Code 3.7

Cause: Oil temperature sensor. Interrupted or shorted to positive (+).

Response: None.

Corrective action:

- Check that the wiring to the oil temperature sensor is not damaged.
- Check that the oil temperature sensor is correctly connected.
- Check the contact pressure in sleeve 1 in the black cable glove of the engine control unit (ECU).

185 Code 3.7

Cause: Oil temperature sensor. Short to negative (-).

Response: None.

Corrective action:

- Check that the wiring to the oil temperature sensor is not damaged.
- Check that the oil temperature sensor is correctly connected.

200 Code 4.1

Cause: Oil pressure alarm, circuit interrupted.

Response: Alarm lamp does not work. If the circuit is interrupted during start-up, diagnostics are deactivated.

Corrective action:

- Check the alarm lamp.
- Check that the wiring to the alarm lamp is not damaged.
- Check sleeve "L" in the 23-pin connector.
- Check the contact pressure in sleeve 35 in the red cable glove of the engine control unit (ECU).

201 Code 4.1

Cause: Oil pressure alarm. Short to negative (-).

Response: Alarm lamp lights constantly

Corrective action:

- Check that the wiring and connection to the alarm lamp are not damaged.

202 Code 4.1

Cause: Oil pressure alarm. Short to positive (+).

Response: Alarm lamp does not work. If the circuit is interrupted during start-up, diagnostics are deactivated.

Corrective action:

- Check that the wiring and connection to the alarm lamp are not damaged.

35 Code 4.2

Cause: Alarm for high coolant temp. Linked to Stand Alone interface. Short to negative (-).

Response: Alarm lamp lights constantly.

Corrective action:

- Check that the wiring to the alarm lamp is not damaged.
- Check that the alarm lamp is fitted correctly.

36 Code 4.2

Cause: Alarm for high coolant temp. Linked to Stand Alone interface. Short to positive (+).

Response: Alarm lamp does not work. If the circuit is interrupted during start-up, diagnostics are deactivated.

Corrective action:

- Check that the wiring to the alarm lamp is not damaged.
- Check that the alarm lamp is fitted correctly.

226 Code 4.2

Cause: Alarm for high coolant temp. Circuit interruption.

Response: Alarm lamp does not work. If the circuit is interrupted during start-up, diagnostics are deactivated.

Corrective action:

- Check the alarm lamp for high coolant temperature.
- Check that the wiring to the alarm lamp is not damaged.
- Check sleeve "N" in the 23-pin connector.
- Check the contact pressure in sleeve 33 in the black cable glove of the engine control unit (ECU).

220 Code 4.3

Cause: Lamp to indicate operation. Interruption

Response: Indicator lamp does not work. If the circuit is interrupted during start-up, diagnostics are deactivated.

Corrective action:

- Check the alarm lamp.
- Check that the wiring to the alarm lamp is not damaged.
- Check sleeve "N" in the 23-pin connector.
- Check the contact pressure in sleeve 33 in the black connector of the engine control unit (ECU).

221 Code 4.3

Cause: Lamp to indicate operation. Short to negative (-).

Response: The indicator lamp shines constantly.

Corrective action:

- Check that the wiring and connection to the alarm lamp are not damaged.

222 Code 4.3

Cause: Lamp to indicate operation. Short to positive (+).

Response: Indicator lamp does not work. If the circuit is interrupted during start-up, diagnostics are deactivated.

Corrective action:

- Check that the wiring and connection to the alarm lamp are not damaged.

223 Code 4.4

Cause: Overspeed alarm. Circuit interruption.

Response: Alarm lamp does not work. If the circuit is interrupted during start-up, diagnostics are deactivated.

Corrective action:

- Check the alarm lamp.
- Check that the wiring to the alarm lamp is not damaged.
- Check sleeve "O" in the 23-pin connector.
- Check the contact pressure in sleeve 36 in the black cable glove of the engine control unit (ECU).

224 Code 4.4

Cause: Overspeed alarm. Short to negative (-).

Response: Alarm lamp lights constantly.

Corrective action:

- Check that the wiring and connection to the alarm lamp are not damaged.

225 Code 4.4

Cause: Overspeed alarm. Short to positive (+).

Response: Alarm lamp does not work. If the circuit is interrupted during start-up, diagnostics are deactivated.

Corrective action:

- Check that the wiring and connection to the alarm lamp are not damaged.

203 Code 4.5

Cause: Low coolant alarm. Circuit interruption.

Response: Alarm lamp does not work. If the circuit is interrupted during start-up, diagnostics are deactivated.

Corrective action:

- Check the alarm lamp.
- Check that the wiring to the alarm lamp is not damaged.
- Check sleeve "N" in the 23-pin connector.
- Check the contact pressure in sleeve 33 in the black cable glove of the engine control unit (ECU).

204 Code 4.5

Cause: Low coolant alarm. Short to negative (-).

Response: Alarm lamp lights constantly.

Corrective action:

- Check that the wiring and connection to the alarm lamp are not damaged.

205 Code 4.5

Cause: Low coolant alarm. Short to positive (+).

Response: Alarm lamp does not work. If the circuit is interrupted during start-up, diagnostics are deactivated.

Corrective action:

- Check that the wiring and connection to the alarm lamp are not damaged.

41 Code 4.6

Cause: Start relay on starter motor. Short to positive (+).

Response: Engine will not start.

Corrective action:

- Check that the wiring to the relay is not damaged.
- Check the function of the relay.

42 Code 4.6

Cause: Start relay on starter motor. Short to negative (-).

Response: Engine will be started -> The starter motor engages, but no start request is made when the ignition is switched on.

Engine running -> The starter motor engages, but no start request is made.

Engine being started -> The starter motor does not disengage once the engine is started.

Corrective action:

- Check that the wiring to the relay is not damaged.
- Check the function of the relay.

107 Code 4.6

Cause: Starter motor relay. Circuit interruption.

Response: Engine will not start.

Corrective action:

- Check that the cable to the starter motor (yellow/black) is correctly connected.
- Check that the cable to the starter motor (yellow/black) is not damaged.
- Check that the relay on the starter motor is whole.
- Check the contact pressure in sleeve 31 in the red cable glove of the engine control unit (ECU).

108 Code 4.7

Cause: Start input, engine control unit (ECU). Short to negative (-).

Response: Engine will not start.

Corrective action:

- Check that the wiring to the ignition key/start button is not damaged.
- Check the contact pressure in sleeve "E" in the 23-pin connector.
- Check the contact pressure in sleeve 17 in the connector on the engine.

109 Code 4.8

Cause: Stop input engine control unit (ECU). Short to negative (-).

Response: The engine can only be stopped using the emergency stop on the engine.

Corrective action:

- Check that the wiring to the ignition key/start button is not damaged.
- Check the contact pressure in sleeve "H" in the 23-pin connector.
- Check the contact pressure in sleeve 6 in the connector on the engine.

43 Code 5.1

Cause: Main relay. Short to positive (+).

Response: The instrument panel loses power when the key is twisted to start position. The engine will not start.

Corrective action:

- Check that the wiring to the relay is not damaged.
- Check the function of the relay.

208 Code 5.2

Cause: Start input on CIU. Short to negative (-).

Response: The engine cannot be started.

Corrective action:

- Check that the connections to the ignition key are not damaged.
- Check that the wiring to the ignition key is not damaged.

210 Code 5.2

Cause: Start input on CIU. Short to positive (+) or activated too long.

Response: The engine starts immediately when the ignition is turned on.

Corrective action:

- Check that the connections to the ignition key are not damaged.
- Check that the wiring to the ignition key is not damaged.

209 Code 5.3

Cause: Stop input on CIU. Short to negative (-).

Response: The engine can only be stopped using the emergency stop on the engine.

Corrective action:

- Check that the connections to the ignition key are not damaged.
- Check that the wiring to the ignition key is not damaged.

211 Code 5.3

Cause: Stop input on CIU. Short to positive (+) or activated too long.

Response: The engine stops. After 40 seconds an error code is shown. During this time, the engine cannot be started. When the error code is blinked out on the diagnostic lamp, the engine can be started but not stopped.

Corrective action:

- Check that the connections to the ignition key are not damaged.
- Check that the wiring to the ignition key is not damaged.

214 Code 5.3

Cause: Stop input on CIU. Interrupted or activated too long.

Response: The engine stops. After 40 seconds an error code is shown. During this time, the engine cannot be started. When the error code is blinked out on the diagnostic lamp, the engine can be started but not stopped.

Corrective action:

- Check that the connections to the ignition key are not damaged.
- Check that the wiring to the ignition key is not damaged.

74 Code 5.4

Cause: Preheating relay. Connection interruption

Response: Preheating cannot be activated.

Corrective action:

- Check that the wiring to the input on the relay is not damaged.
- Check the function of the relay.
- Check the contact pressure in sleeve 36 in the red cable glove of the engine control unit (ECU).

75 Code 5.4

Cause: Preheating relay. Short to negative (-).

Response: Preheating is constantly activated.

Corrective action:

- Check that the wiring to the input on the relay is not damaged.
- Check the function of the relay.

76 Code 5.4

Cause: Preheating relay. Short to positive (+).

Response: Preheating cannot be activated.

Corrective action:

- Check that the wiring to the input on the relay is not damaged.
- Check the function of the relay.

183 Code 5.8

Cause: Oil temperature is too high.

Response: Limited engine output (if this protective feature has not been disabled by the parameter setting tool). Alarm lamp lights.

Corrective action:

- Check the oil level.
- Check the oil temperature.
- Check the oil system thermostat.
- Check the function of the oil temperature sensor.

31 Code 6.1

Cause: High coolant temperature.

Response: TAD1240–42GE: Limited engine output (if this protective feature has not been disabled by the parameter setting tool). Alarm lamp lights.

TWD1240VE: Engine is switched off (if this protective feature has not been disabled by the parameter setting tool). Alarm indicator lights.

Corrective action:

- Check the coolant level.
- Check the intercooler (cleanness).
- Check to see if there is air in the coolant system.
- Check the pressure cap on the expansion tank.
- Check the function of the coolant temperature sensor.
- Check the function of the thermostat.

60 Code 6.2

Cause: Intake air temperature is too high.

Response: Engine output is limited to 50% (if this protective feature has not been disabled by the parameter setting tool).

Corrective action:

- Check the coolant level.
- Check the intercooler (cleanness).
- Check the function of the charge air temperature sensor.
- Check the function of the thermostat.

213 Code 6.4

Cause: Datalink (CAN) error, CIU.

Response: Instruments and alarm lamps stop working.

Corrective action:

- Check that the 8-pin connector is not damaged.
- Check that the wiring between the CIU and the engine control unit (ECU) is not damaged.
- Check that sleeves 11 and 12 in the CIU connector are not damaged.
- Check the contact pressure in sleeves 1 and 2 in the red cable glove of the engine control unit (ECU).

38 Code 6.5

Cause: Datalink (CAN) error, engine control module (EMS).

Response: Engine not running: the engine cannot be started.

Engine running: engine goes to idle and can only be stopped using the emergency stop.

Corrective action:

- Check that the 8-pin connector is not damaged.
- Check that the wiring between the CIU and the engine control unit (ECU) is not damaged.
- Check that sleeves 11 and 12 in the CIU connector are not damaged.
- Check the contact pressure in sleeves 1 and 2 in the red cable glove of the engine control unit (ECU).

105 Code 6.5

Cause: Datalink error (CAN).

Response: Engine not running -> The engine cannot be started. Engine running -> Engine goes to idle and can only be stopped with the emergency stop.

Corrective action:

- Check that the 8-pin connector is not damaged.
- Check that the wiring between the CIU and the engine control unit (ECU) is not damaged.
- Check that sleeves 11 and 12 in the CIU connector are not damaged.
- Check the contact pressure in sleeves 1 and 2 in the red cable glove of the engine control module (EMS).

106 Code 6.5

Cause: Datalink error (CAN).

Response: Engine not running -> The engine cannot be started. Engine running -> Engine goes to idle and can only be stopped with the emergency stop.

Corrective action:

- Check that the 8-pin connector is not damaged.
- Check that the 8-pin cable between the CIU and the engine control unit (ECU) is not damaged.
- Check that sleeves 11 and 12 in the CIU connector are not damaged.
- Check the contact pressure in sleeves 1 and 2 in the red cable glove of the engine control unit (ECU).

180 Code 6.6

Cause: Oil pressure is too low.

Response: Engine is switched off (if this protective feature has not been disabled by the parameter setting tool).

Alarm lamp lights.

Corrective action:

- Check the oil level.
- Check that the oil filter is not clogged.
- Check the system pressure valves and the safety valve in the oil system.
- Check the function of the oil pressure sensor.

110 Code 7.1

Cause: Unit injector cylinder #1. Electronic error.

Response: The engine runs on 5 cylinders, sounds uneven and has decreased performance.

Corrective action:

- Check that the wiring to the unit injectors is not damaged.
- Check that the connections to the unit injector are not damaged.

111 Code 7.1

Cause: Unit injector cylinder #1. Electronic error.

Response: The engine runs on 5 cylinders, sounds uneven and has decreased performance.

Corrective action:

- Check that the wiring to the unit injectors is not damaged.
- Check that the connections to the unit injector are not damaged.

112 Code 7.1

Cause: Unit injector cylinder #1. Electronic error.

Response: The engine runs on 5 cylinders, sounds uneven and has decreased performance.

Corrective action:

- Check that the wiring to the unit injectors is not damaged.
- Check that the connections to the unit injector are not damaged.

113 Code 7.1

Cause: Unit injector cylinder #1. Electronic error.

Response: The engine runs on 5 cylinders, sounds uneven and has decreased performance.

Corrective action:

- Check that the wiring to the unit injectors is not damaged.
- Check that the connections to the unit injector are not damaged.

114 Code 7.1

Cause: Error in compression or the unit injector on cylinder #1.

Response: Cylinder balance is adversely affected -> Uneven running at low RPM and low load.

Corrective action:

- Check the fuel feed pressure.
- Check the valve clearance.
- Check that the unit injector and connection cable are not damaged.
- Do a compression test and check cylinder #1.

115 Code 7.1

Cause: Unit injector cylinder #1. Electronic error.

Response: The engine runs on 5 cylinders, sounds uneven and has decreased performance.

Corrective action:

- Check the contact pressure in sleeve 11 in the black cable glove of the engine control unit (ECU).
- Check that the wiring to the unit injectors is not damaged.
- Check that the connections to the unit injector are not damaged.

120 Code 7.2

Cause: Unit injector cylinder #2. Electronic error.

Response: The engine runs on 5 cylinders, sounds uneven and has decreased performance.

Corrective action:

- Check that the wiring to the unit injectors is not damaged.
- Check that the connections to the unit injector are not damaged.

121 Code 7.2

Cause: Unit injector cylinder #2. Electronic error.

Response: The engine runs on 5 cylinders, sounds uneven and has decreased performance.

Corrective action:

- Check that the wiring to the unit injectors is not damaged.
- Check that the connections to the unit injector are not damaged.

122 Code 7.2

Cause: Unit injector cylinder #2. Electronic error.

Response: The engine runs on 5 cylinders, sounds uneven and has decreased performance.

Corrective action:

- Check that the wiring to the unit injectors is not damaged.
- Check that the connections to the unit injector are not damaged.

123 Code 7.2

Cause: Unit injector cylinder #2. Electronic error.

Response: The engine runs on 5 cylinders, sounds uneven and has decreased performance.

Corrective action:

- Check that the wiring to the unit injectors is not damaged.
- Check that the connections to the unit injector are not damaged.

124 Code 7.2

Cause: Error in compression or the unit injector on cylinder #2.

Response: Cylinder balance is adversely affected -> Uneven running at low RPM and low load.

Corrective action:

- Check the fuel feed pressure.
- Check the valve clearance.
- Check that the unit injector and connection cable are not damaged.
- Do a compression test and check cylinder #2.
- Check the fuel feed pressure.

125 Code 7.2

Cause: Unit injector cylinder #2. Electronic error.

Response: The engine runs on 5 cylinders, sounds uneven and has decreased performance.

Corrective action:

- Check the contact pressure in sleeve 22 in the black cable glove of the engine control unit (ECU).
- Check that the wiring to the unit injectors is not damaged.
- Check that the connections to the unit injector are not damaged.

130 Code 7.3

Cause: Unit injector cylinder #3. Electronic error.

Response: The engine runs on 5 cylinders, sounds uneven and has decreased performance.

Corrective action:

- Check that the wiring to the unit injectors is not damaged.
- Check that the connections to the unit injector are not damaged.

131 Code 7.3

Cause: Unit injector cylinder #3. Electronic error.

Response: The engine runs on 5 cylinders, sounds uneven and has decreased performance.

Corrective action:

- Check that the wiring to the unit injectors is not damaged.
- Check that the connections to the unit injector are not damaged.

132 Code 7.3

Cause: Unit injector cylinder #3. Electronic error.

Response: The engine runs on 5 cylinders, sounds uneven and has decreased performance.

Corrective action:

- Check that the wiring to the unit injectors is not damaged.
- Check that the connections to the unit injector are not damaged.

133 Code 7.3

Cause: Unit injector cylinder #3. Electronic error.

Response: The engine runs on 5 cylinders, sounds uneven and has decreased performance.

Corrective action:

- Check that the wiring to the unit injectors is not damaged.
- Check that the connections to the unit injector are not damaged.

134 Code 7.3

Cause: Error in compression or the unit injector on cylinder #3.

Response: Cylinder balance is adversely affected -> Uneven running at low RPM and low load.

Corrective action:

- Check the fuel feed pressure.
- Check the valve clearance.
- Check that the unit injector and connection cable are not damaged.
- Do a compression test and check cylinder #3.

135 Code 7.3

Cause: Unit injector cylinder #3. Electronic error.

Response: The engine runs on 5 cylinders, sounds uneven and has decreased performance.

Corrective action:

- Check the contact pressure in sleeve 23 in the black cable glove of the engine control unit (ECU).
- Check that the wiring to the unit injectors is not damaged.
- Check that the connections to the unit injector are not damaged.

140 Code 7.4

Cause: Unit injector cylinder #4. Electronic error.

Response: The engine runs on 5 cylinders, sounds uneven and has decreased performance.

Corrective action:

- Check that the wiring to the unit injectors is not damaged.
- Check that the connections to the unit injector are not damaged.

141 Code 7.4

Cause: Unit injector cylinder #4. Electronic error.

Response: The engine runs on 5 cylinders, sounds uneven and has decreased performance.

Corrective action:

- Check that the wiring to the unit injectors is not damaged.
- Check that the connections to the unit injector are not damaged.

142 Code 7.4

Cause: Unit injector cylinder #4. Electronic error.

Response: The engine runs on 5 cylinders, sounds uneven and has decreased performance.

Corrective action:

- Check that the wiring to the unit injectors is not damaged.
- Check that the connections to the unit injector are not damaged.

143 Code 7.4

Cause: Unit injector cylinder #4. Electronic error.

Response: The engine runs on 5 cylinders, sounds uneven and has decreased performance.

Corrective action:

- Check that the wiring to the unit injectors is not damaged.
- Check that the connections to the unit injector are not damaged.

144 Code 7.4

Cause: Error in compression or the unit injector on cylinder #4.

Response: Cylinder balance is adversely affected -> Uneven running at low RPM and low load.

Corrective action:

- Check the fuel feed pressure.
- Check the valve clearance.
- Check that the unit injector and connection cable are not damaged.
- Do a compression test and check cylinder #4.

145 Code 7.4

Cause: Unit injector cylinder #4. Electronic error.

Response: The engine runs on 5 cylinders, sounds uneven and has decreased performance.

Corrective action:

- Check the contact pressure in sleeve 34 in the black cable glove of the engine control unit (ECU).
- Check that the wiring to the unit injectors is not damaged.
- Check that the connections to the unit injector are not damaged.

150 Code 7.5

Cause: Unit injector cylinder #5. Electronic error.

Response: The engine runs on 5 cylinders, sounds uneven and has decreased performance.

Corrective action:

- Check that the wiring to the unit injectors is not damaged.
- Check that the connections to the unit injector are not damaged.

151 Code 7.5

Cause: Unit injector cylinder #5. Electronic error.

Response: The engine runs on 5 cylinders, sounds uneven and has decreased performance.

Corrective action:

- Check that the wiring to the unit injectors is not damaged.
- Check that the connections to the unit injector are not damaged.

152 Code 7.5

Cause: Unit injector cylinder #5. Electronic error.

Response: The engine runs on 5 cylinders, sounds uneven and has decreased performance.

Corrective action:

- Check that the wiring to the unit injectors is not damaged.
- Check that the connections to the unit injector are not damaged.

153 Code 7.5

Cause: Unit injector cylinder #5. Electronic error.

Response: The engine runs on 5 cylinders, sounds uneven and has decreased performance.

Corrective action:

- Check that the wiring to the unit injectors is not damaged.
- Check that the connections to the unit injector are not damaged.

154 Code 7.5

Cause: Error in compression or the unit injector on cylinder #5.

Response: The engine runs on 5 cylinders, sounds uneven and has decreased performance.

Corrective action:

- Check that the wiring to the unit injectors is not damaged.
- Check that the connections to the unit injector are not damaged.
- Do a compression test and check cylinder #5.

155 Code 7.5

Cause: Unit injector cylinder #5. Electronic error.

Response: The engine runs on 5 cylinders, sounds uneven and has decreased performance.

Corrective action:

- Check the contact pressure in sleeve 35 in the black cable glove of the engine control unit (ECU).
- Check that the wiring to the unit injectors is not damaged.
- Check that the connections to the unit injector are not damaged.

160 Code 7.6

Cause: Unit injector cylinder #6. Electronic error.

Response: The engine runs on 5 cylinders, sounds uneven and has decreased performance.

Corrective action:

- Check that the wiring to the unit injector is not damaged.
- Check that the connection to the unit injector is not damaged.

161 Code 7.6

Cause: Unit injector cylinder #6. Electronic error.

Response: The engine runs on 5 cylinders, sounds uneven and has decreased performance.

Corrective action:

- Check that the wiring to the unit injector is not damaged.
- Check that the connection to the unit injector is not damaged.

162 Code 7.6

Cause: Unit injector cylinder #6. Electronic error.

Response: The engine runs on 5 cylinders, sounds uneven and has decreased performance.

Corrective action:

- Check that the wiring to the unit injector is not damaged.
- Check that the connection to the unit injector is not damaged.

163 Code 7.6

Cause: Unit injector cylinder #6. Electronic error.

Response: The engine runs on 5 cylinders, sounds uneven and has decreased performance.

Corrective action:

- Check that the wiring to the unit injector is not damaged.
- Check that the connection to the unit injector is not damaged.

164 Code 7.6

Cause: Error in compression or the unit injector on cylinder #6.

Response: Cylinder balance is adversely affected -> Uneven running at low RPM and low load.

Corrective action:

- Check the fuel feed pressure.
- Check the valve clearance.
- Check the unit injector and the connection cable.
- Do a compression test and check cylinder #6.

165 Code 7.6

Cause: Unit injector cylinder #6. Electronic error.

Response: The engine runs on 5 cylinders, sounds uneven and has decreased performance.

Corrective action:

- Check the contact pressure in sleeve 35 in the black cable glove of the engine control unit (ECU).
- Check that the wiring to the unit injector is not damaged.
- Check that the connection to the unit injector is not damaged.

82 Code 9.8

Cause: EEPROM error, CIU.

Response: CIU returns to factory settings.

Corrective action:

- Replace the CIU unit.

212 Code 9.8

Cause: Flash memory error, CIU.

Response: The engine goes to idle.

Corrective action:

- Replace the CIU unit.

254 Code 9.8

Cause: Controller failure, CIU

Response: The engine cannot be started, if the engine is running -> Idle.

Corrective action:

- Replace the CIU unit.

255 Code 9.9

Cause: Memory error in the engine control module (EMS).

Response: The engine cannot be started (varies).

Corrective action:

- Replace the engine control module (EMS).

32 Code -

Cause: Diagnostic lamp (linked to the Stand Alone interface). Interruption.

Response: The diagnostic lamp does not light during a lamp test. No error codes can be read out.

Corrective action:

- Check that the lamp is not damaged.
- Check that the wiring to the lamp is not damaged.
- Check the contact pressure in sleeve "J" in the 23-pin connector.
- Check the contact pressure in sleeve 21 in the red cable glove of the engine control unit (ECU).

33 Code -

Cause: Diagnostic lamp (linked to the Stand Alone interface). Short to negative (-).

Response: The diagnostic lamp shines constantly.

Corrective action:

- Check that the wiring to the lamp is not damaged.
- Check that the lamp is correctly mounted.

34 Code -

Cause: The diagnostic lamp (linked to the Stand Alone interface). Short to positive (+).

Response: The diagnostic lamp does not light during a lamp test. No error codes can be read out.

Corrective action:

- Check that the wiring to the lamp is not damaged.
- Check that the lamp is correctly mounted.

57 Code -

Cause: The charge air pressure is too high.

Response: None.

Corrective action:

- Check the function of the turbocharger.
- Check the function of the charge air pressure sensor.
- Check the fuel quantity/unit injector.

58 Code -

Cause: The charge air pressure is too low.

Response: The engine has decreased performance.

Corrective action:

- Check the function of the air filter.
- Check the function of the turbocharger.
- Check the function of the charge air pressure sensor.
- Check the fuel feed pressure.

63 Code -

Cause: Voltage feed to sensor. Short to positive (+).

Response: Several error codes for sensor error.

Corrective action:

- Check the contact pressure in sleeve 5 in the black cable glove of the engine control unit (ECU).

64 Code -

Cause: Voltage feed to sensor. Short to negative (-).

Response: Several error codes for sensor error.

Corrective action:

- Check the contact pressure in sleeve 4 in the black cable glove of the engine control unit (ECU).

173 Code -

Cause: Datalink (J1708) error, engine control unit (ECU).

Response: Diagnostic lamp shows only CIU internal errors.

Corrective action:

- Check that the 8-pin connector is not damaged.
- Check that the 8-pin cable between the CIU and the engine control unit (ECU) is not damaged.
- Check that pin/sleeve 22 and 37 in the connector on the CIU are not damaged.
- Check the contact pressure in sleeves 25 and 26 in the red cable glove of the engine control unit (ECU).

176 Code -

Cause: Monitor for water in the fuel or low fuel pressure. Short to positive (+).

Response: None.

Corrective action:

- Check that the wiring is not damaged.

186 Code -

Cause: Memory error in the engine control module (EMS).

Response: Engine will not start.

Corrective action:

- Replace the engine control unit (ECU).

187 Code -

Cause: Memory error in the engine control module (EMS).

Response: Engine will not start.

Corrective action:

- Replace the engine control unit (ECU).

188 Code -

Cause: Programming plug (EOL). Short to positive (+).

Response: Engine will not start; engine control unit (ECU) is in programming mode.

Corrective action:

- Check that the EOL contact is not strapped.
- Check that the wiring to the EOL contact is not damaged.

189 Code -

Cause: Programming plug (EOL). Short to negative (-).

Response: None.

Corrective action:

- Check that the wiring to the EOL contact is not damaged.

192 Code -

Cause: Coolant level monitor. Short to positive (+).

Response: None.

Corrective action:

- Check that the wiring to the coolant level monitor is not damaged.
- Check that the coolant level monitor is fitted correctly.

231 Code -

Cause: Input for preheating request. Short to negative (-).

Response: Pre-heating can not be activated.

Corrective action:

- Check that the wiring and the connection to the preheating switch are not damaged.

233 Code -

Cause: Datalink error (J1708), CIU.

Response: Diagnostic codes from the engine cannot be read from the diagnostic lamp.

Corrective action:

- Check that the 8-pin connector is not damaged.
- Check that the wiring between the CIU and the engine control unit (ECU) is not damaged.
- Check pin/sleeve 22 and 37 in the connector on the CIU.
- Check the contact pressure in sleeves 25 and 26 in the red cable glove of the engine control unit (ECU).



IMPORTANT! If error numbers 115, 125 and 135 are active simultaneously, check the contact pressure in sleeve 12 in the black cable glove of the engine control unit (ECU).



IMPORTANT! If error numbers 145, 155 and 165 are active simultaneously, check the contact pressure in sleeve 24 in the black cable glove of the engine control unit (ECU).

Electronic fault detection

General

Check the following before starting electronic fault detection:

- Error codes
- Fuel level and filter
- Air filter
- Battery
- Wiring (visually)
- Main switch, fuses, connectors
- Connections to relays

Electronic fault detection can be performed on the following components:

- Charge air/charge pressure sensor.
- Coolant temperature sensor.
- Water monitor for fuel pre-filter.
- Camshaft and flywheel sensors.
- Oil pressure/temperature sensor.
- Coolant level sensor.
- Unit injector (PC diagnostics program)
- Starter motor.
- Relays.
- Generator.

Functionality check of lines and connectors

First check that the fuse is not loose.

Use multimeter

9510060-8 to take a reading from the wiring.

Connect adapter 9998505 between the engine's cable glove and the control unit (ECU).

Use the wiring diagram to check that you are taking a reading from the correct spot.

Use multimeter 9510060-8 to take the reading.

NOTE: Never take a reading by puncturing the insulation.

Check the reading value with that which is noted in the wiring diagram.

If the reading can not be determined from the wiring diagram, check the lines separately.

Tool 9998534 should always be used when taking a reading from a 4-pin connector of type DIN contact.

Contact problems

Defective contacts or occasional recurring errors could be difficult to detect and arise often from oxidation, vibrations or poorly connected lines.

Wear can also cause errors. Avoid disconnecting a connector unless absolutely necessary.

Other contact problems can arise, such as through damaged pins, sleeves or connectors.

Shake the line and pull on the connections while measuring to find where the line is damaged.

The resistance in the contacts, lines and connections should be 0 Ohm.

There is some resistance, however, due to oxidation on the connections.

If resistance is too great, there will be disturbances in the function. How large resistance can be without disturbances arising varies depending on the size of the load in the circuit.

Check the following:

- Look for oxidation, which can deteriorate the contact in the connections.
- Check that the cable shoes are not damaged, that they are correctly fitted in the connector and that the line is correctly connected to the cable shoe.
- Test that the sleeves provide good mechanical contact.
Use a loose pin to test.

 **Important!** The cable glove of the control unit (ECU) should only be checked using gauge 9998482.

- Carefully insert gauge 9998482 in the cable glove. Move the gauge back and forth a few times until you feel that the cable glove clamps around the gauge. If the cable glove does not clamp or clamps weakly, the cable shoe must be replaced. See "Splicing electrical cable for cable glove".
- Fill the sleeves that have been checked with low temperature grease (1161417-9).

 **Important!** DIN contacts to **pressure sensors** must not be filled with grease.

- Check that the lines are really clamped. Avoid clamping the lines too close to the contacts.

Fault detection on cables and connectors

Visually check the connections.**Check the following:**

- Look for oxidation, which can deteriorate the contact in the connections.
- Check that the cable shoes are not damaged, that they are correctly fitted in the connector and that the line is correctly connected to the cable shoe.
- Test that the sleeves provide good mechanical contact.
Use a loose pin to test.
- Shake the line if possible and pull on the connections while measuring to find where the damage is.

Interruption

Chafed or worn lines or loose connections could be possible causes of error.

Use the wiring diagram to check which wiring harnesses are used for the function. Begin with the most probable wiring harness in the circuit.

Check the following:

- Disconnect the relevant connectors from both ends of the wiring harness.
- Measure the resistance using multimeter 9510060-8 between the ends of the line. Desired value $R \sim 0 \Omega$.
- Shake the line if possible and pull on the connections while measuring to find where the damage is.
- If you cannot find the error, check the next wiring harness following the wiring diagram.

Contact resistance and oxidation

The resistance in the contacts, lines and connections should be 0Ω .

There is some resistance, however, due to oxidation on the connections.

If resistance is too great, there will be disturbances in the function. How large resistance can be without disturbances arising varies depending on the size of the load in the circuit.

Check the following:

- Look for oxidation, which can deteriorate the contact in the connections.
- Check that the cable shoes are not damaged, that they are correctly fitted in the connector and that the line is correctly connected to the cable shoe.
- Test that the sleeves provide good mechanical contact.
Use a loose pin to test.

 **Important!** DIN contacts to **pressure sensors** must not be filled with grease.

Splicing electrical cable for cable glove

Special tools: 951 2636, 9999324

Repair kit: 1078054

1. Disconnect the cable glove from the control module. See "Control module, replacement". Remove the cable glove in such a way that the cable to the pin that is to be replaced is accessible.
2. Remove the pin using tool 9992636 or a very small instrument screwdriver.

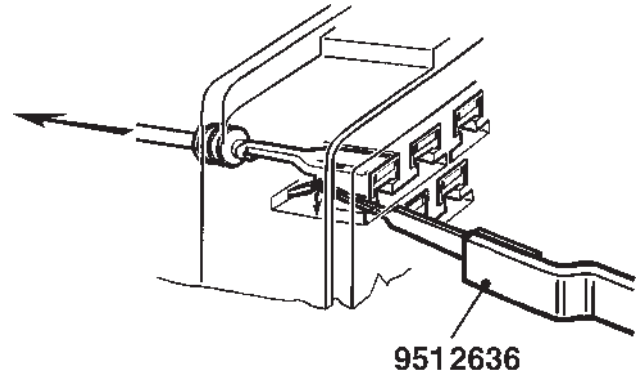

NOTE: Remove only one pin at a time.

3. Clip off the electrical cable at the pin that is to be replaced. Splice the new one using repair kit 1078054. Use cable shoe pliers 9999324.
4. Carefully warm the splice with a hot air gun so that the insulation shrinks and forms a seal.
5. If replacing several pins, put the first pin back into the correct spot in the cable glove before removing the next pin. Check that the pin's lock catch securely locks the pin in the cable glove.
6. Attach the electrical cables with insulation and cable tie in the cable glove in reverse order from removal.
7. Refit the cable glove in reverse order from removal.
8. Make sure that the cable glove and the connection to the control module are clean and dry.
9. Fit the cable glove to the control module. See "Control module, replacement".
10. Start the engine and check that no error codes arise.

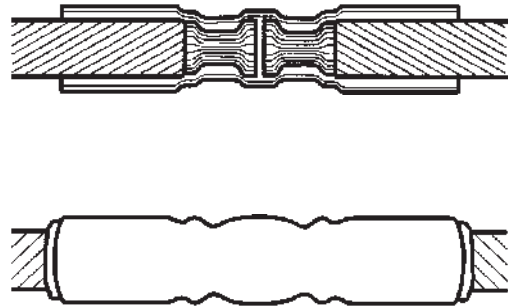
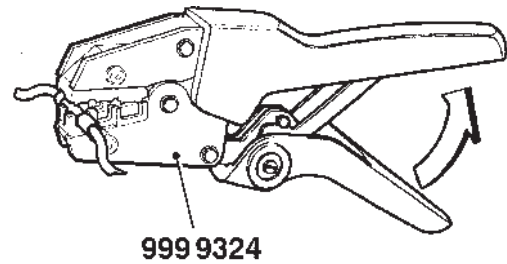

Checking the combined sensor for charge air pressure/temperature



Checking the coolant temperature sensor



Checking charge air pressure

1. Switch off the engine
2. Disconnect the connector from the charge air pressure sensor and connect 4-pin adapter 9998534 between the sensor connector and the engine wiring. Then connect multimeter 9510060-8 between measurement points 1-4.
3. Switch on the operating voltage.
4. Measure using a multimeter set to measure voltage. Check that the multimeter reads 5.0 volts.
5. Then connect the multimeter between measurement points 2-4. The voltage should be about 1.2 V at normal atmospheric pressure.

Checking charge air temperature

1. Disconnect the connector from the charge air pressure sensor.
2. Connect 4-pin adapter 9998534 between the sensor connector and multimeter 9510060-8.
3. Measure with the multimeter set to measure resistance between the measurement points of the adapter.
The multimeter should show the following values:

Measurement points	Desired values
3-4	R~6.2 kΩ (20°C / 68°F)
3-4	R~ 2.5 kΩ (40°C / 104°F)

NOTE: Even if resistance values follow those in the above table, it is no guarantee that the sensor is fault-free.

1. Disconnect the connector and remove the sensor from the engine.
2. Use multimeter 9510060-8 to measure between both contact pins of the sensor.
The multimeter should show the following values at:

0°C / 32°F	4930 Ω ± 440 Ω
20°C / 68°F	1870 Ω ± 140 Ω
40°C / 104°F	800 Ω ± 50 Ω
60°C / 140°F	370 Ω ± 20 Ω
80°C / 176°F	190 Ω ± 8 Ω
100°C / 212°F	104 Ω ± 4 Ω

NOTE: The sensor is extremely sensitive to changes in temperature. When measuring in the lower temperature interval 0–40°C / 32–104°F, holding the sensor in your hand is sufficient to make the value quickly go to the lower resistance value.

Checking water monitor, fuel pre-filter

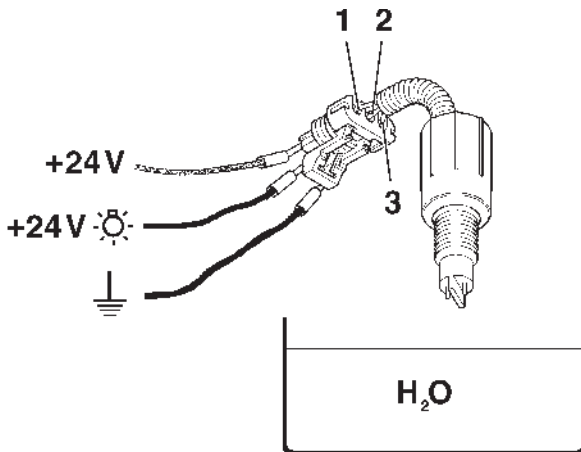

1. Red cable in connector.
2. Yellow cable in connector.
3. Black cable in connector.

1. Disconnect the connector and remove the water monitor from the fuel pre-filter.
2. Connect the red cable (1) to a 24V power source. Connect a light bulb (1W) between the yellow cable (2) in the connector and a +24V power source. Connect the black cable (3) in the connector to ground (-).
3. Submerge the sensor's contact pins in a bowl of water. The light bulb should light when the water is between the sensor's contact pins.
4. When the sensor is removed from the water, the light bulb should go out.

Checking the camshaft and flywheel sensors



The tachometer sensors for the camshaft and the flywheel are identical. For a visual check, first remove the sensors from the engine. Then disconnect the connector and check that the sensors are not damaged and that no debris has fastened on the sensors.

An induction test is performed as follows:

1. Set multimeter 9510060-8 to measure resistance. Use the multimeter to measure on the connector pins. Resistance should lie between 775–945 Ω.
2. Quickly pass a metal object close to the sensor. Check that the multimeter gives a reading. When replacing and fitting a sensor, make sure that any adjusting shims are refitted.
3. Check that the sensor is securely mounted and that the distance between sensor and wheel is correct.

Sensor	Distance
Flywheel	0.75–2.1 mm (0.03–0.83")
Camshaft	0.3–1.0 mm (0.012–0.039")

NOTE: For adjustment of the sense clearance, please see Workshop Manual (Group 21).

Checking the combined sensor for oil pressure/temperature



Checking the function of oil pressure

1. Switch off the engine
2. Disconnect the connector from the oil pressure sensor and connect 4-pin adapter 9998534 between the sensor connector and the engine wiring. Then connect multimeter 9510060-8 between measurement points 1-4.
3. Switch on the operating voltage.
4. Measure using a multimeter set to measure voltage. Check that the multimeter reads 5.0 volts.
5. Then connect the multimeter between measurement points 2-4. The voltage should be about 0.5 V.

Checking the function of oil temperature

1. Disconnect the connector from the oil pressure sensor.
2. Connect 4-pin adapter 9998534 between the sensor connector and multimeter 9510060-8.
3. Measure with the multimeter set to measure resistance between the measurement points of the adapter.
The multimeter should show the following values:

Measurement points	Desired values
3-4	R~1.9 k Ω (20°C / 68°F)
3-4	R~ 0.1 k Ω (100°C / 212°F)

NOTE: Even if resistance values follow those in the above table, it is no guarantee that the sensor is fault-free.

Checking the coolant level sensor

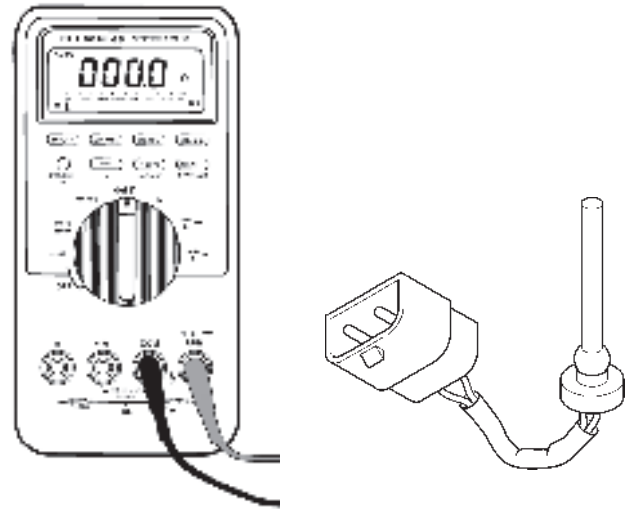

1. Empty the coolant from the expansion tank.
- Warning!** NEVER open the expansion tank's pressure cap when the engine is warm. Hot coolant could spray out, causing burns.
2. Disconnect the connector from the coolant sensor.
 3. Check that the contact is activated and sends a signal when the expansion tank is empty.
 4. Then fill the expansion tank with coolant and check that resistance remains the same.

Fault detection on unit injectors

Error symptoms

The engine runs unevenly or has decreased performance.

Error causes

The above error symptoms can have several causes:

- False sensor signals
- Worn piston rings
- Clogged air filter
- Poor quality fuel
- Water in fuel
- Air in fuel
- High exhaust counterpressure
- Clogged fuel system
- Low fuel pressure
- Incorrect valve clearance
- Defective unit injector
- Incipient shearing (breakdown)

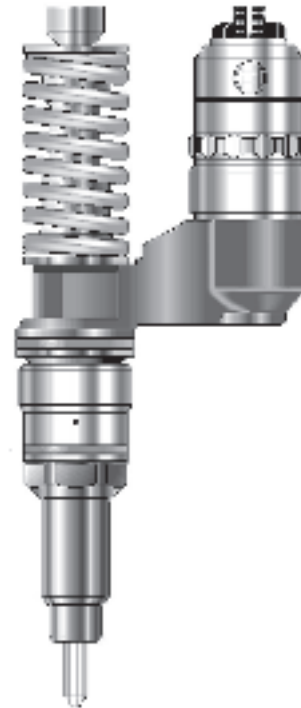

Determine or rule out error causes using the PC diagnostics program

NOTE: Read the instructions in the user manual for the "PC diagnostics program" before each test.

1. Perform a relative compression test on the cylinders.

Read the bar graph in the program. One or more bars will be at 100%. If any of the bars show a value lower than 80% relative compression, there is probably a compression error. Perform the test three times. If compression is within the limit values (80% - 100%), continue with the next point. There is a risk that all cylinders have poor compression.
2. Perform an injector test. Switch off one injector at a time. When a functional injector is switched off, the noise level of the engine will change. If that does not happen, there is probably an injector error.
3. Perform a relative acceleration test. Bear in mind that high engine speed gives inaccurate measurement results. Lower the engine speed when measuring. The test will calculate the average value of the relative cylinder acceleration from all cylinders. If the results from one cylinder differs from the other, it is probably an injector error or a symptom of poor compression.

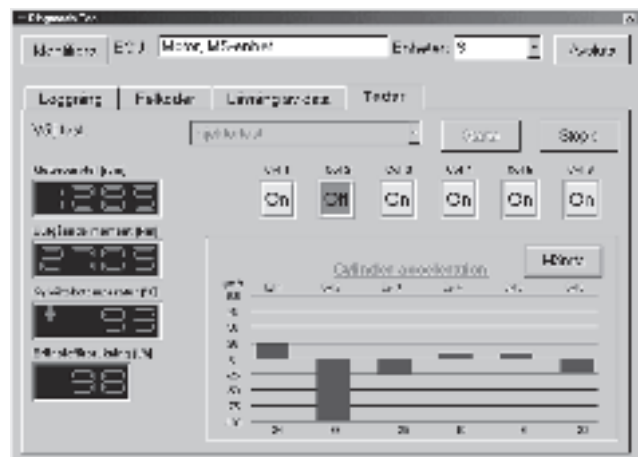
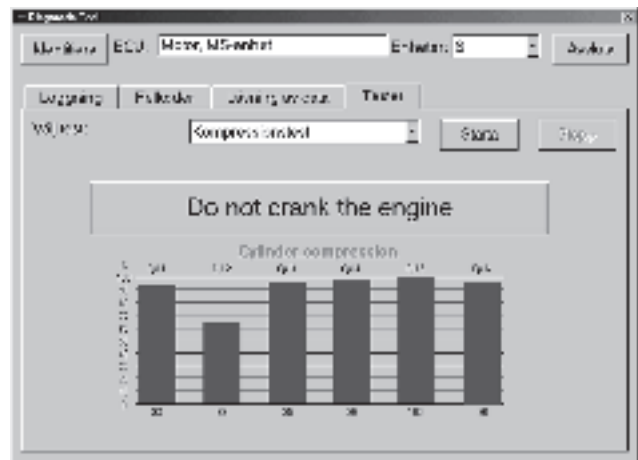

Fault detection on starter motor and lines

General

If the voltage level of the battery is under 24.7V as measured from the battery, the starter motor does not have enough power to rotate the engine at normal speed.

Checking voltage feed

1. Check that the voltage in the battery is at least 24.7V when unloaded by measuring between the battery poles with multimeter 9510060-8.
2. Turn on the main switch.
3. Check that the voltage between positions 30 and 31 on the starter motor are the same as the battery.

Check

1. That error code 4.6 is not set.
2. That a start request is sent (using the PC diagnostics program).
3. That the starter motor is activated (using the PC diagnostics program).

Carbon brushes

Specifications for carbon brushes in the starter motor are described below.

Carbon brush appearance

New = 23 mm (0.91")

Replace at 13 mm (0.51")

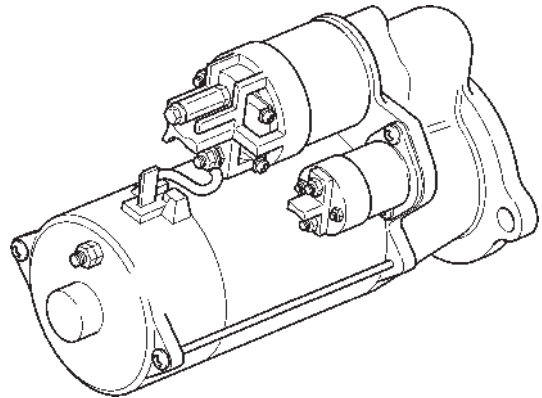

Functionality check of relays

Multimeter 9510060-8 is used for fault detection. Two different symbols are used to represent the line connection. Symbol **1** indicates an interruption or extremely high resistance (~). The multimeter does not emit an alarm.

Symbol **2** indicates a contact or extremely low resistance. The multimeter emits an alarm.

Check the function of the relays as follows:

NOTE: Disconnect the main relay from the engine before beginning fault detection.

1. Use the multimeter set to measure high frequencies. Measure between pins 87a and 30 of the relay. The multimeter should then emit an alarm sound.
2. Use the multimeter set to measure high frequencies. Measure between pins 87 and 30 of the relay. The multimeter should not emit an alarm.
3. Use the multimeter set to measure resistance. Measure between pins 85 and 86 of the relay. The multimeter should read 240–270 Ω.
4. Connect 24V between pins 85 and 86. Use the multimeter set to measure high frequencies. Measure between pins 87 and 30 of the relay. The multimeter should then emit an alarm sound.
5. Connect 24V between pins 85 and 86. Use the multimeter set to measure high frequencies. Measure between pins 87a and 30 of the relay. The multimeter should not emit an alarm.
6. Replace the relay if test results do not match those listed above.

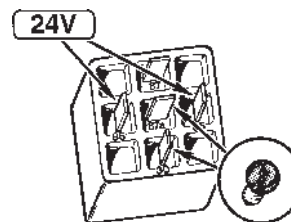
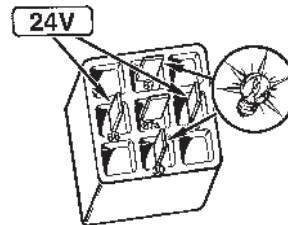
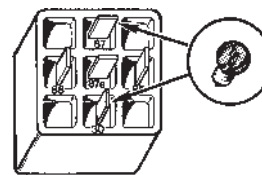
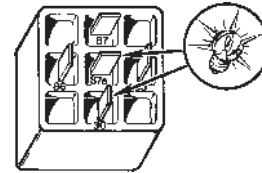
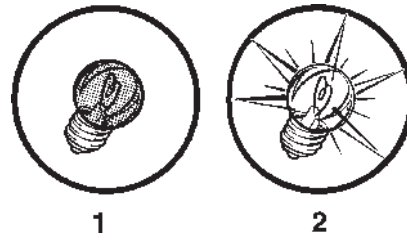

Fault detection on the generator

First remove the generator so that measurement points are accessible.

1. Pry loose the plastic cover of the generator with a screwdriver.
2. Remove the regulator's four screws.
3. Remove the bracket's two screws and remove the bracket and the regulator.



Carbon brushes

The length of carbon brushes is measured between the contact surface and the brush holder. If the size of the projecting portion is less than 0,2" or if the brushes are damaged, they must be replaced.

NOTE: When soldering, make sure that the solder does not penetrate too far in the line to the brushes. The line would then become stiff, hindering flexibility.

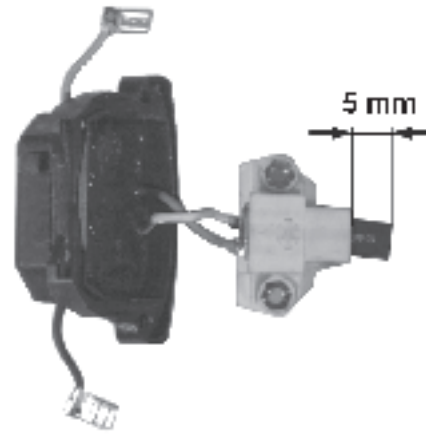

Regulator

Checking the regulator:

1. Measure with a multimeter set for diode measurement.
2. Connect the probes between the carbon brushes.
3. Switch the probes.
4. Check that there is no short-circuit.

NOTE: If you suspect a regulator error, it is best to fit a new regulator on the generator and test run the charging system.



Checking positive output diodes

1. Set the multimeter for diode measurement.
2. Connect the negative test probe to B+ and the positive test probe to each of the three stator windings.
3. Take readings of the three stator windings.
4. Switch the test probes and take three more readings.
5. One time, the instrument should read 400–1200mV (conducting direction). The other time, it should read OL.
The diodes obstruct.

NOTE: The entire diode package is insulated from the body of the generator.

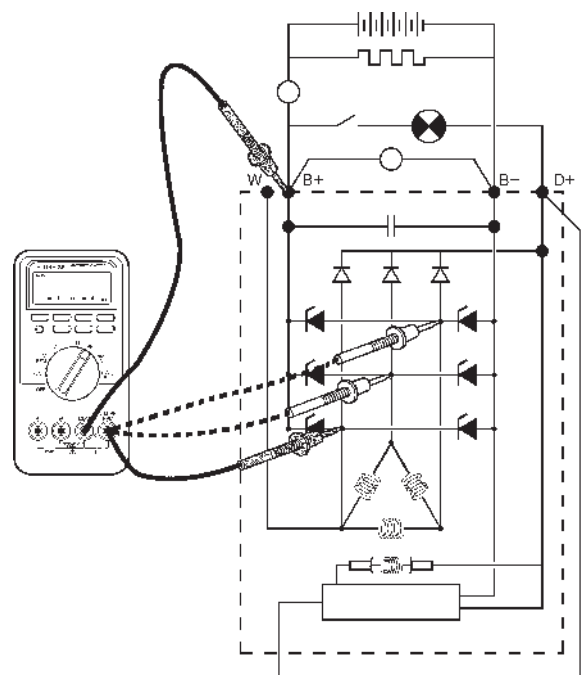
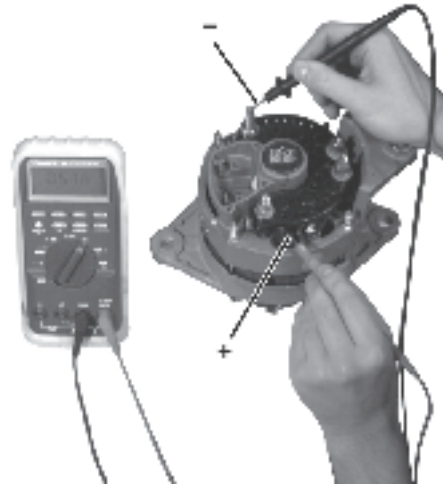

Checking negative output diodes

1. Set the multimeter for diode measurement.
2. Connect the negative test probe to B- and the positive test probe to each of the three stator windings.
3. Take readings of the three stator windings.
4. Switch the test probes and take three more readings.
5. One time, the instrument should read 400–1200mV (conducting direction). The other time, it should read OL.
The diodes obstruct.

NOTE: The entire diode package is insulated from the body of the generator.

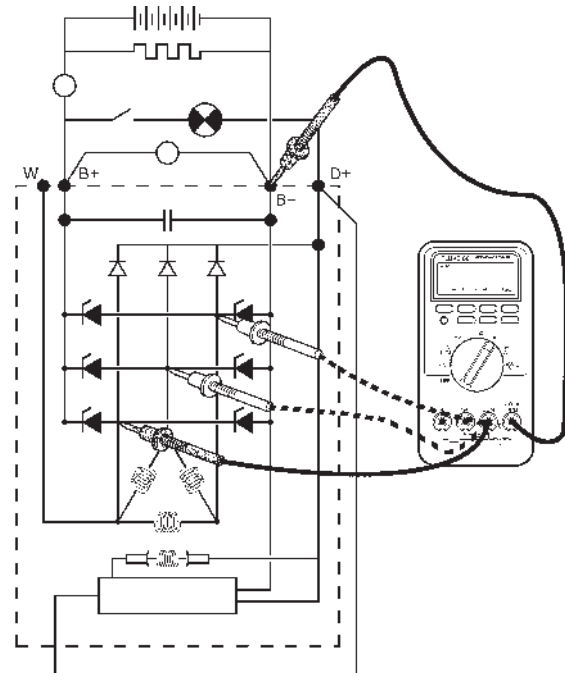
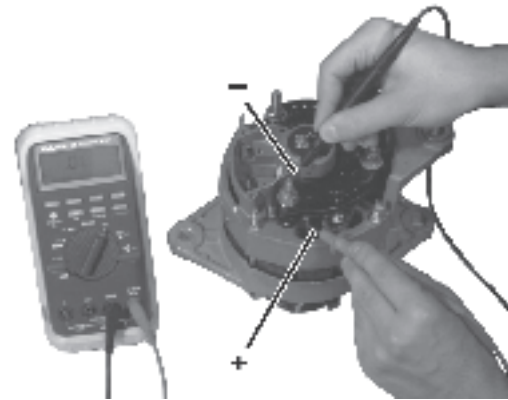
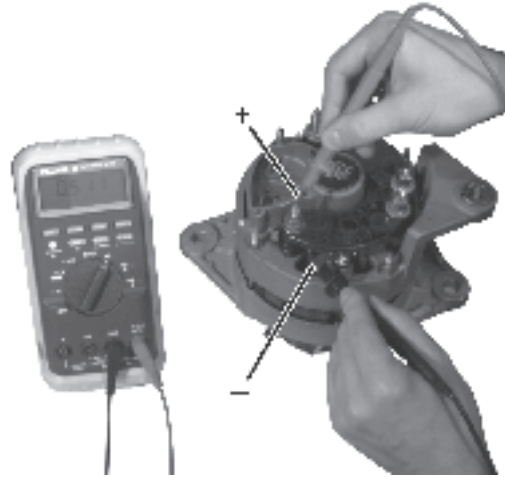

Checking excitation diodes

1. Set the multimeter for diode measurement.
2. Connect the negative test probe to D+ and the positive test probe to each of the three stator windings.
3. Take readings of the three stator windings.
4. Switch the test probes and take three more readings.
5. One time, the instrument should read 400–1200mV (conducting direction). The other time, it should read OL.

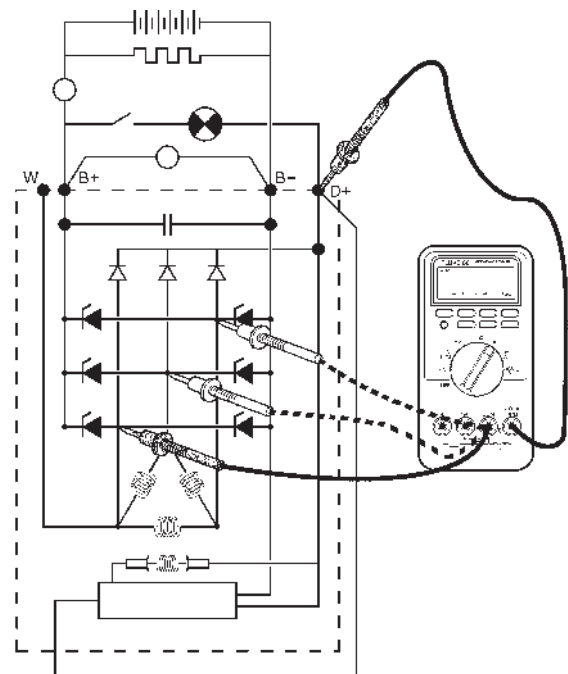
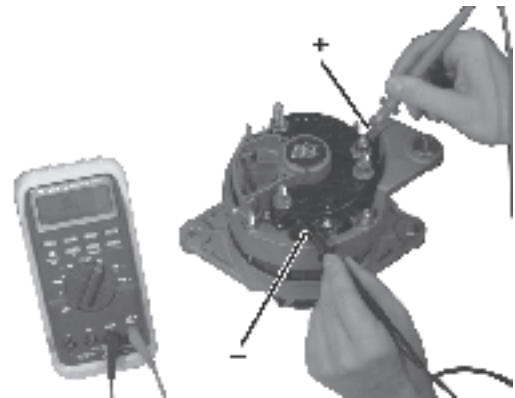
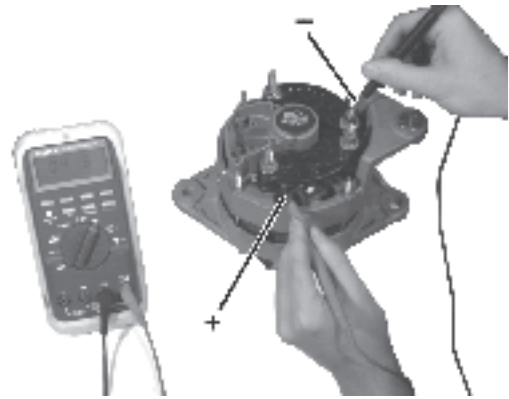

Checking stator windings

1. Set the multimeter for diode measurement.
2. Connect the test probes between the phase connections.
3. Take three readings.
4. The instrument should show the same value for all three readings.

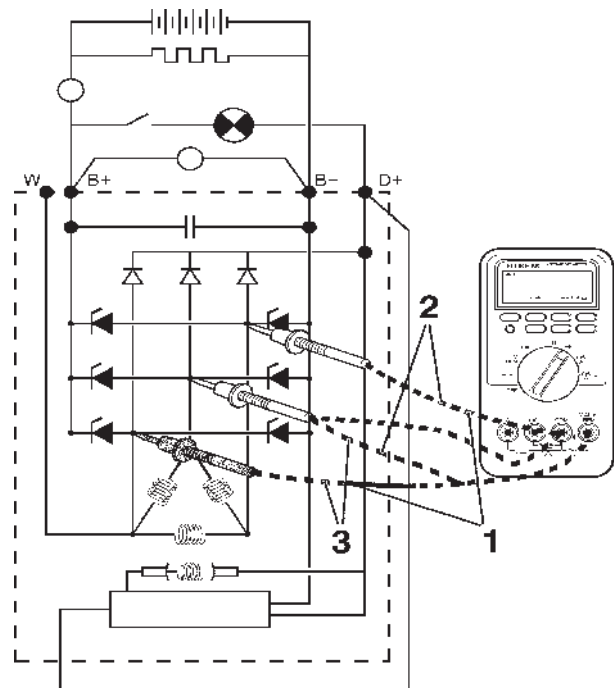
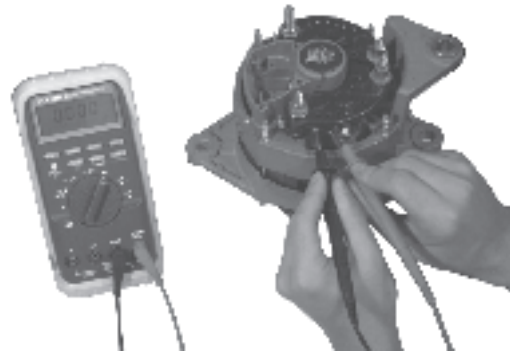

Overload test on stator

1. Set the multimeter for diode measurement.
2. Connect the test probes between the stator body and one of the three stator windings.
3. The instrument should read OL. If any other value is shown, the stator is short-circuited.



Checking the rotor

- 1 Set the multimeter for diode measurement.
- 2 Connect the test probes to the slip rings.
- 3 The instrument reading should be nonexistent or very weak.
- 4 At the same time, check that the slip rings are not burned or otherwise damaged.

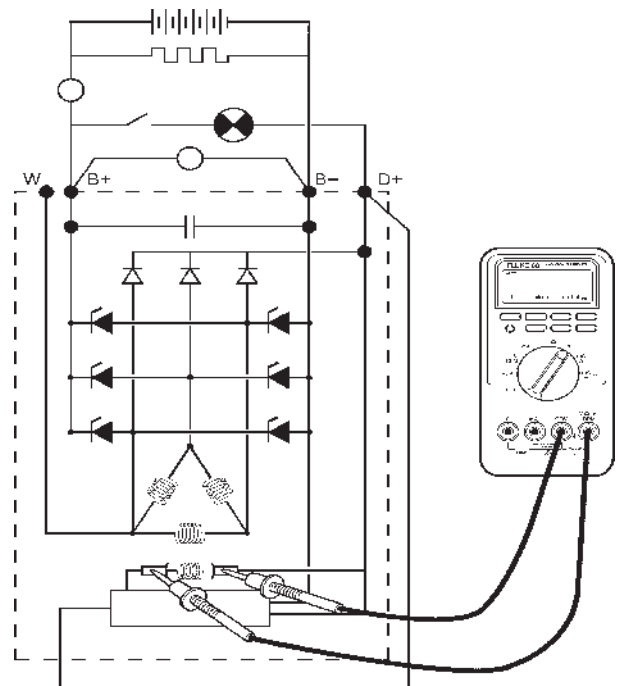

Overload test on rotor

- 1 Set the multimeter for diode measurement.
- 2 Connect the test probes between the stator body and one of the three stator windings.
- 3 The instrument should read OL.
If any other value is shown, the stator is short-circuited.



Electrical system

Important about the electrical system

 **Important!** Stop the engine and cut off the power with the main switch before working with the electrical system.

1. Main switch

Never open the circuit between the generator and the batteries when the engine is running. The main switch/switches must never be switched off before the engine has stopped. If the circuit is opened when the engine is running, the voltage regulator can be ruined and the generator can be badly damaged. For the same reason, charging circuits must not be switched when the engine is running. For simultaneous charging of two independent battery circuits, a Volvo Penta charge distributor can be mounted on the standard generator (accessory).

2. Batteries

Never mistake the positive and negative poles for each other when installing the batteries. This could cause serious damage to the electrical equipment. Compare with the wiring diagram. Battery poles should be well cleaned and cable shoes should always be secured and well greased. Avoid quick charging the batteries. If quick charging must be used, the ordinary battery cables must first be disconnected.

NOTE: Follow applicable safety regulations when charging the batteries.

When charging, the cell plugs should be loosened but remain in the cell hole. Ventilate well, especially if the batteries are being charged in a confined area.

Never cut off the charging current **before** disconnecting the charge clamps.

 **Warning!** The battery compartment must never be exposed to open flames or electric sparks. Never smoke near the batteries. When the batteries are being charged, they give off hydrogen which, when mixed with air, forms oxyhydrogen gas. This gas is highly flammable and very explosive.

Always wear protective goggles when charging and handling batteries.

The battery electrolyte contains highly corrosive sulfuric acid.

If it gets on your skin, wash the area with soap and plenty of water. If the electrolyte gets in your eyes, rinse them at once with plenty of cold water and seek medical attention immediately.

3. See "Start with booster batteries" on how to jump start using booster batteries.

4. Connecting extra equipment

All extra equipment must be connected to a separate junction box and fused.

Extra outlets directly from the instrument boards should be avoided. Extra outlets are permissible only up to a **max. total of 5A** (applies for all instrument boards together).

Electric welding

Remove the positive and negative cables from the batteries.

Then remove all connections to the generator.

Then remove the cable glove from the control module (EDC III). See the instructions in "Control module (EMS), replacement".

Always attach welding clamps to the part that is to be welded as close to the welding area as possible. The clamps must never be attached to the engine or in such a way that current can pass over any bearing.

 **Important!** After welding, the removed components, such as cable glove, generator cable and battery cables, must be refitted in the correct order.

Electrical system, overview

TWD1240VE Stand alone

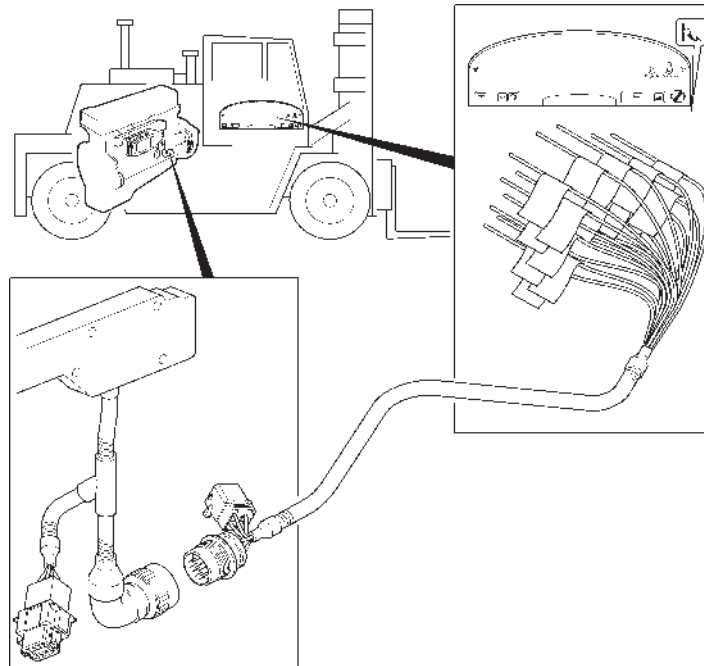

TWD1240VE with CIU, CAN based SAE J1939

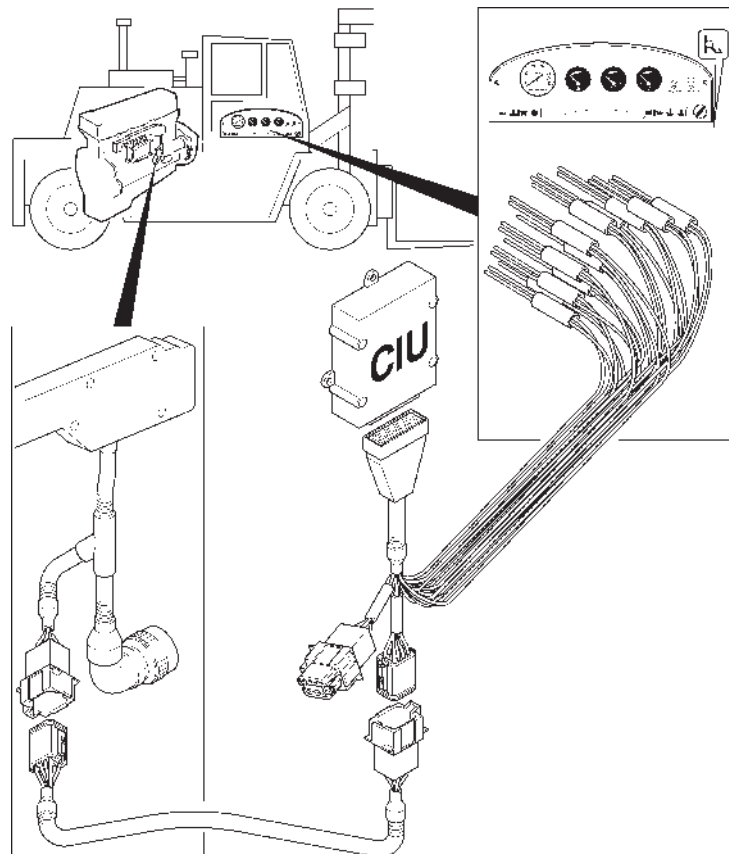

TWD1240VE Power pack

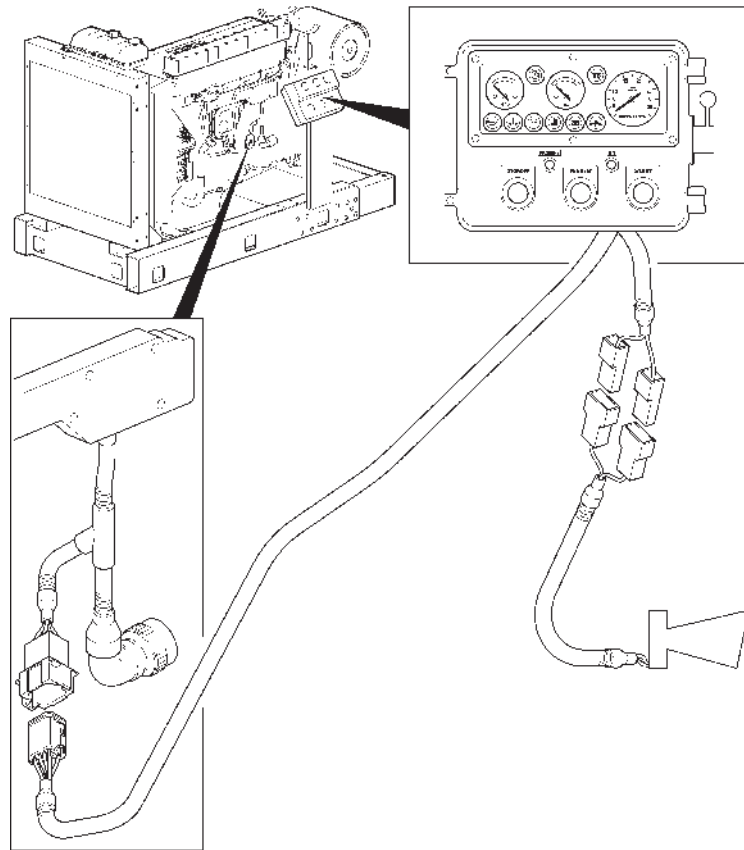

TAD1240-42GE with CIU, CAN based SAE J1939 TAD1241-42VE with CIU, CAN based SAE J1939

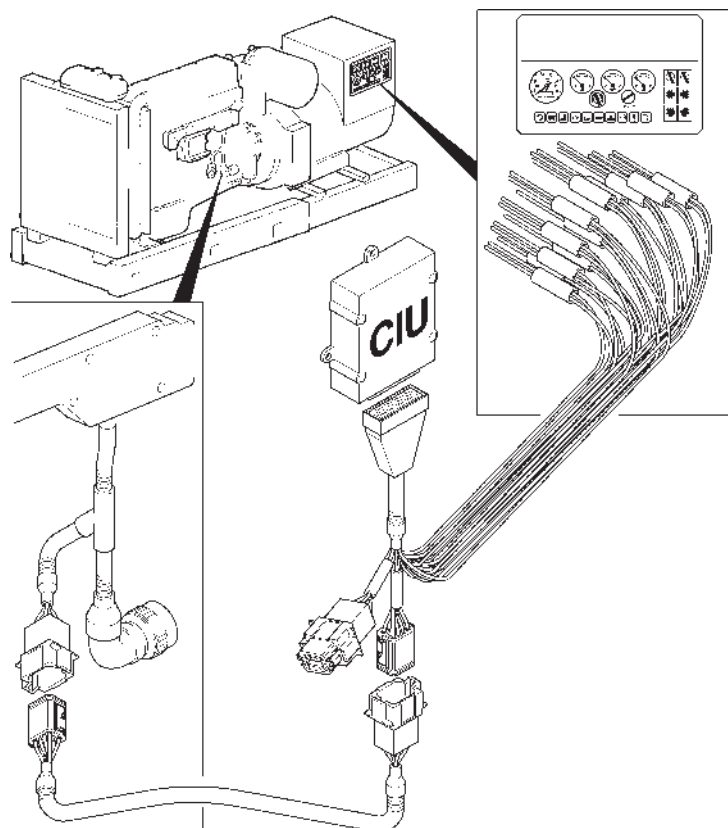

TAD1240-42GE Stand alone

TAD1241-42VE Stand alone

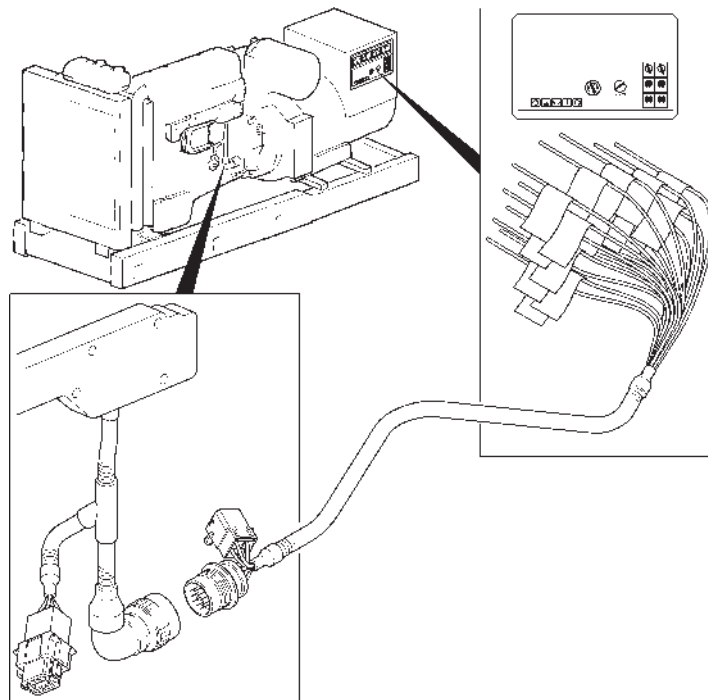

**TAD1240-42GE, TAD1241-42VE
(24 V system voltage, 2-pin)**

1. RPM potentiometer
2. 1500/1800 contact
3. Starter contact
4. Idle contact
5. Stop contact
6. Diagnostics
7. Low oil pressure alarm
8. High coolant temperature alarm
9. Indicator, engine running
10. Overspeed alarm
11. Voltage after key
12. Battery, negative
13. Battery, positive
14. Nyckelbrytare
15. J1587 (bus)
16. J1939 CAN (bus)
17. Battery, negative
18. Battery, positive
19. Voltage after key
20. Connector
21. Programming connector
22. Diode
23. Monitor, water in fuel
24. Relay socket
25. Main relay
26. Monitor, fuel pressure
27. Monitor, coolant level
28. Stop
29. Programming plug
30. Connector 2 (red)
31. Connector 1 (black)
32. Control unit, EDC III (ECU)
33. Unit injector
34. Coolant temperature sensor
35. Sensor, charge air temperature/pressure
36. Preheat function (NOT available for Genset application)
37. Camshaft (RPM) sensor
38. Flywheel (RPM) sensor
39. Generator
40. Starter motor
41. Sensor, oil temperature/pressure
42. Battery (24 V)

- Cable colors**
- BL = Blue
 - LBL = Lightblue
 - BN = Brown
 - LBN = Lightbrown
 - GN = Green
 - GR = Gray
 - OR = Orange
 - P = Pink
 - R = Red
 - SB = Black
 - VO = Violet
 - W = White
 - Y = Yellow

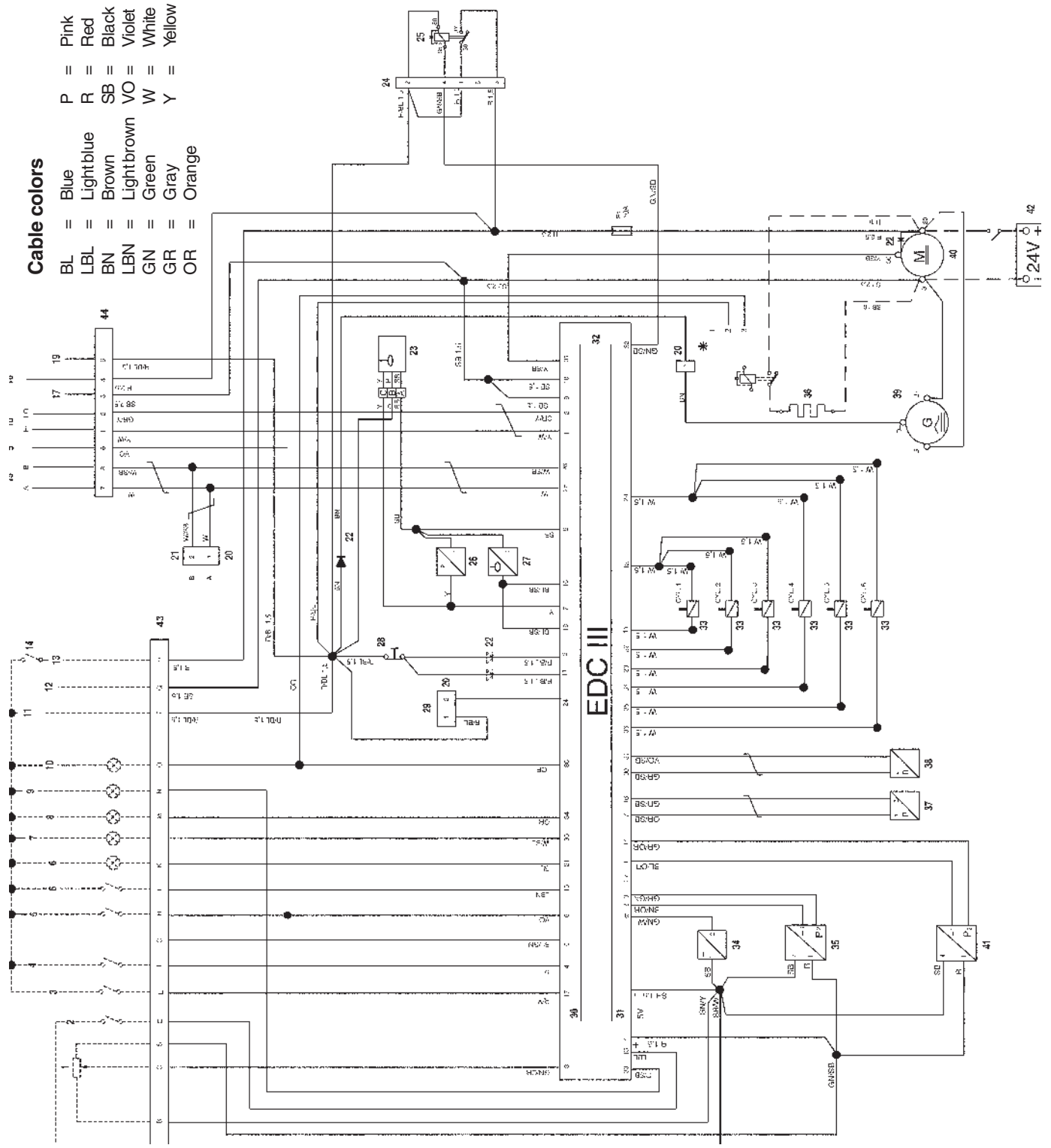

TWD1240VE (24 V system voltage, 2-pin)

1. RPM potentiometer
2. Droop contact
3. Starter contact
4. Idle contact
5. Preheating contact
6. Stop contact
7. Diagnostics
8. Low oil pressure alarm
9. High coolant temperature alarm
10. Low coolant level alarm
11. Preheating indicator
12. Voltage after key
13. Battery, negative
14. System to (key)
15. Battery, positive
16. J1587 (bus)
17. J1939 CAN (bus)
18. Battery, negative
19. Battery, positive
20. Voltage after key
21. Connector
22. Programming connector
23. Diode
24. Stop button
25. Monitor, water in fuel
26. Relay, socket
27. Relay
28. Programming plug
29. Monitor, fuel pressure
30. Monitor, coolant level
31. Connector 2 (red)
32. Connector 1 (black)
33. Control unit EDCIII (ECU)
34. Unit injectors (Cyl. 1-6)
35. Coolant temperature sensor
36. Sensor, Charge air temperature/pressure
37. Preheating
38. Relay, preheating
39. Camshaft (RPM) sensor
40. Flywheel (RPM) sensor
41. Generator
42. Starter motor
43. Sensor, oil temperature/pressure
44. Battery (24 V)

- Cable colors**
- BL = Blue
 - LBL = Lightblue
 - BN = Brown
 - LBN = Lightbrown
 - GN = Green
 - GR = Gray
 - OR = Orange
 - P = Pink
 - R = Red
 - SB = Black
 - VO = Violet
 - W = White
 - Y = Yellow

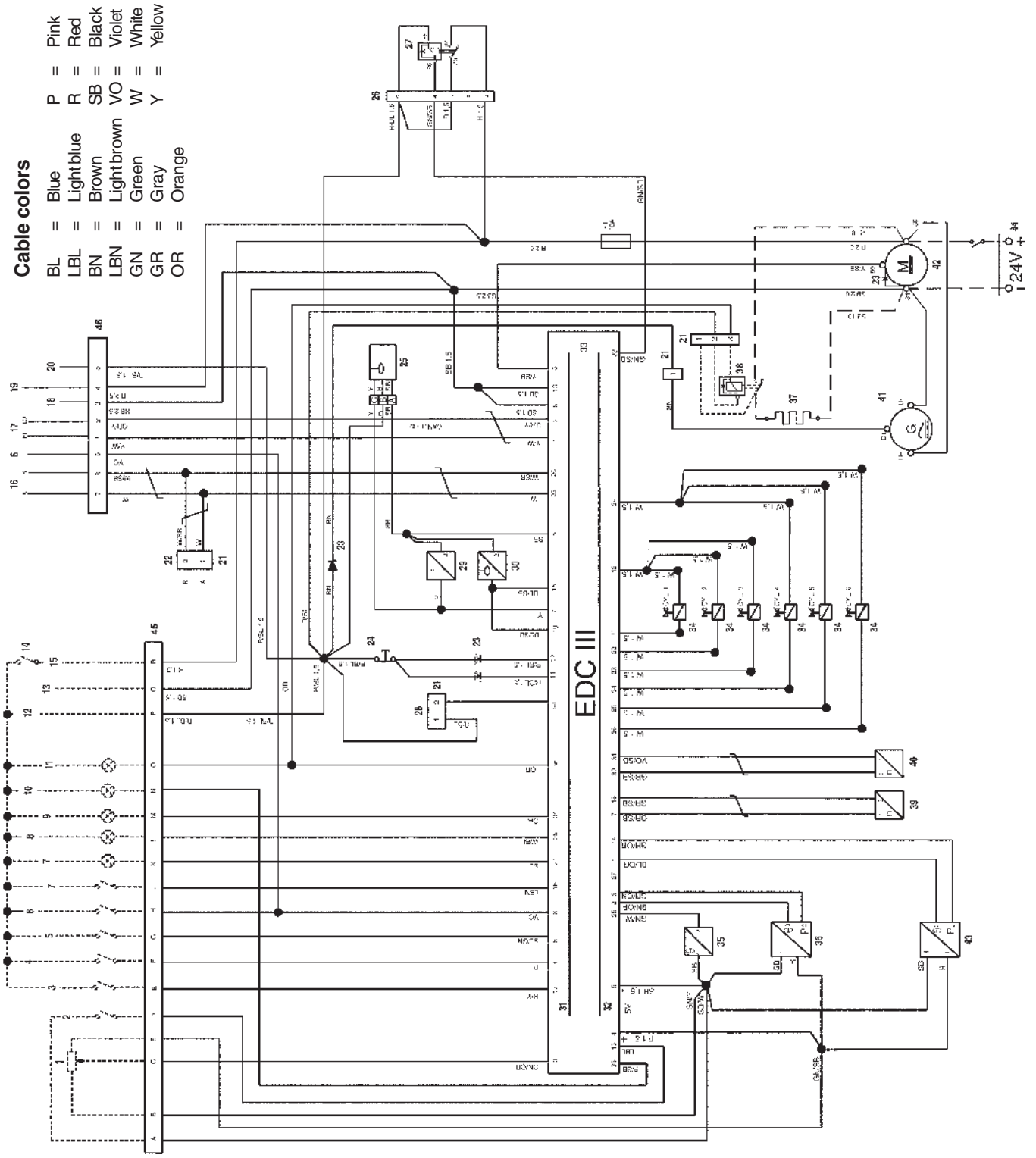

Cable colors

- BL = Blue
- LBL = Light blue
- BN = Brown
- LBN = Light brown
- GN = Green
- GR = Gray
- OR = Orange
- P = Pink
- R = Red
- SB = Black
- VO = Violet
- W = White
- Y = Yellow

Wiring diagram, Control Interface Unit (CIU)

1. Key breaker operating power (15+)
2. RPM potentiometer
3. Tachometer code 14
4. Oil pressure, instrument
5. Oil temperature, instrument
6. Coolant temperature, instrument
7. Instrument illumination
8. Idle contact, two-position (Genset)
9. 1500/1800 contact, two-position (Genset)
10. Starter contact, non-locking
11. Stop contact, non-locking
12. Diagnosis contact, non-locking
13. Alarm, low oil pressure
14. Alarm, high oil temperature
15. Alarm, high coolant temperature
16. Alarm, coolant level
17. Fuel alarm
18. Diagnostic lamp
19. Overspeed indicator (Genset)
20. Operation indicator (Genset)
21. Preheating indicator (Versatile)
22. Preheating contact, non-locking (Versatile)
23. 8-pin Deutsch connection pin
24. Regulator (contact), two-position
25. Charge indicator
26. Termination 120 W
27. 8-pin Deutsch connection sleeve
28. Control Interface Unit (CIU)

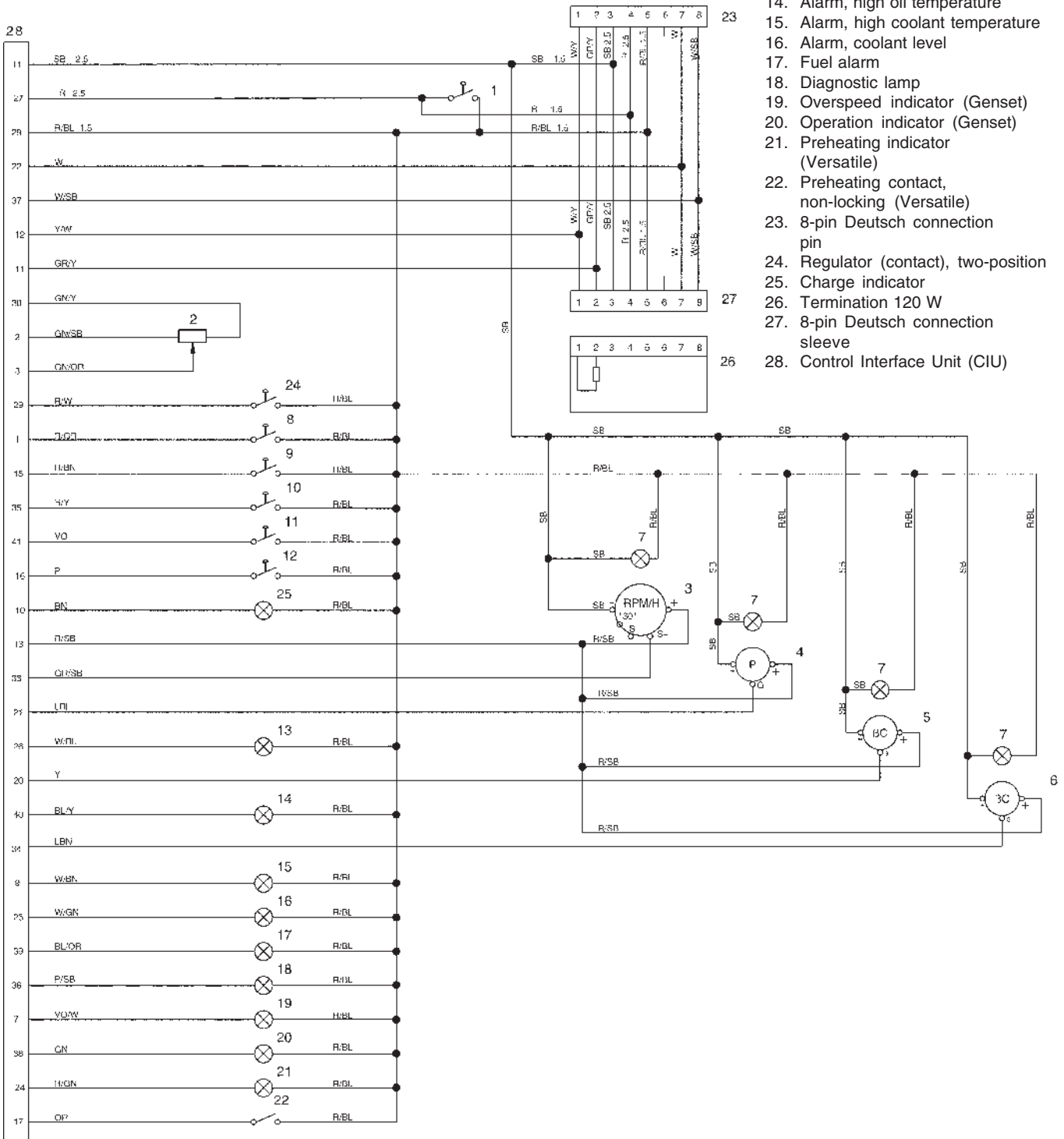

Wiring diagram, Control Interface Unit (CIU) – Power pack

1. Activating operating power, contact (15+)
2. RPM potentiometer
3. Tachometer code 14
4. Oil pressure, instrument
5. Coolant temperature, instrument
6. Instrument illumination
7. Starter contact, non-locking
8. Stop contact, non-locking
9. Diagnosis contact, non-locking
10. Charge indicator
11. Alarm, high oil temperature
12. Alarm, high coolant temperature
13. Alarm, coolant level
14. Fuel alarm
15. Diagonotic lamp
16. Preheating indicator
17. 8-pin Deutsch connection pin
18. 8-pin Deutsch connection sleeve
19. Horn total alarm
20. Preheating contact, non-locking function (option)
21. 42-pin connector
22. Termination 120 W
23. Extra outlet for 24 V and stop
24. Control Interface Unit (CIU)

Cable colors

BL = Blue	P = Pink
LBL = Lightblue	R = Red
BN = Brown	SB = Black
LBN = Light brown	VO = Violet
GN = Green	W = White
GR = Gray	Y = Yellow
OR = Orange	

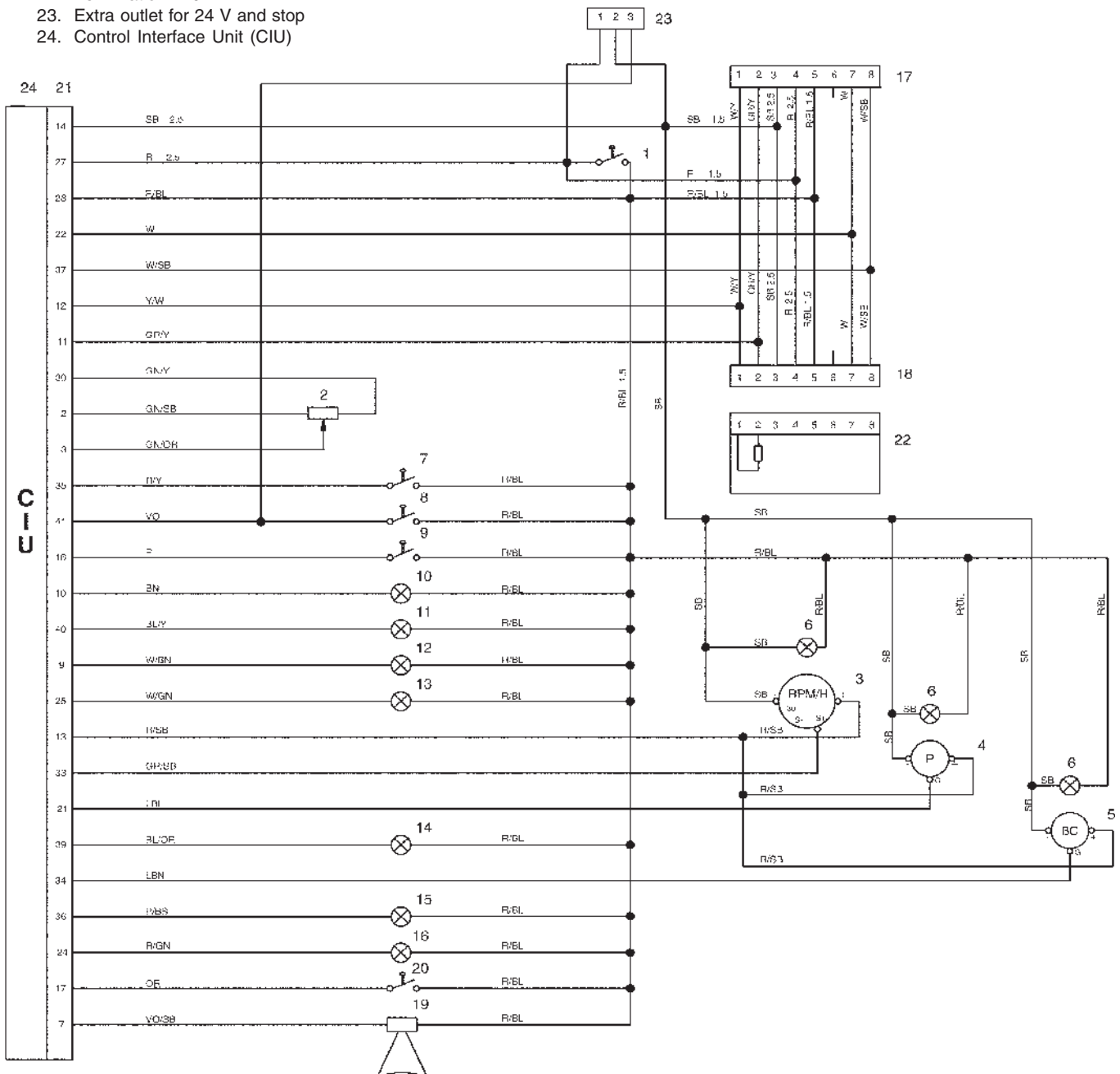

Index

A		O	
About the Service Manual	5	Our common responsibility	6
C		P	
Certified engines	5	PC diagnostics program	25
Check/fault detection of components	49	R	
Component description, sensors and monitors	14	Reading out error codes	27
Component diagram and location	18	Repair instructions	6
Control Interface Unit (CIU)	16	Repair instructions	22
Control module (EMS)	16	S	
Control module (EMS), replacement	23	Safety information	2
D		Sealants	7
Design and operation	12	Spare parts	5
Diagnostic function affects the engine	27	Special tools	9
Diagnostic function	27	Splicing of electrical cable for cable glove	48
E		Start with booster batteries	24
Electrical system	62	Starter motor	17
Electrical system, overview	63	Strength classes	7
Electronic fault detection	46	Symptoms and possible causes	26
Erasing error codes	28	System description EDC III	12
F		T	
Fault codes EDC III	29	Technical data	10
Fault detection of cables and connectors	47	The role of diagnostic function	27
Fault detection	26	Tightening torques	6
Functionality check of lines and connectors	46	Torque-angle tightening	7
Functionality check	25	U	
G		Unit injectors	17
General	8	W	
General information	5	When working with EDC III	22
General	46	Wiring diagram TAD1240-42GE/VE	66
Generator	17	Wiring diagram TWD1240VE	67
I		Wiring diagram, Control Interface Unit (CIU) - Power pack	69
Important about the electrical system	62	Wiring diagram, Control Interface Unit (CIU)	68
Introduction	2	L	
L		Limit values	19
Limit values, control unit (ECU) TAD1240-42GE/VE	19	Limit values, control unit (ECU) TWD1240VE	20
Limit values, control unit (ECU) TWD1240VE	20	Limp-home values	21
Limp-home values	21	Location of engine plates	8
Location of engine plates	8	Lock nuts	7
Lock nuts	7		