

USE AND MAINTENANCE
FPTN67TM4

FPT N67 TM4

G-DRIVE ENGINES

<http://www.brizmotors.ru/equipment/iveco/gen160ma/>



ENGINE TECHNICAL DATA NEF67TM4

The technical code and serial number are specified on the nameplate positioned on different parts of the engine, depending on the model: flywheel case, tappet cover, coolant tank, etc.

Code	NEF67TM4
Engine family	F4
Cycle	Diesel 4-stroke
Number and arrangement of cylinders	6, in line
Bore x stroke	104 x 132 mm
Total displacement	6,728 cm ³
Air supply	Supercharged with turbocharger + intercooler
Injection method	Direct injection with rotary pump
Compression ratio	17.5:1
Cooling	Liquid
Engine rotation direction	Anti-clockwise (flywheel side view)
Control system	Mechanical
Dry weight	~640 kg (G-Drive)

Electric system	12 V
Battery capacity	100 Ah
Pick-up current	60 A

Electric system	12 V
Maximum input	3 kW
Discharge current (EN 50342)	650 A

Performance (*)	NEF67TM4	
Non emissions certified	50 Hz	Prime 149.7 kWm @ 1,500 rpm Stand-by 165 kWm @ 1,500 rpm
	60 Hz	Prime - kWm @ 1,800 rpm Stand-by - kWm @ 1,800 rpm
Engine idle speed unladen	50 Hz	1,500 rpm
	60 Hz	- rpm
Maximum engine rpm unladen	50 Hz	1,570 rpm
	60 Hz	- rpm



It is strictly forbidden to alter the aforesaid characteristics and, in particular, to modify the calibration of the injection pump or the characteristics of the engine and its components. Failure to comply with the above shall result in the loss of warranty, in addition to FPT declining all responsibility.

(*)Net power at the flywheel in accordance with the standard ISO 8528. Test conditions: T 25 °C; atmospheric pressure 100 kPa; relative humidity 30%.

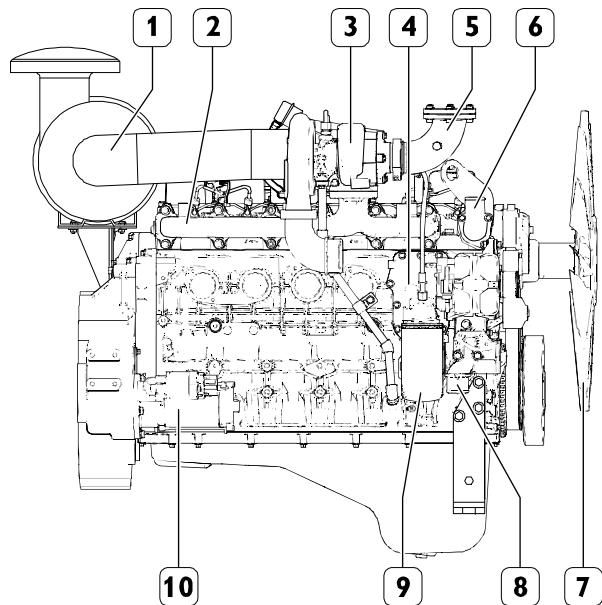

14_203_N

NEF67TM4

1. Comburent air intake duct to turbocharger - 2. Exhaust manifold - 3. Turbocharger - 4. Heat exchanger lubricant oil / coolant - 5. Exhaust gas outlet duct from turbocharger - 6. Engine coolant outlet pipe - 7. Fan (radiator) - 8. Engine coolant inlet pipe - 9. Oil filter - 10. Electric starter motor.

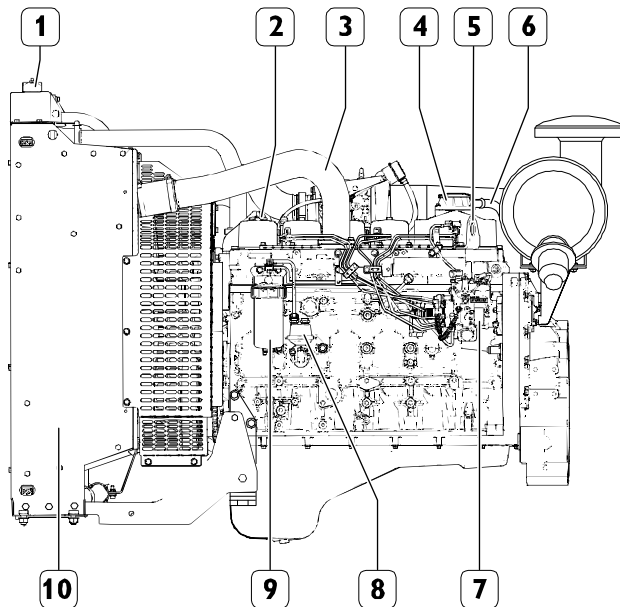

14_204_N

NEF67TM4

1. Coolant inlet plug - 2. Lubricant oil filler cap - 3. Comburent air intake duct to engine - 4. Control valve (blow-by) - 5. Lifting eyelet - 6. Oil vapour breather pipe - 7. Rotary fuel supply pump - 8. Fuel suction pump - 9. Fuel filter - 10. Heat exchanger external air / coolant.

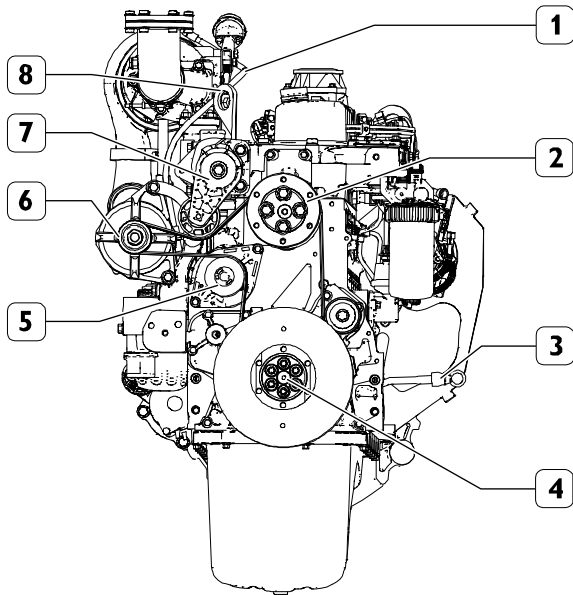

14_205_N

NEF67TM4

1. Turbocharger lubrication oil delivery pipe - 2. Fan control pulley -
 3. Oil level dipstick - 4. Crankshaft pulley - 5. Water pump -
 6. Alternator - 7. Automatic belt tensioner - 8. Lifting eyelet.

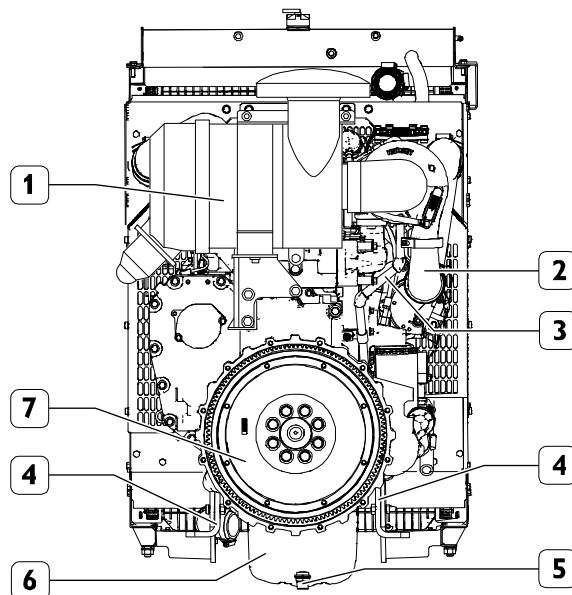

14_206_N

NEF67TM4

1. Air filter - 2. Combustor air intake duct to intercooler - 3. Lubricant
 oil return pipe from turbocharger - 4. Engine mounts - 5. Lubricant oil
 drain plug - 6. Oil sump - 7. Engine flywheel.

LABELS

Some warning labels (below the description) are affixed to the engine.

Note: labels containing an exclamation mark highlight a potential danger.



Hoisting point (engine only).



Fuel filling cap
(on the tank, if present).



Lubricant oil filling cap.



Lubricant oil level dipstick.



Risk of burns:
Expulsion of pressurized hot water.



Risk of burns:
Presence of parts at high temperature.



Risk of fire:
Presence of fuel.



Risk of injury
from moving parts:
Presence of fans, pulleys, belts and other
objects.

■ USE

PRELIMINARY CHECKS

Each time before starting the engine:

- ❑ Check and top up the level of the technical fluids, if necessary (fuel, engine oil and coolant).
- ❑ Make sure that the air intake filter is not obstructed or clogged and check, at the same time, that the visual indicator (1) on the filter is not showing the "red" signal. The air filter clogging visual indicator (1) signals when it is necessary to carry out maintenance in order to protect and optimize filter operation. The sensor (1) remains locked in the alarm position ("red") until it is reset.

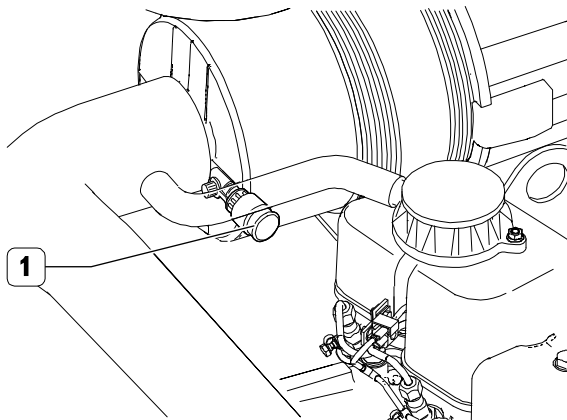

14_207_N

Note: the required procedures for filter cleaning are specified in the chapter CHECKS AND MAINTENANCE.

ATTENTION!



Make sure that the environment where the engine will operate is free of combustible vapours or gases. Make sure that there is sufficient ventilation and a suitable exhaust gas extraction system for closed environments.

ENGINE PRE-HEATING (optional)

The engines which require low start-up temperatures and an immediate delivery of power may be equipped with an electrical heating device enabling an increase in the temperature of the air entering the engine. The device is mounted on the intake manifold and is fitted with a coolant temperature sensor which interrupts the power supply once the required temperature has been reached.

SWITCHING OF OPERATING FREQUENCY

Based on the specific operational requirements of the engine, it is possible to vary the adjustment of the rotary injection pump so as to obtain a different operating frequency:

- 1,500 rpm @ 50 Hz
- 1,800 rpm @ 60 Hz

To switch from 50 Hz to 60 Hz it is necessary to turn the adjustment screw (1) of the "droop setting", clockwise a number of turns depending on the identification code of the pump indicated on the nameplate.

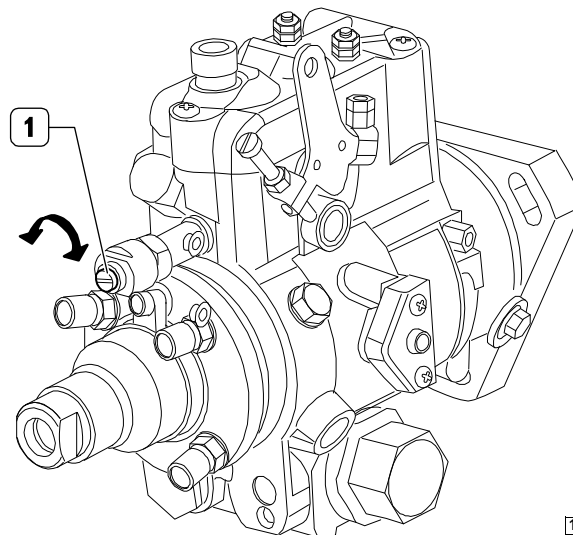

13 066 N

FOR PROPER ENGINE USE

- ❑ Check there is sufficient fuel in the tank before each start.
- ❑ Avoid prolonging the duration of the start control.
- ❑ Do not idle for long periods since this increases the production of harmful emissions from the engine and does not guarantee its optimum performance.
- ❑ The engine speed must be increased and decreased gradually so as to permit normal combustion and the optimum functioning of all engine components.
- ❑ During use, check periodically that:
 - the temperature of the engine coolant does not reach the alarm thresholds;
 - the oil pressure remains within normal values.
- ❑ The speed and power values must comply with that specified in the technical-commercial documentation.
- ❑ Particular attention must be paid to engines that equip the emergency generating units for which frequent efficiency checks are required in order to guarantee their prompt start in all cases when required.

SPECIAL WARNINGS

High coolant temperature

In the event of an excessive temperature or the signalling of the alarm, disengage the load and stop the engine in order to check the condition of the cooling circuit.

Also check and have the following checked:

- ❑ the condition of the ancillary belt;
- ❑ the operation of the thermostatic valve;
- ❑ the cleanliness of the heat exchanger (radiator).

ATTENTION!



*When the engine is hot, pressure builds up in the cooling circuits which may eject hot liquid violently, resulting in a risk of burns.
Open the filler cap of the coolant tank only if necessary and only when the engine is cold.*

Low lubricant oil pressure

Should the pressure indicated by the instrument be considered insufficient or if the "low oil pressure" warning light comes on, stop the engine and check the oil level. If necessary, top up the oil according to the instructions contained in the section CHECKS AND MAINTENANCE. If the fault persists, contact a Service centre.

Presence of water in the fuel filter

It is advisable to drain the water from the filters before the relevant warning light comes on.

Do not use the engine if the tank only contains the quantity of fuel kept as reserve; this condition promotes the formation of condensate and the intake of sludge or air, causing the engine to stop.



Refuelling from drums or jerry cans may contaminate the diesel, resulting in problems with the fuel supply system; in these cases it is necessary to carry out adequate filtration or sedimentation of any impurities present.

ATTENTION!



The couplings of the fuel circuit under high pressure must not be loosened under any circumstances

Intake and exhaust circuit inefficiencies

Regularly inspect the cleanliness of the air intake circuit. The maintenance intervals indicated in this manual change with the conditions of use.

Maintenance checks must be performed more frequently in particularly dusty environments with regard to that stated in the chapter CHECKS AND MAINTENANCE.

ATTENTION!



Visually check that the exhaust circuit is not obstructed or damaged to prevent noxious and dangerous fumes.

Electrical start-up system irregularities

Periodically check the cleanliness and efficiency of the batteries, particularly during winter, by performing the checks and top-ups as described in the chapter CHECKS AND MAINTENANCE.

In the event of battery replacement, please observe the characteristics contained in the section ENGINE TECHNICAL DATA.



If the voltmeter indicates a voltage value lower than 11 V (for nominal 12 V systems), or 22 V (for nominal 24 V systems), contact a specialised workshop and have the efficiency of the batteries and charging system diagnosed.

CAPACITIES

NEF67TM4



The batteries contain an acid solution, which is caustic to skin and corrosive for garments; while checking them, wear protective garments, gloves and goggles, do not smoke or permit open flames to come near them and make sure that the room where they are located is suitably ventilated.

Battery or alternator recharging faults

Check or have checked periodically the state of cleanliness, wear and the correct movement of the drive belt.

ATTENTION!



The ancillary members are located under protective grilles. Their removal must be carried out only when the engine is not turning.

RUN-IN

Thanks to modern engine construction technologies, a particular run-in procedure is not required. However, it is recommended to avoid using the engine at high power for long periods during the first 50 hours.

Parts to be refilled	litres (kg)	
Cooling circuit ⁽¹⁾	engine ⁽⁴⁾	10.5
	G-Drive ⁽⁵⁾	25.5
Lubrication circuit ^{(2) (3)}		17.2 (15.8)
Periodic replacement:		
Sump at minimum level		8 (7.4)
Sump at maximum level		12 (11)

- (1) Use a 50% mixture of water and PARAFU 11 or the equivalent corresponding to the specification SAE J1034.
- (2) Use lubricants which comply with the international specifications ACEA E5-E7 (high power engines). Oil consumption is considered acceptable up to quantities of 0.1% of fuel consumption.
- (3) The quantities indicated refer to the first filling only and concern the engine, oil sump and filter.
- (4) The quantities indicated only refer to the engine in its standard configuration.
- (5) The quantities indicated refer to the total capacity of the generating unit including the capacity of the engine, radiator and pipes.

Coolant refilling

For the initial engine start-up and in the cases in which the refilling of the cooling circuit is required with a considerable quantity of coolant, proceed as follows:

- ❑ Refill the engine and the exchanger until the exchanger is completely filled.
- ❑ With the coolant filler plug open, start the engine and let it idle for approx. 1 minute. This helps to completely bleed the air contained in the cooling circuit.
- ❑ Stop the engine and then top up with coolant if necessary.



The failure to observe the aforesaid procedure does not guarantee the presence of the correct quantity of coolant in the engine.

ATTENTION!



When the engine is hot, pressure builds up in the cooling circuits which may eject hot liquid violently, resulting in a risk of burns. Open the filler cap of the coolant tank only if necessary and only when the engine is cold.

Refuelling

Use only diesel oil in accordance with EN 590 standard normally commercially available. Fuel additives are not recommended. Use of additives can limit the guarantee performance offered for the vehicle.

ATTENTION!



Pay maximum attention when refuelling, making sure that solid or liquid pollutants do not enter the tank; please remember that smoking is prohibited while refuelling. The couplings of the fuel circuit under high pressure must not be loosened under any circumstances.

Diesel oil for low temperatures

At low temperatures the degree of fluidity of the diesel can become low due to the separation of the paraffin resulting in the filters becoming clogged.



Standard EN590 defines different diesel classes, identifying the characteristics of those most suitable for use at low ambient temperatures.

It is entirely the responsibility of the oil companies to comply with the regulations regarding the distribution of fuels suitable for the climatic and geographical conditions of the various countries.

■ CHECKS AND MAINTENANCE

MAINTENANCE PERSONNEL

The engine check and maintenance operations specified in this chapter require preparation, skill and compliance with safety standards; therefore, they must be carried out by responsible personnel, as indicated below.

- ❑ **Checks to be made during periods of use:** by workshop personnel or if necessary by the machine user.
- ❑ **Periodic maintenance:** by qualified personnel equipped with proper work tools and suitable protections. 
- ❑ **Unscheduled maintenance:** by qualified Service Centre personnel in possession of precise technical information and specific equipment. 

The most qualified Service Centres are those included in the FPT Technical Support Network.

ACCIDENT PREVENTION

- ❑ Always wear safety footwear and overalls.
- ❑ Do not wear loose clothing, rings, bracelets and/or necklaces near the engines or moving parts.
- ❑ Wear protective gloves and goggles while:
 - filling the batteries with acid solution
 - check cleanliness of battery clamps and terminals
 - filling up inhibitors or antifreeze

- changing or filling the lubricant oil (hot engine oil can cause burns). It is recommended to perform these operations only when their temperature is lower than 50 °C).
- ❑ When working in the engine compartment, pay maximum attention to all movements to avoid coming into contact with rotating or hot components.
- ❑ Wear goggles when using compressed air (the maximum air pressure used for cleaning is 200 kPa (2 bar, 30 psi, 2 kg/cm²).
- ❑ Wear a protective helmet if working in an area with suspended loads or overhead systems.
- ❑ Use protective creams for hands.
- ❑ Immediately replace wet overalls.
- ❑ Always keep the engine clean, removing spots of oil, diesel and coolant.
- ❑ Return oily rags to fire-proof containers.
- ❑ Do not leave foreign objects on the engine.
- ❑ Use adequate and safe containers for the spent oil.
- ❑ At the end of a repair, implement suitable measures to stop air intake by the engine if, after starting, the engine runs at uncontrolled speeds.



Do not perform maintenance in the case of live electrical voltage: check the condition of the equipment's ground connection. During the diagnostics and maintenance operations, make sure your hands and feet are dry and use insulating footboards if possible.



The conditions that cause an emergency generator set to start can occur suddenly. While performing checks and maintenance, comply strictly with the requirements indicated by the Manufacturer of the generator set and by the Fitter of the electric generation system to ensure maximum safety for maintenance personnel.

FREQUENCIES

NEF67TM4

Checks in periods of use	Frequency
Check the engine lubricant oil level	Daily
Check engine coolant level	Daily
Check the cleanliness of the heat exchanger (radiator)	Daily
Inspection of the exhaust duct/s	Daily
Inspection of air filter	Monthly ⁽²⁾
Check tightening and cleanliness of battery clamps	Six-months
Check electrolyte level of the batteries	Six-months
Check condition of the blow-by filter	Six-months

The frequencies indicated below take into account factors of use of different engine uses; the most suitable duration of the maintenance intervals for the different applications will be indicated by the maintenance personnel based on the use and operating conditions of the engine.



Periodic maintenance

Frequency

Change engine lubricant oil	800 hours ⁽³⁾ ⁽⁴⁾
Change oil filter	800 hours ⁽³⁾ ⁽⁴⁾ ⁽⁵⁾
Replace the fuel filter	600 hours ⁽¹⁾ ⁽⁴⁾ ⁽⁵⁾
Drain the water from the fuel filter	150 hours ⁽¹⁾
Drainage/suction of water, condensation and impurities from the fuel tank/s	150 hours ⁽¹⁾
Change blow-by filter	900 hours
Change the engine coolant	1200 hours / 2 years
Change air filter	1200 hours / 2 years ⁽²⁾



Unscheduled maintenance

Frequency

Change the auxiliary device belt	1200 hours / 3 years
Visual inspection of turbocharger	1200 hours
Clean the heat exchanger (radiator)	1200 hours
Injector calibration	1800 hours
Adjustment of valve/rocker arm clearance	3000 hours

- 1) Maximum period relating to the use of high quality fuel, (specification EN 590); which is reduced in the event of fuel contamination and alarm signals caused by filter clogging and/or the presence of water in the filter. The filter clogging signal indicates that the filter must be replaced. If the warning light of water present in the filter does not go off after drainage, then the filter must be replaced.
- 2) The frequency depends on the ambient conditions and product efficiency/wear. After long periods of engine inactivity, perform the check before starting the engine.
The filter clogging signal indicates that the filter must be replaced.
- 3) The frequencies are applicable for lubricants which meet the international standards ACEA E5-E7 (high power engines)
- 4) To be performed every year even if the specified operating hours interval has not been reached.
- 5) Only use filters with the following specifications:
 - degree of filtering < 12 μm
 - filtering efficiency 99.5% ($\beta > 200$).



In the event in which fuel is used with a sulphur percentage greater than 0.5%, or oils are used which do not meet the specifications in the section FLUIDS, then the replacement frequencies of the engine oil, engine oil filter and blow-by filter must be halved, or suitably adjusted, in accordance with the use and operating conditions of the engine; please consult the personnel in charge of maintenance operations for appropriate advice.



The operations described above require the use of specific tools which guarantee safe and effective results.

It is recommended that such operations are carried out by qualified personnel of the FPT Technical Service Network.

The unscheduled maintenance operations described in the relative table are under the exclusive responsibility of qualified personnel in possession of suitable technical information and equipped with suitable work tools and protective devices. The instructions for their fulfilment are contained in the FPT technical and repair manuals.

REQUIREMENTS

- Do not disconnect the battery supply while the engine is running.
- Do not perform arc welding near the engine without first removing its electrical wiring.
- After all maintenance operations that require disconnection of the batteries, make sure the clamps have been securely reconnected on the poles.
- Do not use a battery charger to start the engine.
- Do not paint the devices, components and electrical connectors of the engine equipment.
- Electrically disconnect the battery/batteries before performing any electrical work.
- Contact the Manufacturer before installing any electronic equipment.



*Do not perform any operation that would change the calibration of the injection pump.
It was adjusted during the engine test phase and based on its destination.*

CHECKS TO BE MADE DURING PERIODS OF USE – HOW TO PROCEED

Check the engine lubricant oil level

Only proceed when the engine is not turning and is at low temperature in order not to run the risk of burns.

- ❑ Use the oil level dipstick (1) to check that the lubricant oil level is between the "Min" and "Max" limits.
- ❑ If the level is insufficient, it is necessary to top up with lubricant oil which meets the international specifications ACEA E5-E7 (high power engines), as indicated in the section FLUIDS: remove the lubricant oil cap (2) and pour engine lubricant oil through the hole.
- ❑ Use the oil level dipstick (1) to check that the quantity of lubricant oil does not exceed the "Max" limit.

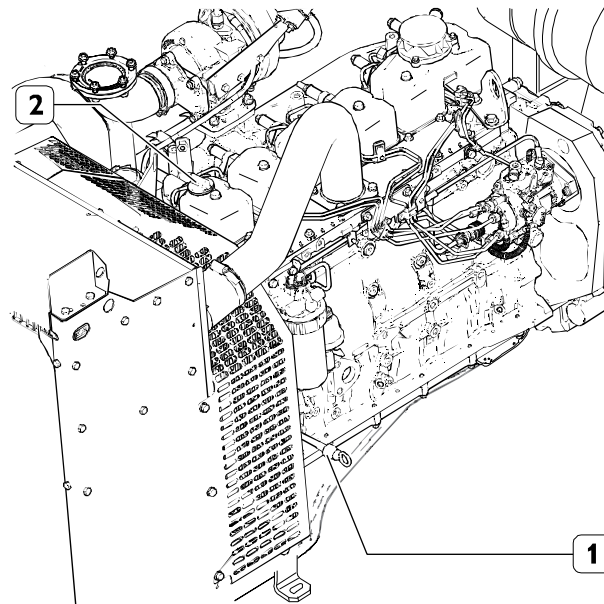

Make sure that the oil dipstick is fully inserted and that the oil filler cap is fully tightened in a clockwise direction.

14 208 N

Check engine coolant level

Only proceed when the engine is not turning, and is at low temperature, so as not to run the risk of burns.

- ❑ Remove the pressurization cap from the expansion tank.
- ❑ Check that the coolant in the expansion tank is above the minimum level.
- ❑ If necessary, top up the expansion tank with a mixture of 50% water and PARAFLU 11, as contained in the section FLUIDS. Do not fill the expansion tank to the brim.
- ❑ When the engine is cold, make sure that the coolant in the expansion tank is a few centimetres below the filling hole.

In the event of an externally located level indicator as regards the heat exchangers, proceed with the top up operation by making sure that the coolant does not overflow the internal volume of the exchanger in order to allow the expansion of coolant volume during increases in temperature.

Check the cleanliness of the heat exchanger (radiator)

Check that the air intake surfaces of the radiators are free of impurities (dust, mud, straw etc.).

Clean them if necessary using compressed air or steam.

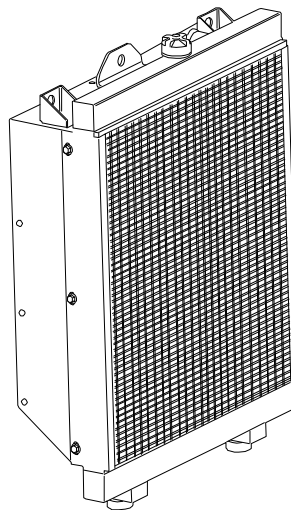

13_068_N



If frequent coolant top-ups are necessary, the cooling circuit must be diagnosed.

ATTENTION!



When the engine is hot, pressure builds up in the cooling circuits which may eject hot liquid violently, resulting in a risk of burns.

Open the filler cap of the coolant tank only if necessary and only when the engine is cold.



When using compressed air, it is required to use suitable personal protections for hands, face and eyes. The requirements can be found in the ACCIDENT PREVENTION paragraph.

Inspection of the exhaust duct/s

Visually check that the exhaust gas / exhaust system is not obstructed or damaged.

- ❑ Make sure that there is no risk of harmful fumes in the environment where the engine is being worked on. Contact the manufacturer if necessary.

Inspection of air filter

Only proceed when the engine is not turning over.

- ❑ Remove the cover (3) of the air filter after having undone the two quick release catches (2).
- ❑ Remove the filter element (1); make sure that dust does not enter the sleeve during this operation.
- ❑ Make sure there are no impurities. Otherwise, clean the filter element according to the instructions provided below.
- ❑ Blow dehumidified compressed air on the filtering element, working from the inside outwards (maximum pressure 200 kPa).
- ❑ Check the condition of the air filter before refitting it. Replace it if broken or torn.
- ❑ Check the condition of the gasket at its base.
- ❑ Position the filter element (1) in its seat.
- ❑ Replace the cover (3) of the air filter and lock it using the two quick release catches (2).



Do not use detergents or diesel to clean the air filter. Never strike the filter element with tools. The imprecise assembly of the air filter may result in the intake of unfiltered air and therefore cause serious damage to the engine.

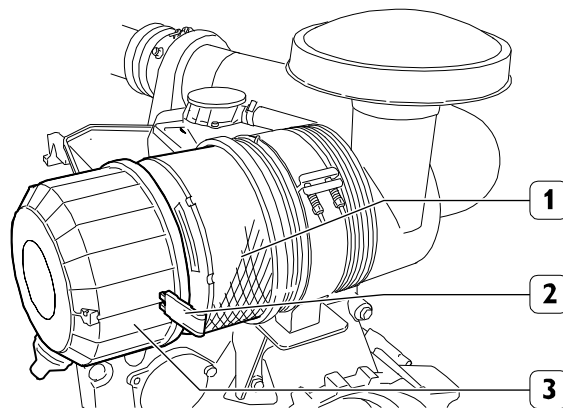

14_209_N

Check tightening and cleanliness of battery clamps

Check that the battery terminals and cable clamps are clean, well tightened and protected by Vaseline.

In the event of dirty cable clamps and battery terminals:

- ❑ Loosen the nut and remove the clamp from the negative terminal (marked with a "-").
- ❑ Loosen the nut and remove the clamp from the positive terminal (marked with a "+").
- ❑ Use a wire brush or fine grade sand paper to clean the cable clamps and the battery terminals until they are shiny.
- ❑ Smear the cable clamps with Vaseline and insert them onto the battery terminals making sure that the positive pole is connected first, followed by the negative pole, and then tighten each clamp.

Check the cables and clamps for signs of wear and corrosion; replace them if in poor condition.

Visually check the condition of the battery: the terminals must not show signs of deterioration and the body must not be damaged, otherwise they should be replaced.

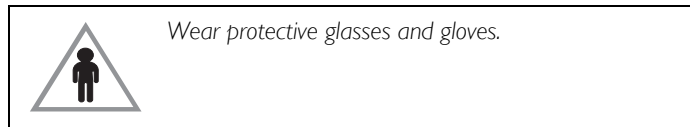

Check electrolyte level of the batteries

The batteries used are of reduced maintenance type. Therefore, under normal conditions of use, no top up of the electrolyte is required. However, the routine checking of the electrolyte level is recommended. Proceed after positioning the batteries on a horizontal surface.

- ❑ Visually check that the electrolyte level is between the "Min" and "Max" reference marks on the batteries; in the absence of any reference marks, make sure the liquid covers the lead plates contained in the elements by approx. 5 mm.
- ❑ Only use distilled water to top up the elements whose level is below the minimum.
- ❑ If the battery must be recharged, contact a specialised workshop.

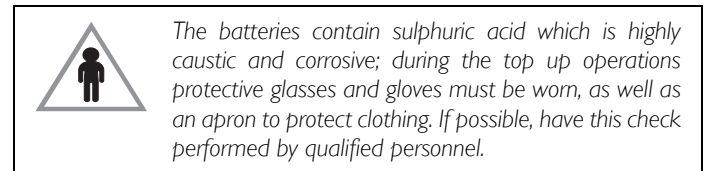
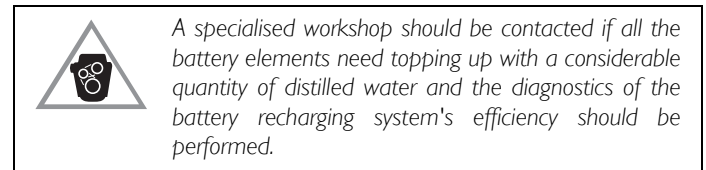

ATTENTION!



During the checks do not smoke or allow naked flames near the batteries. Ensure that the work area is suitably ventilated.

Some batteries have a single cover for the inspection plugs. To access the elements, use a lever as shown in the figure.

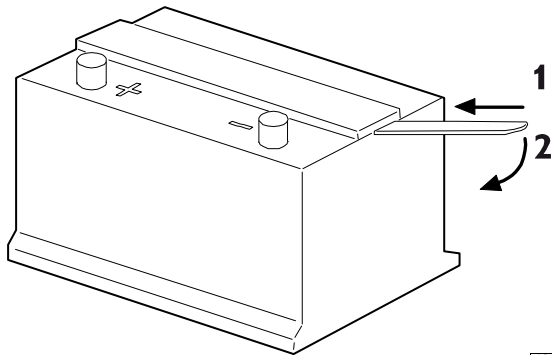

13 078 N

Check condition of the blow-by filter

Only proceed when the engine is not turning over.

Disconnect the oil vapour recovery pipe from the blow-by filter (2). Remove the screws (1) and detach the blow-by filter (2) from the cylinder tappet cover 5-6 (3); retain the seal.

Check that the blow-by filter (2) is not clogged; Otherwise replace it. Clean the contact surfaces carefully.

Install the seal and fit the blow-by filter (2) on the cylinder tappet cover 5-6 (3).

Tighten the screws (1).

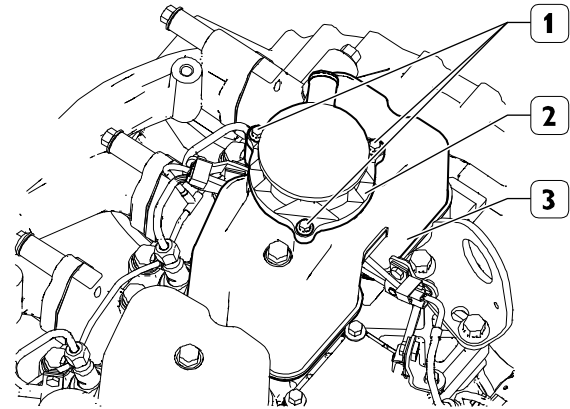

14 214 N

PERIODIC MAINTENANCE - HOW TO PROCEED

Change engine lubricant oil

Only proceed when the engine is not turning and is at low temperature so as not to run the risk of burns.

- ❑ Place a suitable container for collecting the spent oil under the oil sump next to the lubricant oil drain plug (see the figures in the section ENGINE TECHNICAL DATA).
- ❑ Unscrew the lubricant oil drain plug; afterwards extract the oil level dipstick (1) and remove the lubricant oil cap (2) to assist the flow of the engine lubricant oil.
- ❑ Wait until the oil sump has completely emptied, then retighten the lubricant oil drain plug.
- ❑ Proceed with the refilling operation through the hole situated on the tappet cover of cylinder no. 1, using lubricant oil that meets the international standards ACEA E5-E7 (high power engines), as indicated in the section FLUIDS.
- ❑ Use the oil level dipstick (1) to check that the quantity of lubricant oil does not exceed the "Max" limit.
- ❑ Retighten the lubricant oil cap (2).
- ❑ Together with the replacement of the engine lubricant oil it is necessary to replace the oil filter (see paragraph OIL FILTER REPLACEMENT).

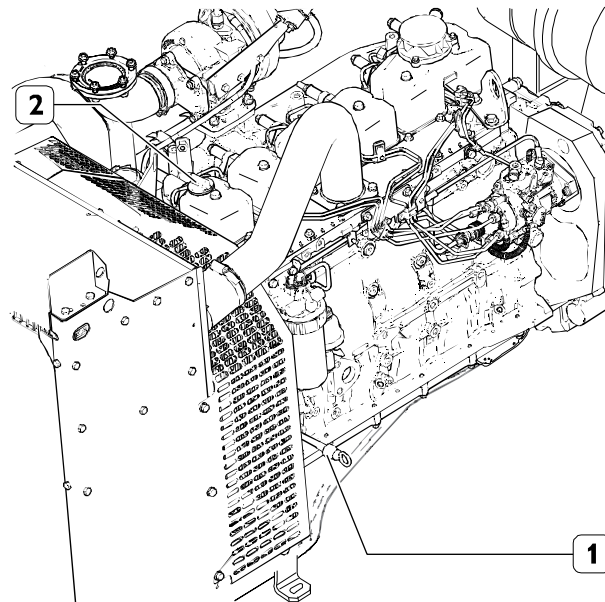

*Eliminate the consumables and any materials in contact with them (for example, filters) in accordance with current regulations.
The FPT Technical Service Network workshops are equipped for this purpose.*



Make sure that the oil dipstick is fully inserted and that the oil filler cap is fully tightened in a clockwise direction.

Change oil filter

Only use filters with the following specifications (see the section FREQUENCIES):

- degree of filtering <math>< 12 \mu\text{m}</math>
- filtering efficiency 99.5% ($\beta > 200$).

Only proceed when the engine is not turning and is at low temperature so as not to run the risk of burns.

- ❑ Proceed with the emptying of the spent oil (see paragraph CHANGE ENGINE LUBRICANT OIL).
- ❑ Place a container for collecting the spent oil under the filter support (1).
- ❑ Remove the filter (2) by unscrewing it from its relative support.
- ❑ Replace the filter element and the O-ring seal contained inside the filter (2).
- ❑ Carefully clean the surfaces of the support (1) in contact with the O-ring seal.
- ❑ Moisten the O-ring seal of the new filter with oil.
- ❑ Screw the new filter (2) onto the support (1).

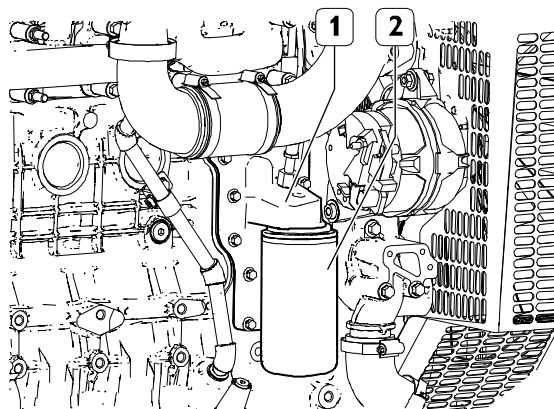

14_210_N



*Eliminate the consumables and any materials in contact with them (for example, filters) in accordance with current regulations.
The FPT Technical Service Network workshops are equipped for this purpose.*

Fuel filter change

Only use filters with the following specifications (see the section FREQUENCIES):

- degree of filtering <math>< 12 \mu\text{m}</math>
- filtering efficiency 99.5% ($\beta > 200$).

Only proceed when the engine is not turning and is at low temperature so as not to run the risk of burns.

- ❑ Place a container for collecting the diesel under the filter support (1).
- ❑ Remove the filter (2) by unscrewing it from its relative support.
- ❑ Replace the filter element and the O-ring seal contained inside the filter (2).
- ❑ Carefully clean the surfaces of the support (1) in contact with the O-ring seal.
- ❑ Moisten the O-ring seal of the new filter with oil.
- ❑ Screw the new filter (2) onto the support (1)

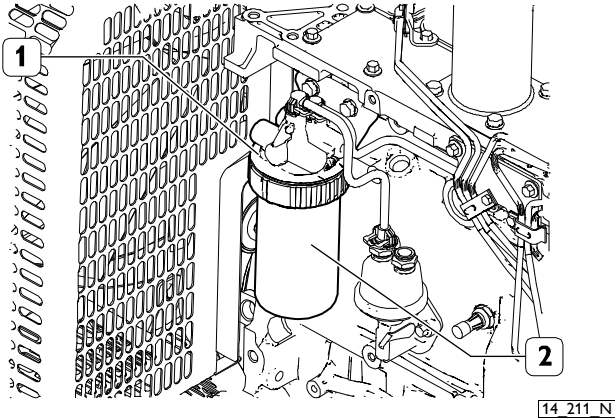

Residual air bleeding procedure:

- ❑ Loosen the fuel outlet coupling (1) located on the top of the filter.
- ❑ Make sure that the discharge of diesel does not soil the ancillary belt and does not leak into the surroundings.
- ❑ Operate the lever (3) of the fuel suction pump (2) until the diesel coming out is free from any residual air.
- ❑ Correctly tighten the previously loosened coupling.
- ❑ Start the engine and let it run idle for a few minutes to remove any residual air.

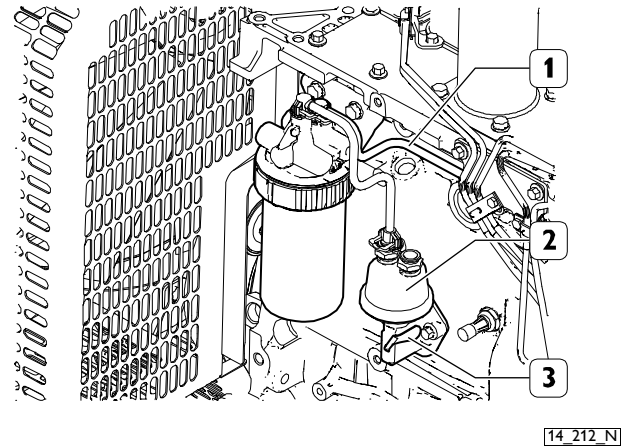



Do not fill the new fuel filter before placing it on the support in order to prevent harmful impurities from entering the fuel circuit and the injection system.



*Eliminate the consumables and any materials in contact with them (for example, filters) in accordance with current regulations.
The FPT Technical Service Network workshops are equipped for this purpose.*

Drain the water from the fuel filter

In the case of a high risk of refuelling with fuel polluted with foreign agents and water, the following check should be performed at each refuelling.

Only proceed when the engine is not turning over.

- Place a container for collecting liquids under the fuel filter.
- Unscrew the valve plug (1) located at the bottom of the filter; in some versions, the plug includes the water in diesel sensor.
- Drain the liquid until only "diesel" is released.
- Fully retighten the plug manually.
- Dispose of the drained liquids according to the applicable regulations in force.

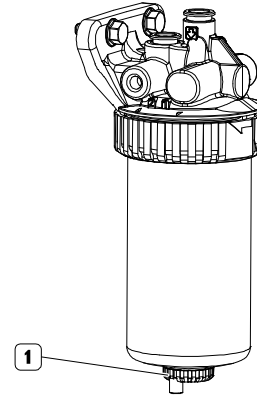

12_020_G

Drainage/suction of water, condensation and impurities from the fuel tank/s

Perform the drainage/suction of water, condensation and impurities from the fuel tank/s by following the instructions contained in the manual supplied by the tank manufacturer.

Proceed as necessary based on the structure or location of the tank: engines that operate in adverse environments and conditions and/or that are refuelled using drums or jerry cans, require more attention when cleaning the tank.

Change the engine coolant

Only proceed when the engine is not turning, and is at low temperature, so as not to run the risk of burns.

- ❑ Place a container for collecting coolant under the heat exchanger (radiator).
- ❑ Remove the pressurization cap from the expansion tank.
- ❑ Loosen the fastening elements and remove the coupling sleeves connecting the engine cooling circuit to the heat exchanger.
- ❑ Drain the coolant from the heat exchanger (radiator) and wait until it is completely empty.
- ❑ Once emptied, restore the integrity of the cooling circuit, by ensuring the perfect seal of the sleeves.
- ❑ Refill the engine and the heat exchanger until the cooling circuit has been completely refilled using a mixture of 50% water and PARAFU 11, as contained in the section FLUIDS. Do not fill the expansion tank to the brim.

- ❑ With the coolant filler plug open, start the engine and let it idle for approx. one minute. This helps to completely bleed the air contained in the cooling circuit.
 - ❑ Stop the engine and then top up with coolant if necessary.
 - ❑ When the engine is cold, make sure that the coolant in the expansion tank is a few centimetres below the filling hole.
- In the event of an externally located level indicator as regards the heat exchangers, proceed with the top up operation by making sure that the coolant does not overflow the internal volume of the exchanger in order to allow the expansion of coolant volume during increases in temperature.



The failure to observe the aforesaid procedure does not guarantee the presence of the correct quantity of coolant in the engine.



ATTENTION!

When the engine is hot, pressure builds up in the cooling circuits which may eject hot liquid violently, resulting in a risk of burns. Open the filler cap of the coolant tank only if necessary and only when the engine is cold.

Change blow-by filter

Only proceed when the engine is not turning over.

Disconnect the oil vapour recovery pipe from the blow-by filter (2).
Remove the screws (1) and detach the blow-by filter (2) from the cylinder tappet cover 5-6 (3).

Clean the contact surfaces carefully.

Install a new seal and fit the blow-by filter (2) on the cylinder tappet cover 5-6 (3).

Tighten the screws (1).

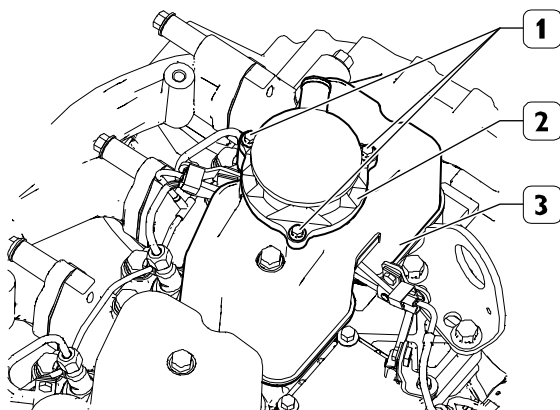

14_214_N

Change air filter

Only proceed when the engine is not turning over.

- Remove the cover (3) of the air filter after having undone the two quick release catches (2).
- Remove the filter element (1); make sure that dust does not enter the sleeve during this operation.
- Replace the filter element and the relative gasket at its base.
- Position the filter element (1) in its seat.
- Replace the cover (3) of the air filter and lock it using the two quick release catches (2).

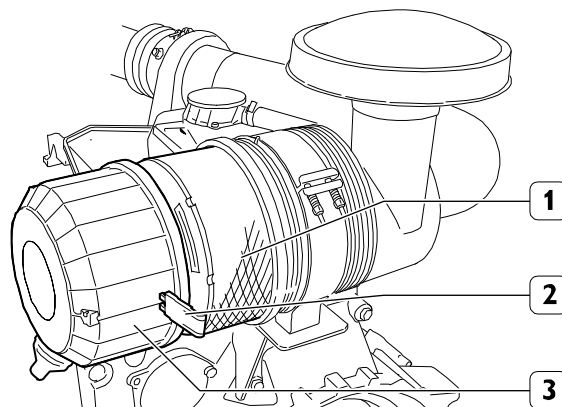

14_209_N



*Do not use detergents or diesel to clean the air filter.
Never strike the filter element with tools.
The imprecise assembly of the air filter may result in
the intake of unfiltered air and therefore cause serious
damage to the engine.*

UNSCHEDULED MAINTENANCE - HOW TO PROCEED

Change the auxiliary device belt

Only proceed when the engine is not turning and is at low temperature so as not to run the risk of burns.

- Remove the protective grilles and the fan together with the spacer by undoing the relative fasteners.
- Act on the automatic belt tensioner (1) and remove the auxiliary device drive belt (6).
- Act on the automatic belt tensioner (1) and force fit the new auxiliary device drive belt (6).
- Check that the belt (6) is inserted correctly inside the alternator pulley (2); also check that the water pump pulley (3), the crankshaft pulley with damper (4), the guide pulley (5) and the fan pulley (7) are inserted correctly.
- Fully rotate the crankshaft twice to ensure that the new auxiliary device drive belt (6) has been correctly fitted.
- Reposition the fan, together with spacer, in its seat and the protective grilles and tighten the relative fasteners.

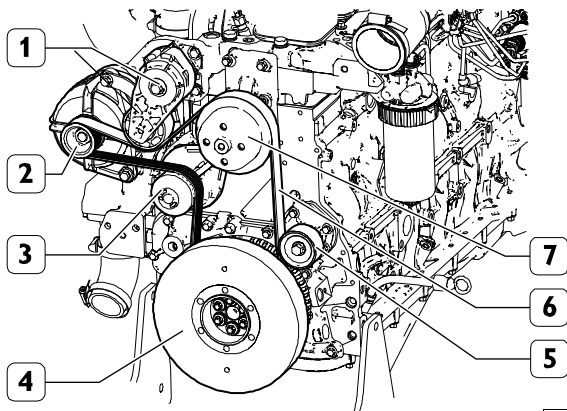

14_213_N

Clean the heat exchanger (radiator)

The surfaces of the heat exchanger (radiator) come into contact with external air and may be subjected to deposits and impurities (dust, mud, straw, etc.). Clean them if necessary using compressed air or steam.

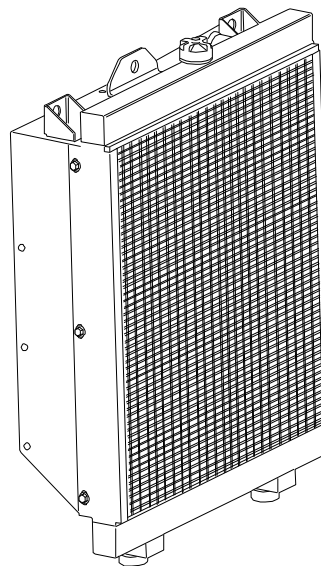

13_068_N



Replace the ancillary belt if it shows signs of abrasions, cracks or tears or if it is soiled with oil or fuel.

ATTENTION!



When the engine is off, but still hot, the belt may start to move without warning. Wait for the engine temperature to decrease to prevent serious danger of an accident.



When using compressed air, it is required to use suitable personal protections for hands, face and eyes. The requirements can be found in the ACCIDENT PREVENTION paragraph

Visual inspection of turbocharger

Only proceed when the engine is not turning over. Visually check that the turbine and compressor impellers and the relative inlet and outlet ducts are not obstructed or damaged, otherwise replace them.

Injector calibration

The injectors require periodic cleaning and calibration of the exact injection pressure, by adding or replacing the shim washers inserted under the spring; check the injection pressure by using a hand operated pump equipped with a pressure gauge which, operated by the lever, enables the injector calibration pressure to be obtained and which is displayed on the pump pressure gauge at the moment in which diesel delivery occurs. During the test it is also possible to note whether the direction of the jet is correct and whether the injectors show any signs of fuel leakage. Clean the injectors using a metal brush to remove the carbon deposits from the nozzle tips.

Adjust valve/rocker arm clearance

The adjustment of the clearance between the rocker arms and the intake and exhaust valve control rods must be strictly carried out using an Allen wrench (1), box-end wrench (3) and a feeler gauge (2).

