

FPT CURSOR 13TE7 (CR13 TE 7W)
Use and Maintenance
Бриз Моторс

CURSOR_{SERIES}

POWER GENERATION

[http://www.brizmotors.ru/
equipment/iveco/ge-cursor-500/](http://www.brizmotors.ru/equipment/iveco/ge-cursor-500/)



ENGINE TECHNICAL DATA

The technical code and serial number are specified on the nameplate positioned on different parts of the engine, depending on the model: flywheel case, tappet cover, coolant tank.

CR13 TE 7 W

Code	CR13 TE 7 W
Engine family	F3HFA615A*D001
Cycle	Diesel 4-stroke
Number and arrangement of cylinders	6, in line
Bore x stroke	135 x 150 mm
Total displacement	12880 cm ³
Compression ratio	16.5:1
Air supply	Supercharged with intercooler
Injection method	Electronically controlled common rail
Max. injection pressure	-
Engine rotation direction	Anti-clockwise (flywheel side view)
Dry weight	1320 kg ⁽¹⁾
Cooling	Water
Control system	Electronic

Electric system	24 V
Recommended battery capacity	2 x 180 Ah
Starter motor maximum output	7.8 kW

Performance ⁽²⁾		CR13 TE 7 W	
Non Emissions Certified	50Hz	Prime Stand-by	415 kWm @ 1500 revs/min 459 kWm @ 1500 revs/min
	60Hz	Prime Stand-by	428 kWm @ 1800 revs/min 474 kWm @ 1800 revs/min

- (1) Approximate dry weight of the basic engine without A/C compressor, oil and coolant
- (2) Power at the flywheel in accordance with directive 97/68 EC (without fan), after 50 hours' operation, tolerance $\pm 3\%$, fuel EN590; Test in compliance with specification ISO 3046/1, turbocharger inlet air temperature 25°C, atmospheric pressure 100 kPa, humidity 30% - Also in compliance with specification DIN 6271, BS 5514, SAE J1349.
All the data are based on engine operation with fuel system, water pump, lubricant oil pump and intake and exhaust restriction within or below, the limits indicated in the "data sheet".
Additional loads estimated at 20 Nm from idle speed to nominal speed.
The fan duty cycle must be less than 20%

WARNING

It is strictly forbidden to alter the aforesaid characteristics and, in particular, to modify the stored data in the injection system's electronic units or the characteristics of the engine and its components. Failure to comply with the above shall result in the loss of warranty, in addition to FPT declining all responsibility.

CR13 TE 6 W

Code	CR13 TE 6 W
Engine family	F3HFA615B*D001
Cycle	Diesel 4-stroke
Number and arrangement of cylinders	6, in line
Bore x stroke	135 x 150 mm
Total displacement	12880 cm ³
Compression ratio	16.5:1
Air supply	Supercharged with intercooler
Injection method	Electronically controlled common rail
Max. injection pressure	-
Engine rotation direction	Anti-clockwise (flywheel side view)
Dry weight	1320 kg ⁽¹⁾
Cooling	Water
Control system	Electronic

Electric system	24 V
Recommended battery capacity	2 x 180 Ah
Starter motor maximum output	7.8 kW

Performance ⁽²⁾		CR13 TE 6 W	
Non Emissions Certified	50Hz	Prime Stand-by	371 kWm @ 1500 revs/min 414 kWm @ 1500 revs/min
	60Hz	Prime Stand-by	400 kWm @ 1800 revs/min 454 kWm @ 1800 revs/min

(1) Approximate dry weight of the basic engine without A/C compressor, oil and coolant

(2) Power at the flywheel in accordance with directive 97/68 EC (without fan), after 50 hours' operation, tolerance ±3%, fuel EN590; Test in compliance with specification ISO 3046/1, turbocharger inlet air temperature 25°C, atmospheric pressure 100 kPa, humidity 30% - Also in compliance with specification DIN 6271, BS 5514, SAE J1349.

All the data are based on engine operation with fuel system, water pump, lubricant oil pump and intake and exhaust restriction within or below, the limits indicated in the "data sheet".

Additional loads estimated at 20 Nm from idle speed to nominal speed.

The fan duty cycle must be less than 20%

WARNING

It is strictly forbidden to alter the aforesaid characteristics and, in particular, to modify the stored data in the injection system's electronic units or the characteristics of the engine and its components. Failure to comply with the above shall result in the loss of warranty, in addition to FPT declining all responsibility.

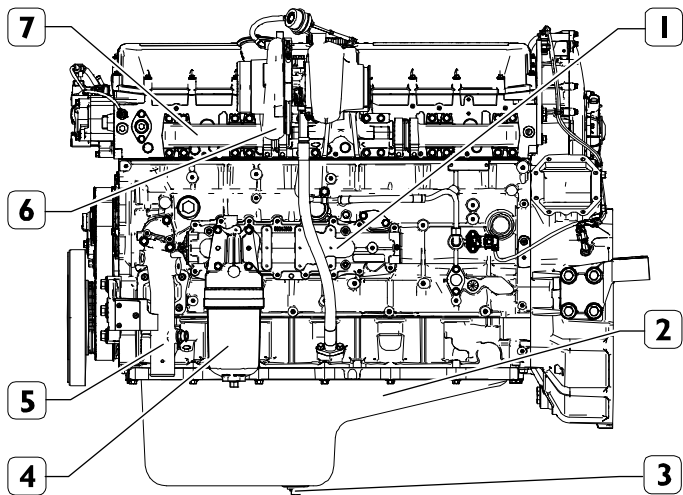

14_172_C

F3HFA615A*D001 - F3HFA615B*D001

- 1. Heat exchanger lubricant oil - 2. Oil sump - 3. Oil sump drain plug -
- 4. Lubrication oil filter - 5. Engine coolant return coupling -
- 6. Turbocharger - 7. Exhaust manifold

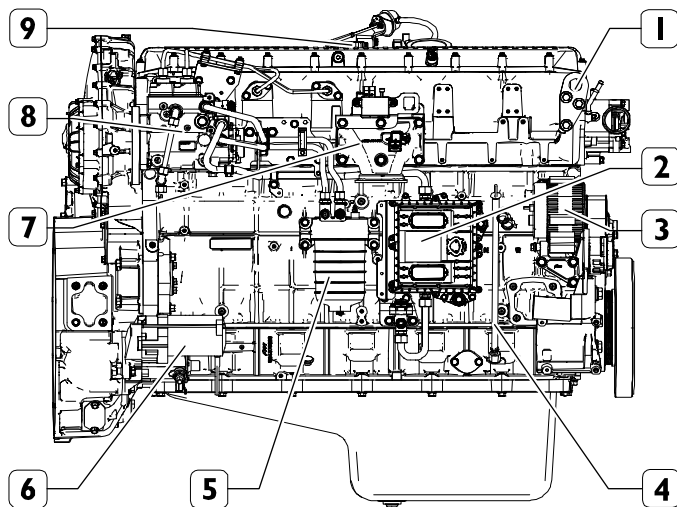

14_173_C

F3HFA615A*D001 - F3HFA615B*D001

- 1. Lifting eyelet - 2. Electronic control unit ECU - 3. Alternator -
- 4. Lubricant oil level dipstick - 5. Fuel filter - 6. Electric starter motor -
- 7. Intake manifold inlet - 8. High and low pressure pump for common rail system - 9. Engine oil filler cap

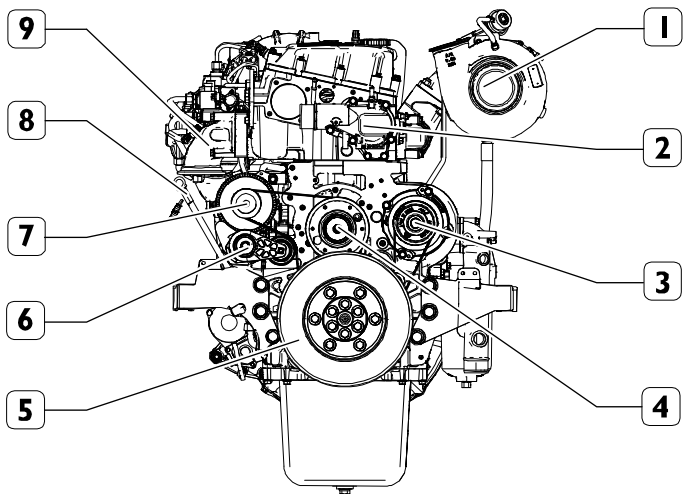

14_174_C

F3HFA615A*D001 - F3HFA615B*D001

1. Turbocharger - 2. Thermostat unit and cylinder head water outlet pipe - 3. Water pump - 4. Fan control coupling - 5. Crankshaft pulley - 6. Automatic tensioner - 7. Alternator - 8. Lubricant oil level dipstick - 9. Intake manifold inlet

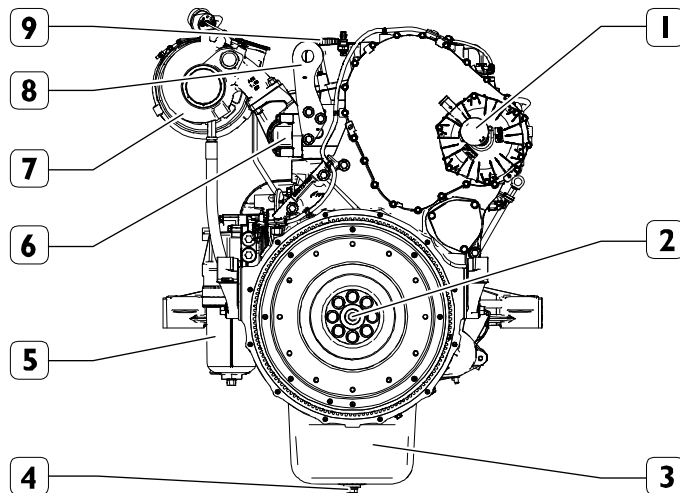

14_175_C

F3HFA615A*D001 - F3HFA615B*D001

1. Blow-by breather housing - 2. Engine flywheel - 3. Oil sump - 4. Oil sump drain plug - 5. Lubrication oil filter - 6. Exhaust manifold - 7. Turbocharger - 8. Lifting eyelet - 9. Engine oil filler cap

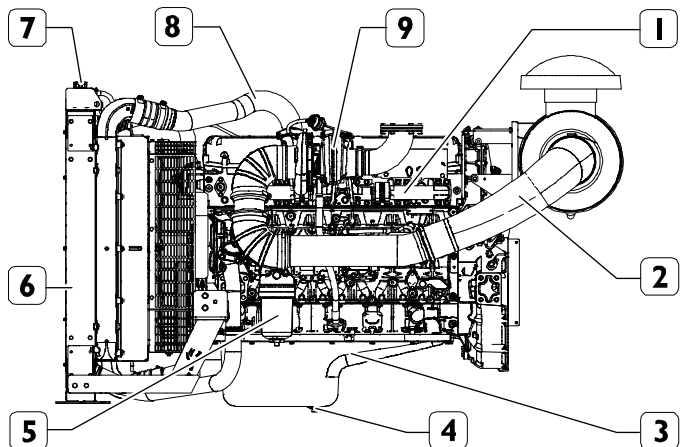

15_016_C

CR13 TE 6W - CR13 TE 7W

1. Exhaust manifold - 2. Air intake duct to turbocharger - 3. Oil sump - 4. Oil sump drain plug - 5. Lubrication oil filter - 6. Heat exchanger external air / coolant - 7. Coolant inlet plug - 8. Air intake duct to aftercooler

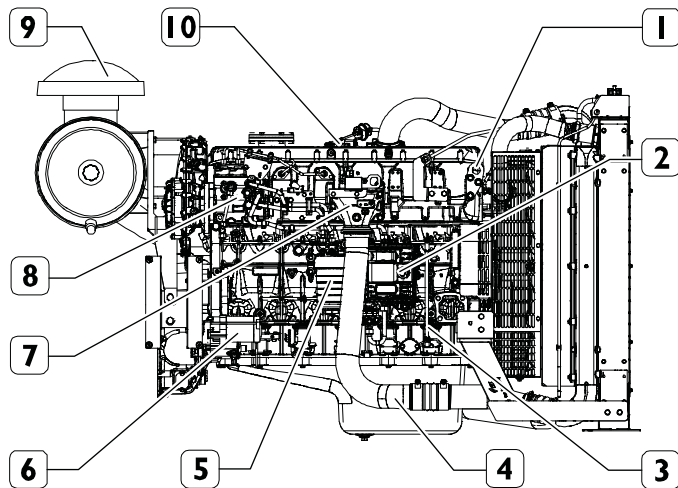

15_017_C

CR13 TE 6W - CR13 TE 7W

1. Lifting eyelet - 2. Electronic control unit ECU - 3. Lubricant oil level dipstick - 4. Air intake duct to engine - 5. Fuel filter - 6. Electric starter motor - 7. Intake manifold inlet - 8. High and low pressure pump for common rail system - 9. External air socket - 10. Engine oil filler cap

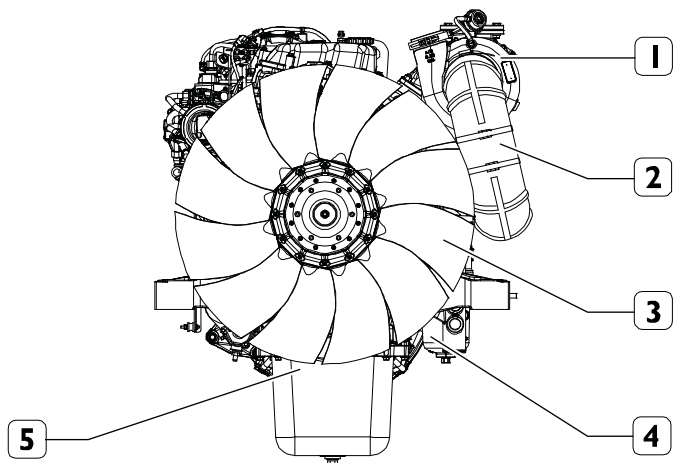

15_018_C

CR13 TE 6W - CR13 TE 7W

1. Turbocharger - 2. Air intake duct to turbocharger - 3. Fan - 4. Lubrication oil filter - 5. Oil sump

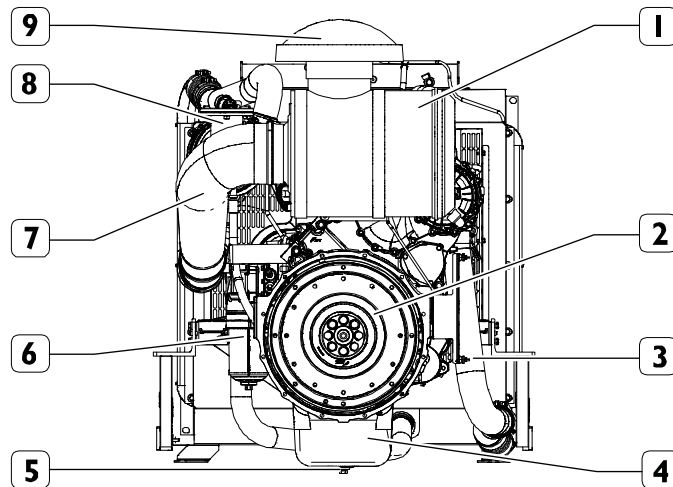

15_019_C

CR13 TE 6W - CR13 TE 7W

1. Air filter - 2. Engine flywheel - 3. Air intake duct to engine - 4. Oil sump - 5. Oil sump drain plug - 6. Lubrication oil filter - 7. Air intake duct to turbocharger - 8. Turbocharger - 9. External air socket

LABELS

Some warning labels (below the description) are affixed to the engine.

NOTE : labels containing an exclamation mark highlight a potential danger.



Lifting point (only the engine).



Fuel filling cap
(on the tank, if present).



Lubricant oil filling cap.



Lubricant oil level dipstick.



Risk of burns:
Expulsion of pressurized hot water.



Risk of burns:
Presence of parts at high temperature.



Risk of fire:
Presence of fuel.

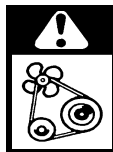

Risk of injury
from moving parts:
Presence of fans, pulleys, belts or other.

■ USE

PRELIMINARY CHECKS

Each time before starting the engine:

- Check and top up the level of the technical fluids, if necessary (fuel, engine oil and coolant).
- Make sure that the air intake filter is not obstructed or clogged.
- Make sure that the batteries are efficient and that the terminals are correctly connected.

ATTENTION!



Make sure that the environment where the engine will operate is free of combustible vapours or gases. Make sure that there is sufficient ventilation and a suitable exhaust gas extraction system for closed environments.

STARTING AND STOPPING THE ENGINE

The methods for starting and stopping will vary if the equipment or genset Manufacturer has created a customised dashboard; these methods vary based on the different choices of the Manufacturer.

In these cases, refer to what is indicated in the specific documentation for information regarding the start and stop sequences and the interpretation of the indicator instruments.

Starting the engine

1. Insert the key in the ignition switch and turn it clockwise to the "Run" position. After the test phase of the light signals and the acoustic alarm has stopped, check that the instruments provide indications that are plausible with the values of the physical temperature, battery voltage and oil pressure parameters.
2. Turn the key to the "Start" position, releasing it when the engine has started, without accelerating.
3. Check that the "Alternator recharge" and "Low oil pressure" indicators are off and the instruments provide indications that are plausible with the new values of the relative physical parameters.
4. If it does not start, it is possible to return to the start condition after releasing the key only after turning the switch to the rest position.

Stop engine

Before stopping the engine, it is recommended to keep it idling for a few minutes without a load; this will permit a uniform reduction in temperature and prevent harmful thermal shocks.

The stop methods depend on the type of equipment.

With the stop circuit “de-excited”

- Turn the key switch to the REST position

With the stop circuit “excited”

- Turn the key switch to the **STOP position**

Follow the instructions provided by the genset Manufacturer.

To restart the engine:

1. Return the key switch to the rest position, which resets all the functions performed by the instrument panel (required for electronic control engines).
2. Turn the key to the “Start” position, releasing it when the engine has started, without accelerating.
3. Proceed as indicated previously.

SPECIAL WARNINGS

High coolant temperature

In the event of an excessive temperature being signalled by the instrument or the alarm, reduce the engine speed and stop it in order to check the condition of the cooling circuit; also check and have the following checked:

- the tension of the water pump and alternator control belts;
- the operation of the thermostatic valve;
- the cleanliness of the heat exchangers.

ATTENTION



When the engine is hot, pressure builds up in the cooling circuits which may eject hot liquid violently, resulting in a risk of burns. Open the filler cap of the coolant tank only if necessary and only when the engine is cold.

Low lubricant oil pressure

Should the pressure indicated by the instrument be considered insufficient or if the “low oil pressure” warning light comes on, stop the engine and check the oil level. Top up the oil if necessary (see section CHECKS AND MAINTENANCE).

If the fault persists, return to low speed, and contact a Service centre.

Presence of water in the fuel pre-filter

It is advisable to drain the water from the filters before the relevant warning light comes on.

Do not use the engine if the tank only contains the quantity of fuel kept as reserve; this condition promotes the formation of condensate and the intake of sludge or air, causing the engine to stop.

ATTENTION



Pay maximum attention when refuelling, making sure that solid or liquid pollutants do not enter the tank; please remember that smoking is prohibited while refuelling.

Clogged air filter and exhaust circuit inefficiencies

Regularly inspect the cleanliness of the air intake inlets and the exhaust ducts. The maintenance intervals contained in this manual only take into account the performances of the engine parts and not of those parts manufactured at the Yard or any other external intervention.

ATTENTION



Visually check that the exhaust circuit is not obstructed or damaged to prevent the formation of noxious and harmful fumes inside the ducts.

Battery or alternator charging fault

Periodically check the cleanliness, condition and correct tensioning of the drive belt.



The drive belt members are located under protective grilles. Their removal must be carried out only when the engine is not turning.

Electrical system irregularities

Periodically check the cleanliness and efficiency of the batteries, particularly during winter, by performing the checks and top-ups as described in the CHECKS AND MAINTENANCE chapter; close attention must be paid to the caution notices. In the event of battery replacement, please observe the characteristics contained in the ENGINE TECHNICAL DATA section.



If the voltmeter indicates a voltage value lower than 22 V, contact a specialised workshop and have the efficiency of the batteries and charging system diagnosed.



RUN-IN

Thanks to modern engine construction technologies a particular run-in procedure is not required. However, it is recommended to avoid using the engine at high power for long periods during the first 50 hours.

■ CHECKS AND MAINTENANCE

MAINTENANCE PERSONNEL

The engine check and maintenance operations specified in this chapter require preparation, skill and compliance with safety standards; therefore, they must be carried out by responsible personnel, as indicated below.

- ❑ **Checks:** by workshop personnel or if necessary by the genset operator.
- ❑ **Periodic maintenance:** by qualified personnel equipped with proper work tools and suitable protections. 
- ❑ **Unscheduled maintenance:** by qualified Service Centre personnel in possession of precise technical information and specific equipment. 

The most qualified Service Centres are those included in the FPT Technical Service Network.

ACCIDENT PREVENTION

- ❑ Always wear safety footwear gloves and suits.
- ❑ Do not wear loose clothing, rings, bracelets and/or necklaces near the engines or moving parts.
- ❑ Wear protective gloves and goggles while:
 - filling the batteries with acid solution
 - refuelling with inhibitors or antifreeze
 - changing or filling the lubricant oil (hot engine oil can cause burns. It is recommended to perform these operations only when their temperature is lower than 50 °C).

- ❑ When working in the engine compartment, pay maximum attention to all movements to avoid coming into contact with rotating or hot components.
- ❑ Wear goggles while using compressed air (the maximum air pressure used for cleaning is 200 kPa (2 bar, 30 psi, 2 kg/cm²).
- ❑ Wear a protective helmet if working in an area with suspended loads or overhead systems.
- ❑ Use protective creams for hands.
- ❑ Immediately replace wet gloves.
- ❑ Always keep the engine clean, removing spots of oil, diesel and coolant.
- ❑ Return oily rags to fire-proof containers.
- ❑ Do not leave foreign objects on the engine.
- ❑ Use adequate and safe containers for the used oil.
- ❑ At the end of a repair, implement suitable measures to stop air intake by the engine if, after starting, the engine runs at uncontrolled speeds.



Do not perform maintenance in the case of live electrical voltage: check the condition of the equipment's ground connection. During the diagnostics and maintenance operations, make sure your hands and feet are dry and use insulating footboards if possible.

REFILLING

Parts to be refilled		CR13 TE 7 W CR13 TE 6 W litres (kg)
	Engine:	19.5
Cooling circuit ⁽¹⁾	G-Drive (Engine with Radiator and hoses):	38.1
Lubrication circuit ⁽²⁾ total capacity		32 (28.8) ⁽³⁾ 34 (30.6) ⁽⁴⁾
Periodic replacement: Sump at minimum level Sump at maximum level		20 (18) 28 (25)
Fuel tank ⁽⁵⁾		-

(1) The quantities indicated only refer to the engine in its standard configuration. Use a mixture of 50% water and PARAFLU 11/PARAFLU HT also during summer. As an alternative to PARAFLU 11/PARAFLU HT, use another product that complies with the specifications FPI9.COOL001, FPI9 or SAE J1034.

(2) Only use lubricants which comply with the international specifications 15W-40 ACEA E7 / API CI-4; 5W-30 ACEA E4 (with benefits in terms of fuel savings). FPT recommends the use of lubricant URANIA LD 7 15W-40 / URANIA FE 5W-30.

Oil consumption is considered acceptable up to quantities of 0.5% of fuel consumption.

(3) The quantity indicated only refers to the sump without the filter in standard configuration.

(4) The quantity indicated refers to the first refuelling and concerns the engine, oil sump and filter.

(5) Use STANDARD fuel which complies with standards ASTM D975 or EN 590. The indications relating to the fuel tank capacity apply to the machinery Manufacturer since they are subject to variations depending on the different configurations.

WARNING

Refuelling from drums or tanks can cause contamination of the diesel, with the consequent risk of damaging the injection system; if necessary, perform suitable filtration or sedimentation of the impurities before refuelling.

Diesel oil for low temperatures

Standard EN590 defines different diesel classes, identifying the characteristics of those most suitable for use at low ambient temperatures.

It is entirely the responsibility of the oil companies to comply with the regulations regarding the distribution of fuels suitable for the climatic and geographical conditions of the various countries.

FREQUENCIES

The frequencies indicated below take into account factors of use of different engine uses; the most suitable duration of the maintenance intervals for the different applications will be indicated by the maintenance personnel based on the use and operating conditions of the engine.

Checks in periods of use	Frequency**
Engine lubricant oil level check	daily
Engine coolant level check	daily
Engine visual inspection	50 hours/ 15 days
Air filter & housiness cleanness check	1 month
Tension and condition check of auxiliary members'belt	300hours/ 6 months
Exhaust duct(s) condition check	6 months

Planned maintenance	Frequency**
Water drainage from the fuel pre-filter (if present)	150 hours/ 6 months ⁽¹⁾
Condensed water drainage from the fuel tank (*)	150 hours/ 6 months
Engine lubricant oil replacement	600 hours/ 1 year ⁽²⁾
Lubricant oil filter replacement	600 hours/ 1 year ⁽²⁾⁽³⁾

Planned maintenance	Frequency**
Fuel pre-filter replacement (if present)	600 hours/ 1 year
Fuel filter replacement	600 hours/ 1 year ⁽¹⁾⁽³⁾⁽²⁾
Air filter replacement	1200 hours/ 2 years ⁽²⁾
Auxiliary members' belt replacement	1200 hours/ 3 years
Blow-by filter replacement	1800 hours/ 1 year

 Extraordinary maintenance	Frequency**
Turbocharger visual inspection	1200 hours / 2 years
Heat exchanger (radiator) cleaning	1200 hours / 2 years
Valves/rocker arms clearance adjustment	2400 hours
Engine coolant replacement	3000 hours / 2 years ⁽²⁾

* Components not supplied by FPT

** Intervention @ frequencies expressed by hours & temporal (whichever occurs first)

1) Maximum period relating to the use of high quality fuel, (specification ASTM D975 or EN 590); which is reduced in the

event of fuel contamination and alarm signals caused by filter clogging and/or the presence of water in the pre-filter. The filter clogging signal indicates that the filter must be replaced. If the warning light of water present in the pre-filter does not go off after drainage, then the pre-filter must be replaced.

- 2) Frequencies are valid for operating fluids which comply with the international specifications as indicated in the REFILLING table.
- 3) Only use filters with the following specifications:
 - degree of filtering < 12 μm
 - filtering efficiency 99.5% ($\beta > 200$).



In the event in which fuel is used with a sulphur percentage greater than 0.5%, or oils are used which do not comply with the specifications in the REFILLING table, then the replacement frequencies of the oil, engine oil filter and oil vapour filter must be halved, or suitably adjusted, in accordance with the use and operating conditions of the engine; please consult the personnel in charge of maintenance operations for appropriate advice.



The operations described above require the use of specific tools which guarantee safe and effective results. It is recommended that such operations are carried out by qualified personnel of the FPT Technical Service Network.

REQUIREMENTS

- Do not disconnect the battery supply while the engine is running.
- Do not perform arc welding near the engine without first removing its electrical wiring.
- After all maintenance operations that require disconnection of the batteries, make sure the clamps have been securely reconnected on the poles.
- Do not use a battery charger to start the engine.
- Electrically disconnect the battery/ies from the network during charging.
- Do not paint the devices, components and electrical connectors of the engine equipment.
- Electrically disconnect the battery/batteries before performing any electrical work.
- Contact the Manufacturer before installing any electronic equipment.



Do not perform any operation that would change the calibration of the injection pump. It was adjusted during the engine test phase and based on its destination.

CHECKS (IN PERIODS OF USE) - HOW TO PROCEED

Engine lubricant oil level check

Only proceed when the engine is not turning and is at low temperature in order not to run the risk of burns; make sure the engine is level or in its normal operating position in order to obtain an accurate oil level reading.

- ❑ Use the oil level dipstick (1) to check that the lubricant oil level is between the "Min" and "Max" limits.
- ❑ If the level is insufficient, it is necessary to top up the oil by removing the cap and pouring lubricant oil through the hole (2).



For the top-up only use lubricant oil that complies with the international standards as indicated in the REFILLING table.



Clean the oil cap before performing the operation so as to minimize the risk of contaminating the system.

- ❑ Use the oil level dipstick (2) to check that the lubricant oil level does not exceed the "Max" limit on the dipstick.



Make sure that the dipstick is fully inserted and that the filler plug is tightened fully in the clockwise direction.

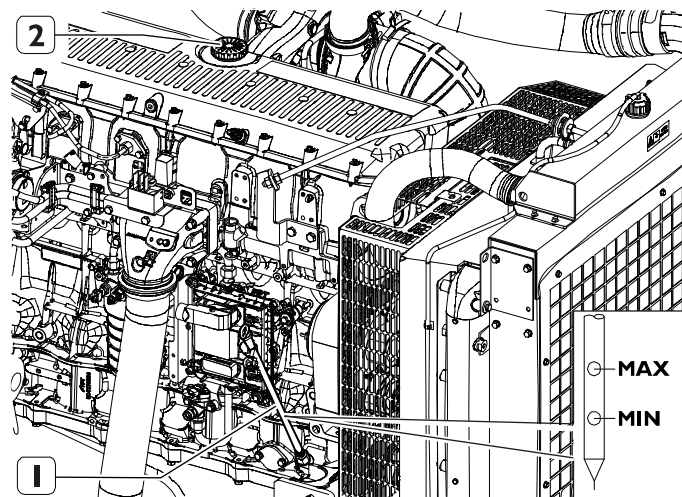

15_020_C

Engine coolant level check

Only proceed when the engine is not turning and is at low temperature in order not to run the risk of burns.

- ❑ Remove the pressurization cap from the expansion tank.
- ❑ Check that the coolant in the expansion tank is above the minimum level.
- ❑ If necessary, top up the expansion tank with a mixture of 50% water and PARAFLU 11/PARAFLU HT, as contained in the REFILLING table.
- ❑ Top up the expansion tank until the "MAX" limit is reached; if there is no level indicator on the expansion tank, make sure that the coolant in the expansion tank is a few centimetres below the filling hole in order to allow an increase in the coolant volume following a rise in temperature.



When the engine is hot, pressure builds up in the cooling circuits which may eject hot liquid violently, resulting in a risk of burns.

Open the filler cap of the coolant tank only if necessary and only when the engine is cold.



Clean the pressurization cap of the expansion tank before performing the operation so as to minimize the risk of contaminating the system.

Engine visual inspection

Perform a thorough check before start-up in order to obtain maximum engine duration.

Check for any leaks (oil, coolant and fuel), broken or weakened pipes, loose clips and bolts, worn belt, wiring (loose connections, worn or frayed cables) and a build-up of dirt; in the event of any problems, perform the operations necessary to restore the engine.



Any spilt fluid must be removed for all types of leak (coolant, oil or fuel).

If a leak is discovered then find its source and carry out the necessary repair.



A build-up of oil or grease on the engine represents a fire risk.

Air filter & housing cleanness check

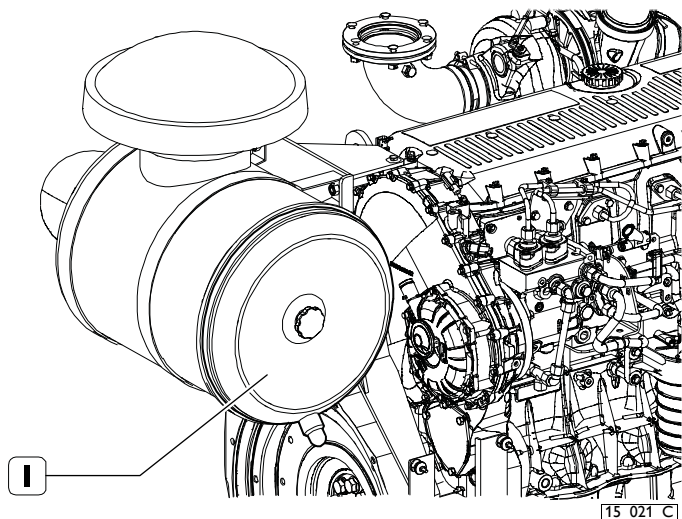

Only proceed with the engine switched off.

Remove the cover (1).

Remove the filter cartridge.

Make sure there are no impurities. Otherwise, clean the filter element according to the instructions provided below.

Blow dehumidified compressed air on the filter element, working from the inside outwards (maximum pressure 200 kPa).

Do not use detergents; do not use diesel.

Never strike the filter element with tools and check its condition before refitting.

Replace it if broken or torn.

Check the condition of the gasket at its base.

Proceed with assembly by reversing the sequence used for disassembly.



Make sure to assemble the parts correctly. Imperfect assembly could make it possible for the engine to intake unfiltered air, which would cause serious damage to the engine.

Tension and condition check of auxiliary members' belt

Only proceed when the engine is not turning and is at low temperature so as not to run the risk of burns.

- Unscrew the screws (1) and remove the fan protection grille (2).
- Check that the belt is not worn, soiled with oil or fuel, or showing signs of tears. Otherwise replace the belt if necessary .
- Use a ½ inch square wrench to check the efficiency of the automatic belt tensioner.



When the engine is off, but still hot, the belt may start to move without warning. Wait for the engine temperature to decrease to prevent serious danger of an accident.

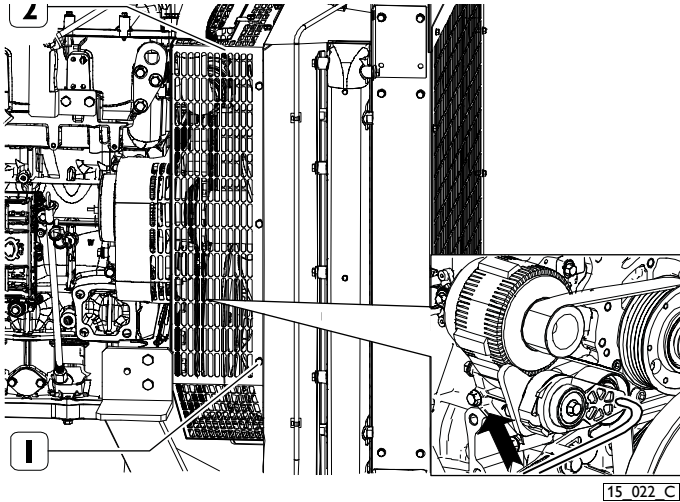

Exhaust duct(s) condition check

Visually check that the exhaust gas system is not blocked, corroded or damaged.
in the event of any problems, perform the operations necessary to restore the exhaust duct.

PLANNED MAINTENANCE - HOW TO PROCEED

Water drainage from the fuel pre-filter (if present)

In the case of a high risk of refuelling with fuel polluted with foreign agents and water, the following check should be performed at each refuelling.

Proceed when the engine is not turning.

- ❑ Place a container for collecting liquids under the pre-filter (2).
- ❑ Unscrew the valve plug (1) located at the bottom of the filter; in some versions, the plug includes the water in diesel sensor.
- ❑ Drain the liquid until only "diesel" is released.
- ❑ Fully retighten the plug manually.
- ❑ Dispose of the drained liquids according to the applicable regulations in force.

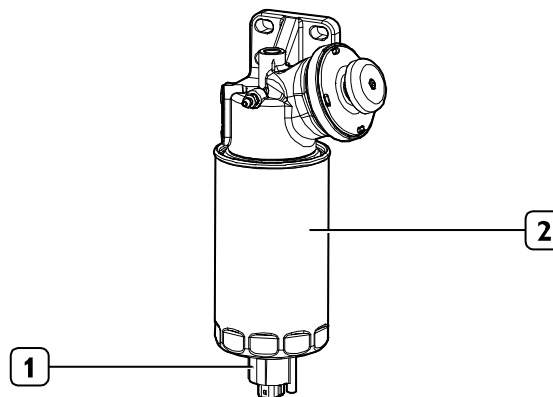

14_122_C

Condensed water drainage from the fuel tank

Perform the drainage/suction of water, condensation and impurities from the fuel tank/s by following the instructions contained in the manual supplied by the tank manufacturer.

Proceed as necessary based on the structure or location of the tank: engines that operate in adverse environments and conditions and/or that are refuelled using drums or jerry cans, require more attention when cleaning the tank.



Clean the cock tap (1) before performing the operation so as to minimize the risk of contaminating the system.

Engine lubricant oil replacement

Only proceed when the engine is not turning and is at low temperature so as not to run the risk of burns.

- ❑ Place a suitable container for collecting the spent oil under the oil sump next to the lubricant oil drain plug (3).
- ❑ Unscrew the lubricant oil drain plug (3); afterwards extract the oil level dipstick (1) and remove the lubricant oil cap (2) to assist the flow of the engine lubricant oil.
- ❑ Wait until the oil sump has completely emptied, then retighten the lubricant oil drain plug (3) to the torque indicated in the table
- ❑ Proceed with the refilling operation through the hole (2) situated on the tappet cover, using lubricant oil that complies with the international standards as indicated in the REFILLING table.
- ❑ Use the oil level dipstick (1) to check that the quantity of lubricant oil does not exceed the "Max" limit.
- ❑ Retighten the lubricant oil cap (2).
- ❑ Together with the replacement of the engine lubricant oil it is necessary to replace the oil filter (see paragraph ENGINE OIL FILTER REPLACEMENT).

Ref.	No.	Description	Torque
3	1	Oil drain plug	40 ± 10 Nm



After changing the engine lubricant oil make sure that the level does not exceed the "Max" limit on the oil level dipstick.



Make sure that the dipstick is fully inserted and that the filler plug is tightened fully in the clockwise direction.



Dispose of consumable materials and parts in contact with them (e.g. filters) in accordance with the law.



Clean the plugs before performing the operations so as to minimize the risk of contaminating the system.

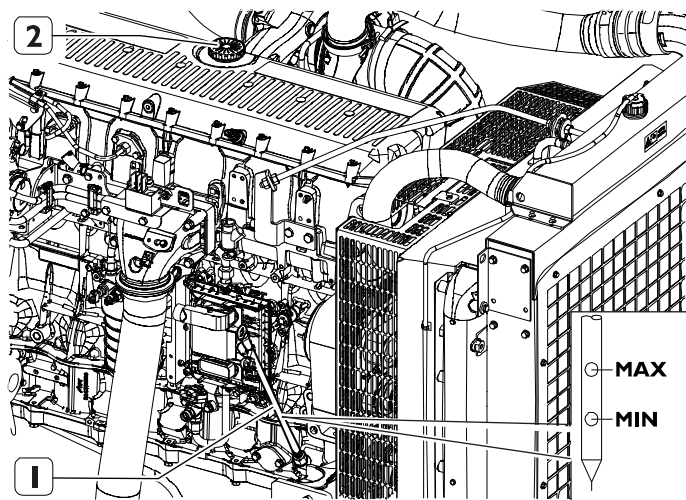

15_020 C

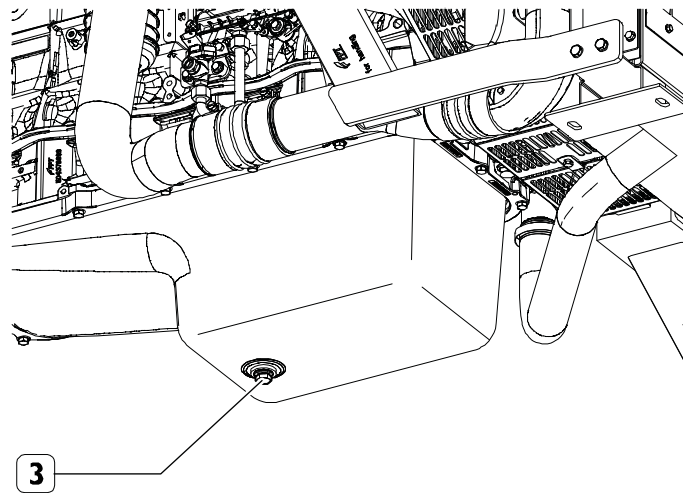

15_023 C

Lubricant oil filter replacement

Only use filters with the following specifications:

- degree of filtering $< 12 \mu\text{m}$
- filtering efficiency $\beta > 200$ (99.5%)

Only proceed when the engine is not turning and is at low temperature so as not to run the risk of burns.

- Proceed with draining the spent lubricant oil (see paragraph ENGINE LUBRICANT OIL REPLACEMENT).
- Place a suitable container for collecting the spent oil under the oil filter next to the drain plug (3).
- Remove the filter (4) by unscrewing it.
- Replace the filter element (2) and the O-ring seal (1) contained inside the filter (4).
- Carefully clean the surfaces
- Moisten the O-ring seal (1) of the new filter with oil.
- Tighten the drain plug (3) and the filter body (4) to the torque indicated in the table.
- Proceed with the refilling operation of the lubricant oil (see paragraph ENGINE LUBRICANT OIL REPLACEMENT).

Operate the engine for a few minutes and then check the level using the dipstick.

If necessary, top up to compensate for the quantity of oil used to fill up the filtering cartridge.

Ref.	No.	Description	Torque
1	1	Engine oil filters	$60 \pm 5 \text{ Nm}$
3	1	Drain plug on engine oil filter	$6.5 \pm 1.5 \text{ Nm}$



After changing the engine lubricant oil make sure that the level does not exceed the "Max" limit on the oil level dipstick.



Make sure that the dipstick is fully inserted and that the filler plug is tightened fully in the clockwise direction.



Dispose of consumable materials and parts in contact with them (e.g. filters) in accordance with the law.

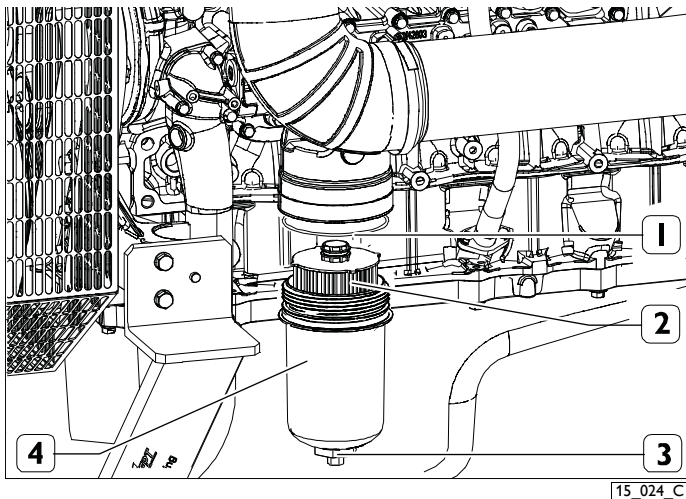

15 024 C

Fuel pre-filter replacement (if present)

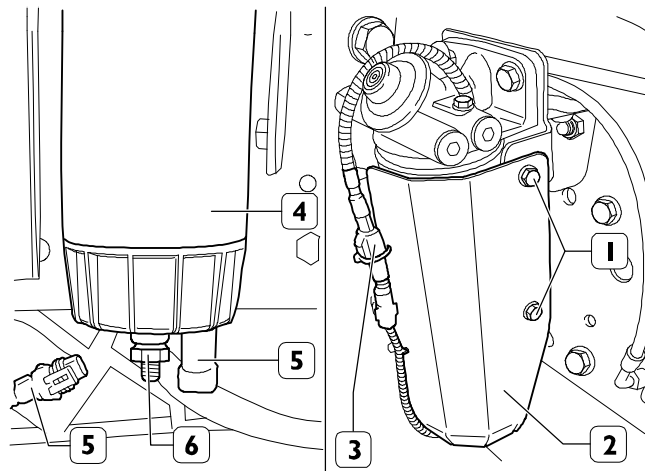

15 039 C

Disengage the connection (3).

Unscrew the screws (1) and remove the protective panel (2) (if present).

Disconnect the connection cable (5); place a container, open the cap (6) and drain the fuel present in the filter.

Unscrew the filter (4) and replace it.

Before replacing the new cartridge moisten the gasket with fuel or engine oil.

Screw in the cartridge until it touches the surface and tighten it to the specified torque.

Close the fuel drain plug, connect the electrical connection, replace the protective panel and engage the connection cable on the panel.



*The filter cartridge does not have to be pre-filled.
This is to prevent the entry into the circulation of any impurities that could damage fuel system components
Bleed air from the fuel circuit.*

Fuel filter replacement

Only proceed when the engine is not turning and is at low temperature so as not to run the risk of burns.

- Close the tank cock.
- Place a suitable container for collecting the fuel under the fuel filter next to the drain plug (4).
- Open the drain plug (4) and the bleeder connection (1) and drain any residual fuel.
- Remove the filter element (3) by unscrewing the relative bell-shaped support (5).
- Replace the filter element (3) and the O-ring seal (2) contained inside the bell-shaped support (5).
- Moisten the O-ring seal (2) of the filter with oil.
- Insert the filter element (3) and tighten the relative bell-shaped support (5) to the torque indicated in the table.
- Tighten the drain plug (4) to the torque indicated in the table.



Do not fill the new filter until it has been positioned on the support: this prevents allowing impurities to enter and damage the circuit and injection system.

Ref.	No.	Description	Torque
3	1	Fuel filter	32.5 ±2.5 Nm
4	1	Threaded plug	1.5 ±0.5 Nm
5	1	Bleeder connection	17.5 ±2.5 Nm

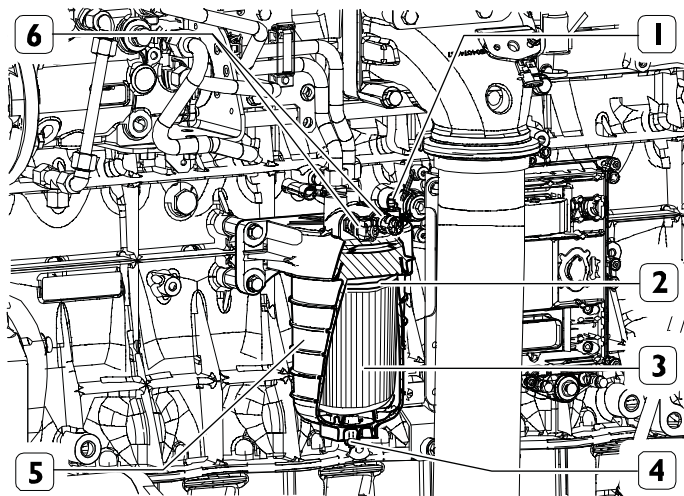

15 025 C

- Loosen the following bleeder connections and connect them with appropriate pipes to allow any residue to drain into suitable containers so as to prevent soiling:

- Screw (1) situated on the pre-filter support (if present).
- Bleeder connection (3) situated on the filter support.

- Operate the pump (2) situated on the fuel pre-filter (if present) until fuel flows out without air from the bleeder screw (1); upon completion of the operation tighten the screw.
- Continue to operate the pump until fuel flows out without air from the bleeder connection (3) situated on the fuel filter; upon completion of the operation tighten the screw.



Take utmost care to prevent any fuel from soiling the control belt

- Tighten the bleeder screws to the prescribed torque.

Ref.	No.	Description	Torque
1	1	Pre-filter bleeder screw	18 ±2 Nm
3	1	Bleeder connection	17.5 ±2.5 Nm

- Start the engine and allow it to idle for a few minutes to expel any residual air from the circuit.



For the engine to function correctly the fuel circuit must be free from air.



Dispose of consumable materials and parts in contact with them (e.g. filters) in accordance with the law.

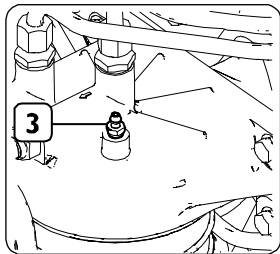

3

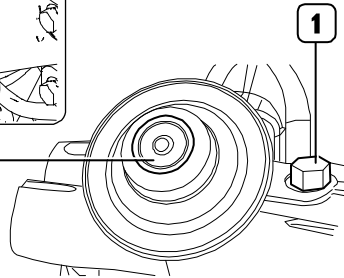

1

14_126 C

Air filter replacement

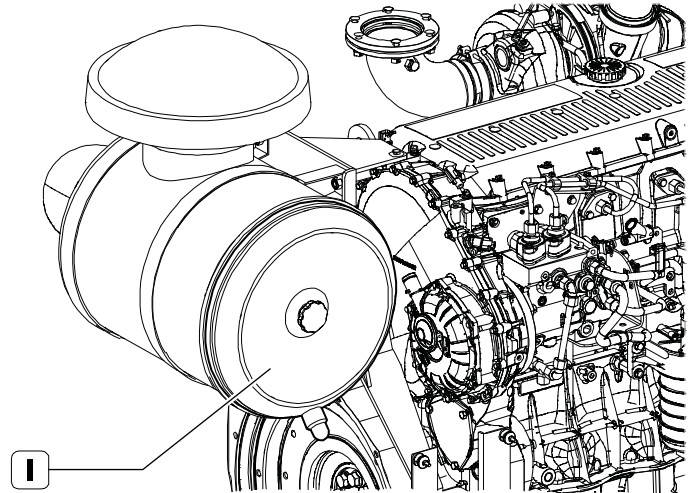

15_021 C

Only proceed with the engine switched off.

Remove the cover (1).

Remove the filter cartridge.

Make sure there are no impurities. Otherwise, clean the filter housing accurately.

Fit a new filter cartridge.

Fit the cover and fasten the relative clips.



Make sure to assemble the parts correctly. Imperfect assembly could make it possible for the engine to intake unfiltered air, which would cause serious damage to the engine.



When the engine is off, but still hot, the belt may start to move without warning. Wait for the engine temperature to decrease to prevent serious danger of an accident.

Auxiliary members' belt replacement

Only proceed when the engine is not turning and is at low temperature so as not to run the risk of burns.

- Remove the protective grilles, the radiator assembly and the fan.
- Using a 1/2 inch square wrench, operate on the belt tensioner (2) and pull off the control belt of the crankshaft pulley / electromagnetic coupling / water pump / alternator (1).
- Replace the worn belt with a new one and fit it on the pulleys and guide rollers.
- Using the aforesaid tools, operate on the automatic belt tensioner in order to force fit the new belts in their operating position.



Replace the belt if it shows signs of abrasion, cracks or tears or if it is soiled with oil or fuel.

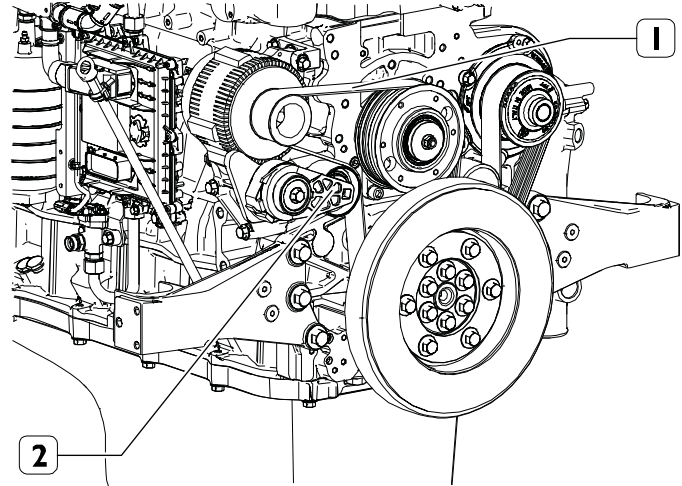

14 180 C

Blow-by filter replacement

- ❑ Unscrew the screws (3) and remove the cover (4)
- ❑ Unscrew the screws (2) and remove the blow-by filter element (1)



Carefully clean the filter seat and the cover.

- ❑ Position the new blow-by filter element (1) in its seat.
- ❑ Apply some Loctite 243 on the screws (2) and tighten them to the torque indicated in the table.
- ❑ Position the cover (4) and tighten the screws (3) to the torque indicated in the table.

Ref.	No.	Description	Torque
2	3	Fastening screws for blow-by filter element M6x1,0x40	Pre-tightening 5 Nm Tightening 15 ±1.5 Nm
3	6	Fastening screws for blow-by cover M6x1,0x25	10 ±1 Nm



Dispose of consumable materials and parts in contact with them (e.g. filters) in accordance with the law.

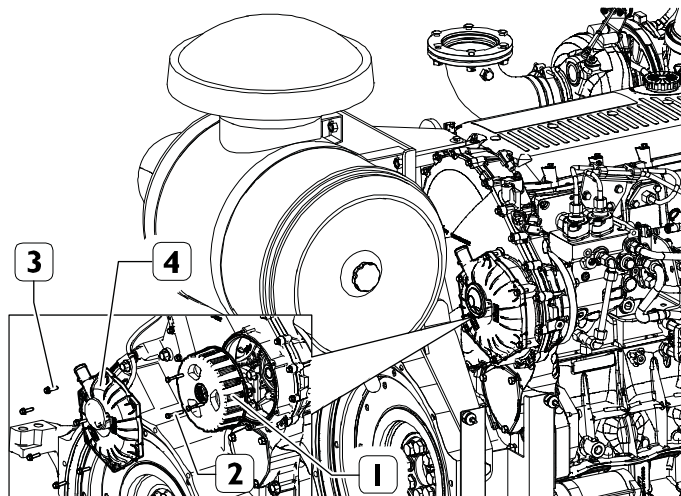

15_037 C

EXTRAORDINARY MAINTENANCE - HOW TO PROCEED

Turbocharger visual inspection

Only proceed when the engine is not turning over. Visually check that the turbine and compressor impellers and the relative inlet and outlet pipes are not obstructed or damaged, otherwise replace them.

Heat exchanger (radiator) cleaning

The surfaces of the heat exchanger (radiator) come into contact with external air and may be subjected to deposits and impurities (dust, mud, straw, etc.).

Clean them if necessary using compressed air or steam.

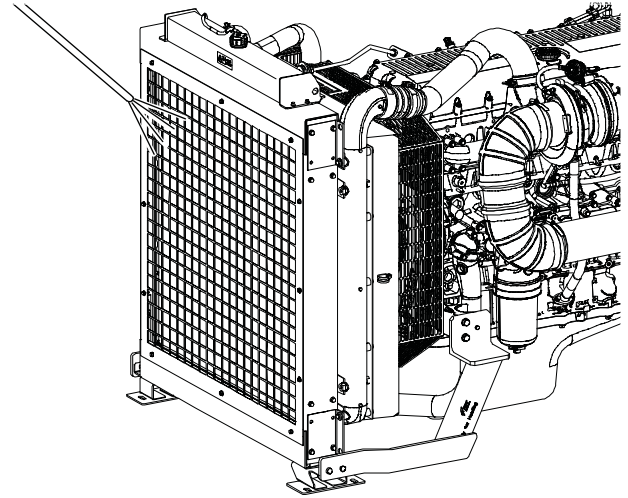

15_038_C

ATTENTION!



When using compressed air, it is required to use suitable personal protections for hands, face and eyes. The requirements can be found in the ACCIDENT PREVENTION paragraph.

Valves/rocker arms clearance adjustment

Adjustment of the play between the rocker arms and the intake and exhaust valve control rods must be performed with great care.

Put the cylinder requiring play adjustment into ignition phase; the valves of this cylinder will be closed while those of the symmetrical cylinder are balanced. The symmetrical cylinders are 1-6, 4-3 and 2-5. In order to correctly perform these operations proceed as described in the relative Repair Manual.

Engine coolant replacement

- ❑ Only proceed when the engine is not turning and is at low temperature so as not to run the risk of burns.
- ❑ Place a container for collecting coolant under the heat exchanger (radiator) (3).
- ❑ Remove the pressurization cap from the expansion tank.
- ❑ Loosen the fastening elements and remove the coupling sleeves (1 and 2) connecting the engine cooling circuit to the heat exchanger.
- ❑ Drain the coolant from the heat exchanger (radiator) (3) and wait until it is completely empty.
- ❑ Once emptied, restore the integrity of the cooling circuit, by ensuring the perfect seal of the sleeves.
- ❑ Refill the engine and the heat exchanger until the cooling circuit has been completely refilled using a mixture of 50% water and PARAFLU 11/PARAFLU HT, as contained in the REFILLING table. Do not fill the expansion tank to the brim.
- ❑ With the coolant filler plug (4) open, start the engine and let it idle for approx. one minute. This helps to completely bleed the air contained in the cooling circuit.
- ❑ Stop the engine and then top up with coolant if necessary.
- ❑ When the engine is cold, make sure that the coolant in the expansion tank is a few centimetres below the filling hole.
- ❑ If there is an external level indicator on the heat exchangers, proceed with the top-up making sure that the coolant does not completely fill the exchanger in order to allow an increase in the coolant volume following a rise in temperature.

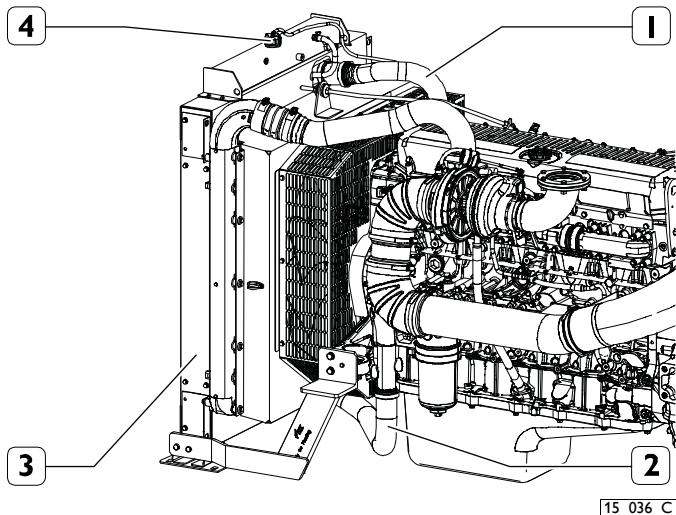

When the engine is hot, pressure builds up in the cooling circuits which may eject hot liquid violently, resulting in a risk of burns. Open the filler cap of the coolant tank only if necessary and only when the engine is cold.



Failure to observe the procedure described above does not guarantee the presence of the correct quantity of coolant in the engine

ENGINE HANDLING

The engine must only be disconnected and reconnected by Service Centre personnel.

To lift only the engine use the eyelets specified in this manual in the ENGINE TECHNICAL DATA *section* and marked on the engine with specific plates.

It must be hoisted using a rocker arm that keeps the metal ropes that support the engine parallel, using all the provided eyelets at the same time; it is not permitted to use only one eyelet.

The capacity and dimensions of the engine hoisting system must be suitable for the engine weight and dimensions; make sure there is no interference between the hoisting system and the engine components. Do not hoist the engine before removing the transmission components coupled to it.

DISPOSAL OF WASTE

The engine consists of parts and elements that can cause ecological damage if disposed of in the environment.

The materials listed below must be delivered to authorised collection Centres; The laws in force in the different countries foresee severe penalties for violators:

- Starter batteries.
- Spent lubricant oils.
- Water and antifreeze mixtures.
- Filters.
- Auxiliary cleaning material (e.g. rags soaked in or moistened with fuel).

■ LONG PERIOD OF ENGINE INACTIVITY

PREPARING THE ENGINE FOR A LONG PERIOD OF INACTIVITY

In the case of a planned period of inactivity that lasts longer than two months, to prevent the interior parts of the engine and some components of the injection system from oxidising, prepare the engine as follows:

1. Drain the lubricant oil from the sump after heating the engine.
2. Pour protective oil type 30/M into the engine up to the "minimum" level indicated on the oil level dipstick. Start the engine and run it for approx. 5 minutes.
3. Drain the fuel from the injection circuit, from the filter and from the injection pump channels.
4. Connect the fuel circuit to a tank containing CFB protective liquid (ISO 4113) and introduce the liquid by pressurising the circuit and driving the engine for approx. 2 minutes, after excluding the operation of the injection system. The required operation may be completed by directly polarising terminal 50 of the electric starter motor with positive voltage equal to that of the nominal system voltage, using the specifically provided conductor.
5. Nebulize the protective oil 30/M in a quantity of approx. -- g (10 g per litre of displacement) in the turbocharger intake inlet, during the engine turning operation described in the previous paragraph.
6. Close all of the engine's intake, discharge, ventilation and bleeder holes with plugs or seal them with adhesive tape.

7. Drain the residual 30/M protective oil from the sump, which can be used for an additional 2 preparations.
8. Place warning notices of ENGINE WITHOUT OIL on the engine and dashboard.
9. Drain the coolant if it was not mixed if necessary with antifreeze and corrosion inhibitors, positioning signs that this operation was performed.

In the case of prolonged inactivity, repeat these operations every 6 months, according to the following procedure:

- A) drain the 30/M protective oil from the sump;
- B) repeat the operations from point 2 to point 7.

To protect the external parts of the engine, spray the OVER 19 AR protective liquid on the unpainted metal parts such as the flywheel, pulleys, etc., and do not spray it on belts, connector cables and electrical equipment.

ENGINE START-UP AFTER A LONG PERIOD OF INACTIVITY

1. Drain the residual 30/M protective oil from the sump.
2. Add the type and quantity of lubricant oil to the engine as specified in the REFILLING table.
3. Drain the protective fluid CFB from the fuel circuit bringing to a close the operations as indicated in point 3 of the PREPARATION OF THE ENGINE FOR A LONG PERIOD OF INACTIVITY.
4. Remove the plugs and/or seals from the engine's intake, discharge, ventilation and bleeder holes, restoring normal conditions of use. Connect the turbocharger intake inlet to the air filter.
5. Join the fuel circuits to the machine's tank bringing to a close the operations as indicated in point 4 of the PREPARATION OF THE ENGINE FOR A LONG PERIOD OF INACTIVITY. During the filling operations, connect the tank fuel return pipe to a collection container to prevent the residual CFB protective liquid from flowing into the tank.
6. Check and fill the engine with coolant as required, degassing if necessary.
7. Start the engine and let it idle until completely stabilised.
8. Check that the indications on the dashboard are plausible and that there are no alarm signals.
9. Stop the engine.
10. Remove the warning notices of ENGINE WITHOUT OIL from the engine and dashboard.

■ ENGINE FAULTS

The Electronic Unit that manages and controls all engine operations is able to detect the occurrence of faults and adopt strategies to proceed in a safe manner.

The event, signalled by the switching on of the EDC Fault indicator on the dashboard involves the programmed limitation of power within the thresholds determined based on the severity of the situation.

In the case of brief anomalies, the performance will be reduced until the engine stops.

BEHAVIOUR IN THE CASE OF A FAULT

Recharging system fault

The electronic engine control units are programmed to increase the speed if the electrical system voltage reaches the values considered at the limit of efficiency. In that case, check the state of the battery or batteries and if necessary, have diagnostics performed for the system components.

ATTENTION!



Never abandon the equipment or cars with the engine operating without previously engaging the brake or parking lock.

ATTENTION!



The engine's electronic control unit may adopt the safety strategies while using the car or equipment at any moment conditions are verified that could place the engine's integrity at risk.

If these conditions occur, proceed only if necessary and in a cautious and attentive manner.