

Technical Data

4000 Series

4012-46TWG2A

Diesel Engine - Electropak

1500 rev/min

Basic technical data

Number of cylinders	12
Cylinder arrangement	Vee 60°
Cycle	4 stroke, compression ignition
Induction system	turbocharged
Combustion system.....	direct injection
Compression ratio	13:1 nominal
Bore.....	160 mm
Stroke	190 mm
Cubic capacity.....	45.842 litres
Direction of rotation	Anti clockwise viewed on flywheel
Firing order	1 ^A ,6 ^B ,5 ^A ,2 ^B ,3 ^A ,4 ^B ,6 ^A ,1 ^B ,2 ^A ,5 ^B ,4 ^A ,3 ^B
Cylinder 1	furthest from flywheel

Note: Cylinders designated 'A' are on the right hand side of the engine when viewed from the flywheel end.

Total weight of Electropak

Engine - dry	
-temperate	4440 kg
-tropical	4440 kg
Electropak - dry ⁽¹⁾	
-temperate	5220 kg
-tropical	5283 kg
Electropak - wet ^{(1) (2)}	
-temperate	5547 kg
-tropical	5615 kg

1. Includes fuel cooler.

2. Includes engine lubricating oil and water jacket

Overall dimensions of Electropak

Height	2255 mm
Length	3714 mm
Width	
-temperate	1780 mm
-tropical	1978 mm

Moment of inertia (mk²)

Flywheel	9,57 kgm ²
Engine.....	9,73 kgm ²

Cyclic irregularity

For engine/flywheel maximum:

-4012-46TWG2A @ 1500 rev/min.....	1-752
-4012-46TWG3A @ 1500 rev/min.....	1-752

Ratings

Steady state speed stability at constant load

± 0,25%

Electrical ratings are based on average alternator efficiency and are for guidance only (0.8 power factor being used).

Operating point

Engine speed	1500 rev/min
Static injection timing	spill timing 22°
Cooling water exit temperature	< 98 °C

Performance

Note: All data based on operation to ISO 3046/1, BS 5514 and DIN 6271 standard reference conditions.

Estimated sound pressure level at 1 metre

111 d(B)A

Note: Noise levels represent highest recorded at 1500 rev/min

For engines operating in ambient conditions other than the standard reference conditions stated below, a suitable de-rate must be applied.

De-rate tables for increased ambient temperatures and / or altitude are available, please contact Perkins Applications Department

Test conditions

-air temperature.....	25 °C
-barometric pressure	100 kPa
-relative humidity	30%
-air inlet restriction at maximum power (nominal).....	2,5 kPa
-exhaust back pressure at maximum power (nominal).....	3,0 kPa
-maximum fuel temperature (inlet pump)	58 °C

For test conditions relevant to data on load acceptance, please refer to Cold start recommendations on page 22 of this document.

General installation - 4012-46TWG2A (Temperate) 50 Hz @ 1500 rev/min

Designation	Units	Type of operation and application		
		Base	Prime	Standby
Gross engine power	kWb	884	1106	1217
Fan and battery charging alternator power	kW	51		
Net engine power	kWm	833	1055	1166
Brake mean effective pressure (gross)	kPa	1543	1930	21,24
Combustion air flow at ISO conditions	m³/min	90	102	109
Exhaust gas temperature (max) after turbo	°C	422		
Exhaust gas flow (max) at atmospheric pressure	m³/min	230		
Boost pressure ratio	-	2,38	2,86	3,09
Mechanical efficiency	%	88.0	90.2	91.0
Overall thermal efficiency (nett)	%	39.46	39.81	39.66
Friction and pumping power losses	kWm	120		
Mean piston speed	m/s	9,5		
Engine coolant flow	l/min	948		
Typical GenSet electrical output (0.8pf)	kVA	989	1253	1385
	kWe	791	1002	1108
Assumed alternator efficiency	%	95		

General installation - 4012-46TWG2A (Tropical) 50 Hz @ 1500 rev/min

Designation	Units	Type of operation and application		
		Base	Prime	Standby
Gross engine power	kWb	891	1113	1224
Fan and battery charging alternator power	kW	58		
Net engine power	kWm	833	1055	1166
Brake mean effective pressure (gross)	kPa	1555	1942	2136
Combustion air flow at ISO conditions	m³/min	90	103	109
Exhaust gas temperature (max) after turbo	°C	422		
Exhaust gas flow (max) at atmospheric pressure	m³/min	235		
Boost pressure ratio	-	2,39	2,87	3,10
Mechanical efficiency	%	88.1	90.3	91.1
Overall thermal efficiency (nett)	%	39,5	39,8	39,6
Friction and pumping power losses	kWm	120		
Mean piston speed	m/s	9,5		
Engine coolant flow	l/min	948		
Typical GenSet electrical output (0.8pf)	kVA	989	1253	1385
	kWe	791	1002	1108
Assumed alternator efficiency	%	95		

Notes:

- All quoted gross engine powers include an allowance of 1.5% for installation variance
- Not to be used for CHP design purposes (indicative figures only). Consult Perkins Engines Stafford Limited. Assumes complete combustion.

General installation - 4012-46TWG3A (Temperate), 50 Hz @ 1500 rev/min

Designation	Units	Type of operation and application		
		Base	Prime	Standby
Gross engine power	kWb	960	1200	1314
Fan and battery charging alternator power	kW	51		
Net engine power	kWm	909	1149	1263
Brake mean effective pressure (gross)	kPa	1675	2094	2293
Combustion air flow at ISO conditions	m ³ /min	94	108	114
Exhaust gas temperature (max) after turbo	°C	474		
Exhaust gas flow (max) at atmospheric pressure	m ³ /min	240		
Boost pressure ratio	-	2.55	3.05	3.28
Mechanical efficiency	%	88.9	90.9	91.6
Overall thermal efficiency (nett)	%	39.66	39.80	38.95
Friction and pumping power losses	kWm	120		
Mean piston speed	m/s	9,5		
Engine coolant flow	l/min	948		
Typical GenSet electrical output (0.8pf)	kVA	1079	1364	1500
	kWe	864	1092	1200
Assumed alternator efficiency	%	95		

General installation - 4012-46TWG3A (Tropical), 50 Hz @ 1500 rev/min

Designation	Units	Type of operation and application		
		Base	Prime	Standby
Gross engine power	kWb	967	1207	1321
Fan and battery charging alternator power	kW	58		
Net engine power	kWm	909	1149	1263
Brake mean effective pressure (gross)	kPa	1688	2106	2305
Combustion air flow at ISO conditions	m ³ /min	94	108	115
Exhaust gas temperature (max) after turbo	°C	479		
Exhaust gas flow (max) at atmospheric pressure	m ³ /min	245		
Boost pressure ratio	-	2.56	3.07	3.30
Mechanical efficiency	%	89.0	91.0	91.7
Overall thermal efficiency (nett)	%	39.67	39.75	38.92
Friction and pumping power losses	kWm	120		
Mean piston speed	m/s	9,5		
Engine coolant flow	l/min	948		
Typical GenSet electrical output (0.8pf)	kVA	1079	1364	1500
	kWe	864	1092	1200
Assumed alternator efficiency	%	95		

Notes:

- All quoted gross engine powers include an allowance of 1.5% for installation variance
- Not to be used for CHP design purposes (indicative figures only). Consult Perkins Engines Stafford Limited. Assumes complete combustion.

Rating definitions

Baseload power

Unlimited hours usage with an average load factor of 100% of the published baseload power rating.

Prime Power

Variable load. Unlimited hours usage with an average load factor of 80% of the published prime power rating over each 24 hr. period A 10% overload is available for 1 hour in every 12 hour of operation.

Standby power

Variable load. Limited to 500 hours annual usage up to 300 hours of which may be continuous running. No overload is permitted.

Emissions capability

All 4012-46TWG ratings are optimised to the 'best fuel consumption' and do not comply to Harmonised International Regulation Emission Limits. More information on these statements can be obtained by contacting the Applications Department at Perkins Engines Company Limited.

Energy balance

4012-46TWG2A - Temperate

Designation	Units	50 Hz @ 1500 rev/min		
		Baseload power	Prime power	Standby power
Energy in fuel	kWt	2107	2632	2939
Energy in power output (gross)	kWb	884	1106	1217
Energy to cooling fan	kWm	51		
Energy in power output (nett)	kWm	833	1055	1166
Energy to exhaust	kWt	684	878	1001
Energy to coolant and oil	kWt	345	372	401
Energy to radiation	kWt	64	81	89
Energy to charge cooler	kWt	131	195	232

4012-46TWG2A - Tropical

Designation	Units	50 Hz @ 1500 rev/min		
		Baseload power	Prime power	Standby power
Energy in fuel	kWt	2123	2650	2960
Energy in power output (gross)	kWb	891	1113	1224
Energy to cooling fan	kWm	58		
Energy in power output (nett)	kWm	833	1055	1166
Energy to exhaust	kWt	689	886	1009
Energy to coolant and oil	kWt	345	374	403
Energy to radiation	kWt	65	81	89
Energy to charge cooler	kWt	133	197	234

4012-46TWG3A - Temperate

Designation	Units	50 Hz @ 1500 rev/min		
		Baseload power	Prime power	Standby power
Energy in fuel	kWt	2278	2889	3245
Energy in power output (gross)	kWb	960	1200	1314
Energy to cooling fan	kWm	51		
Energy in power output (nett)	kWm	909	1149	1263
Energy to exhaust	kWt	745	981	1128
Energy to coolant and oil	kWt	352	395	441
Energy to radiation	kWt	70	87	96
Energy to charge cooler	kWt	151	226	266

4012-46TWG3A - Tropical

Designation	Units	50 Hz @ 1500 rev/min		
		Baseload power	Prime power	Standby power
Energy in fuel	kWt	2294	2910	3269
Energy in power output (gross)	kWb	967	1207	1321
Energy to cooling fan	kWm	58		
Energy in power output (nett)	kWm	909	1149	1263
Energy to exhaust	kWt	751	989	1138
Energy to coolant and oil	kWt	353	398	445
Energy to radiation	kWt	70	88	96
Energy to charge cooler	kWt	153	228	269

Note: Not to be used for combined heat and power (CHP) purposes (indicative figures only), if required, please consult Perkins Engines Company Limited.

Exhaust system

Outlet size (internal) ... 2 x 254 mm
 Outlet flange size ... 10" table D
 Back pressure for total system ... 5 kPa
 For recommended pipe sizes, refer to the Installation Manual.

Induction system

Emissions data with combustion air temperature of 25 °C

Maximum air intake restriction of engine:

-clean filter ... 2 kPa
 -dirty filter ... 4 kPa
 -air filter type ... heavy duty axial flow

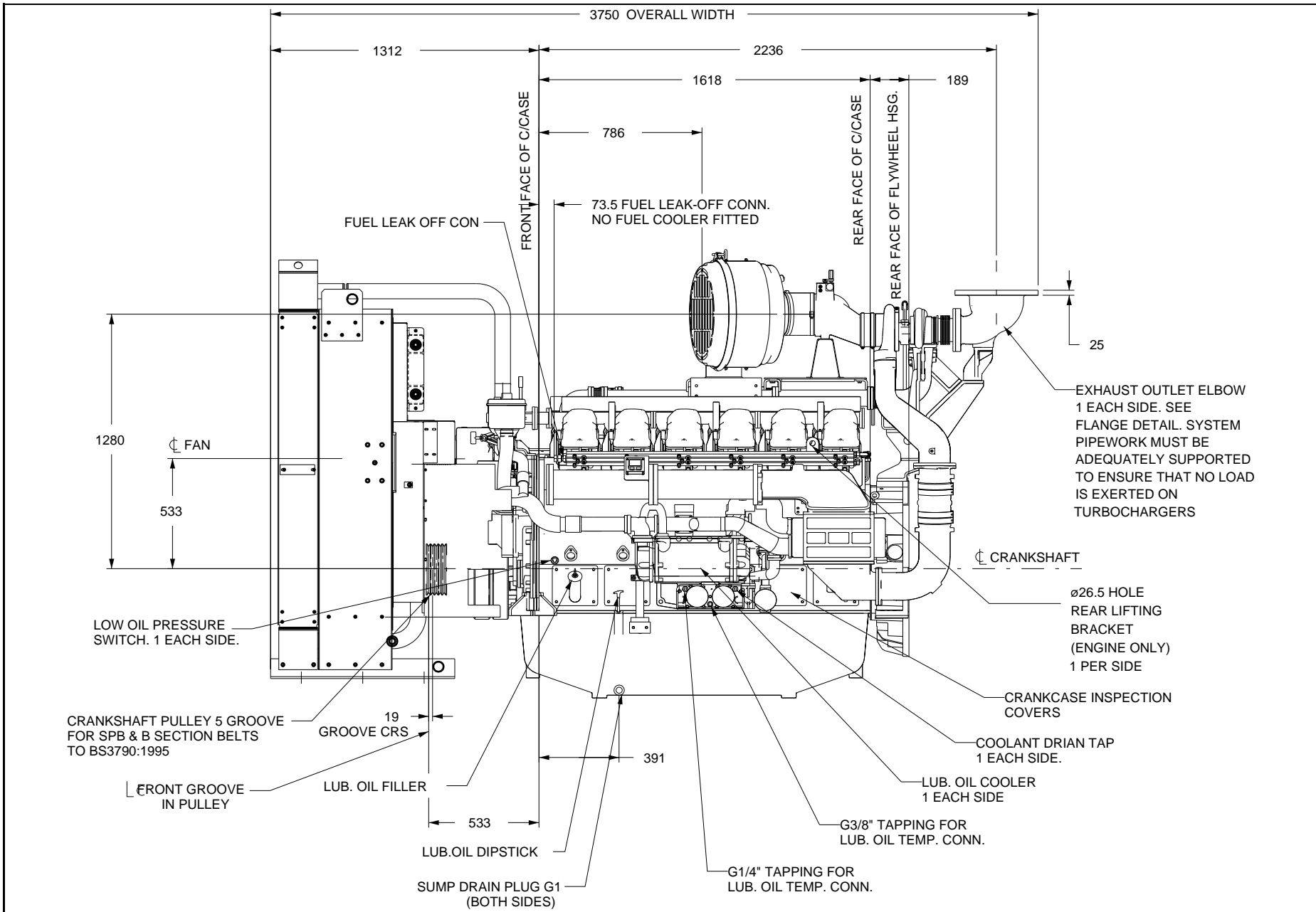

4012-46TWG2A Temperate - front view

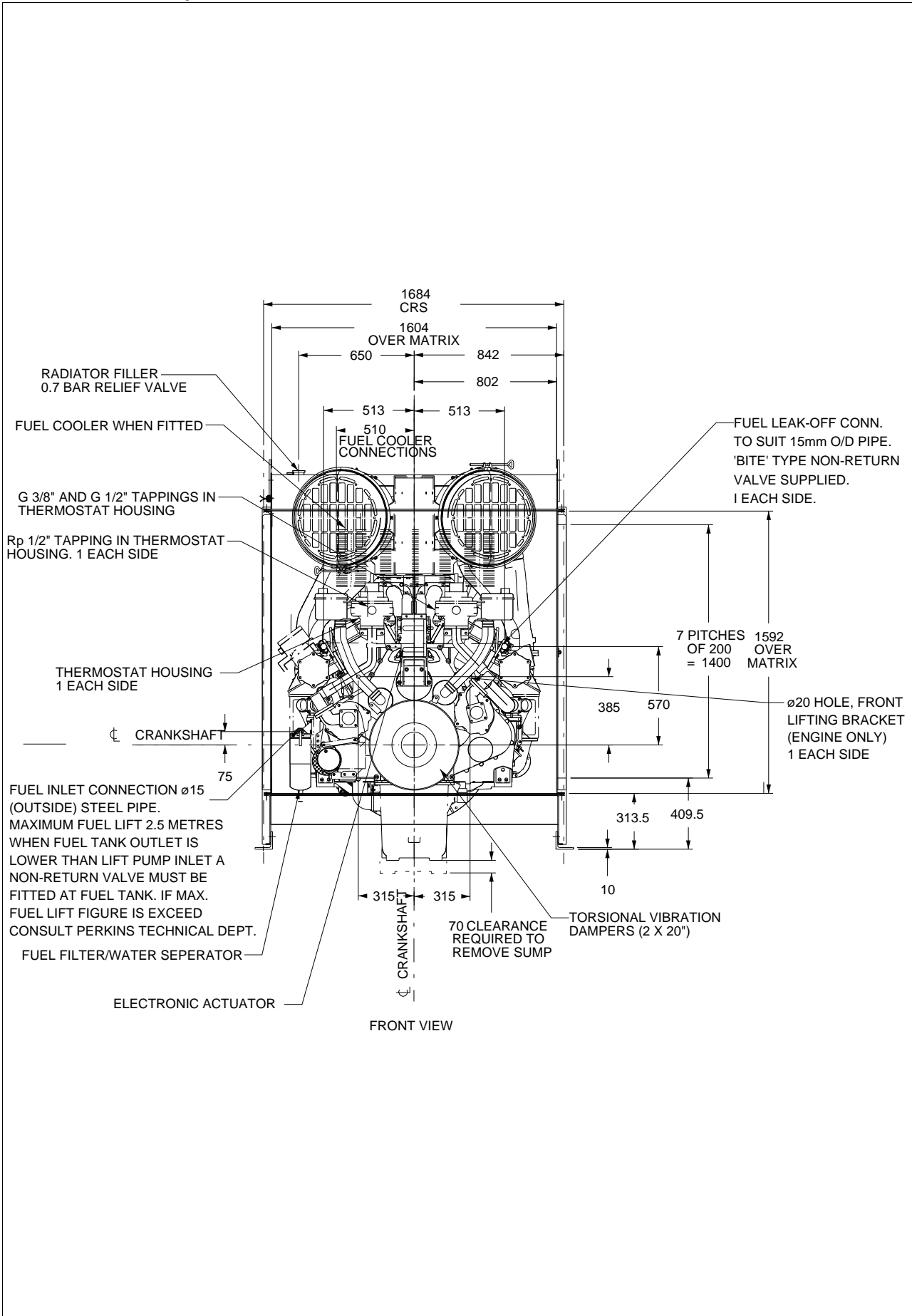

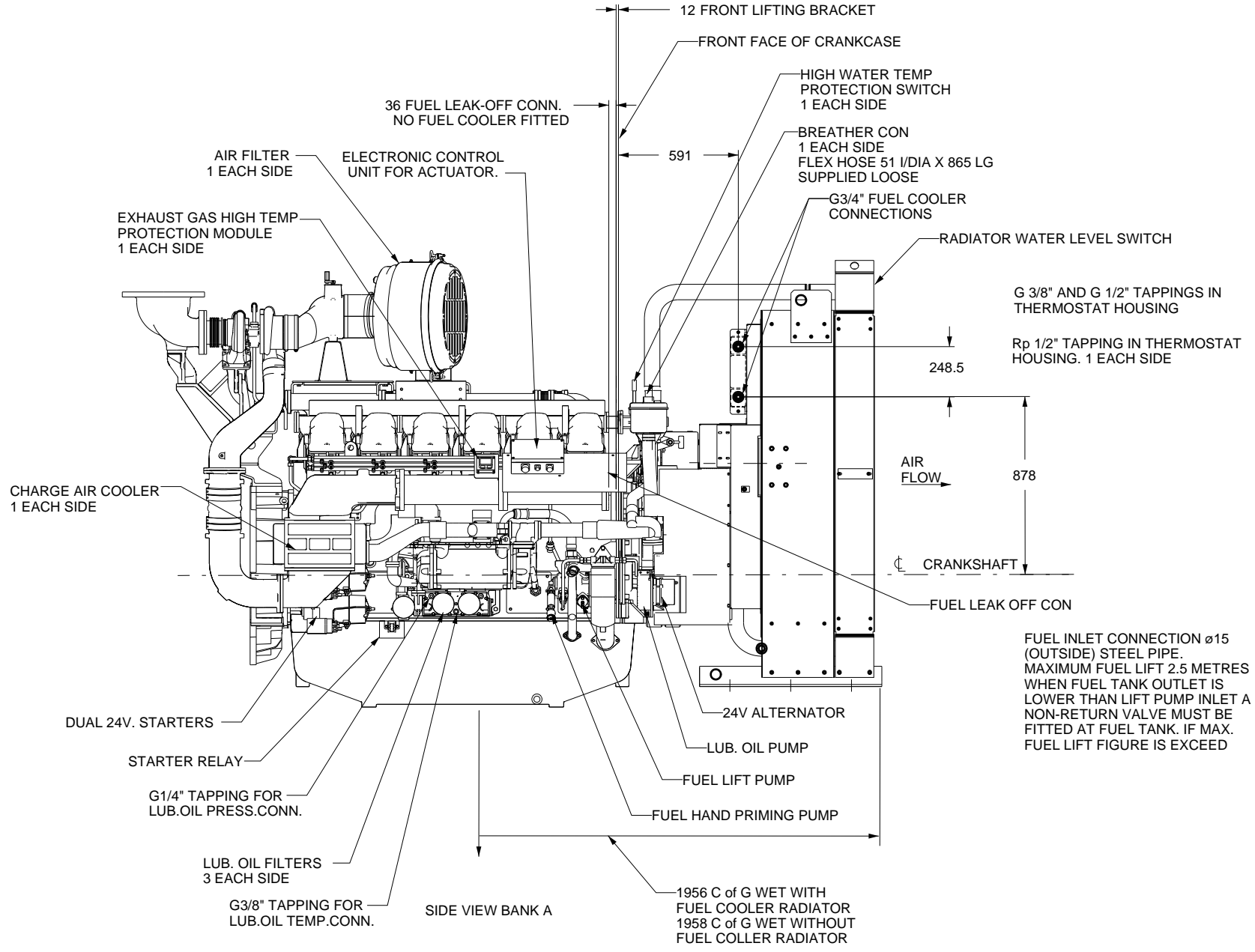

4012-46TWG2A Temperate - rear view

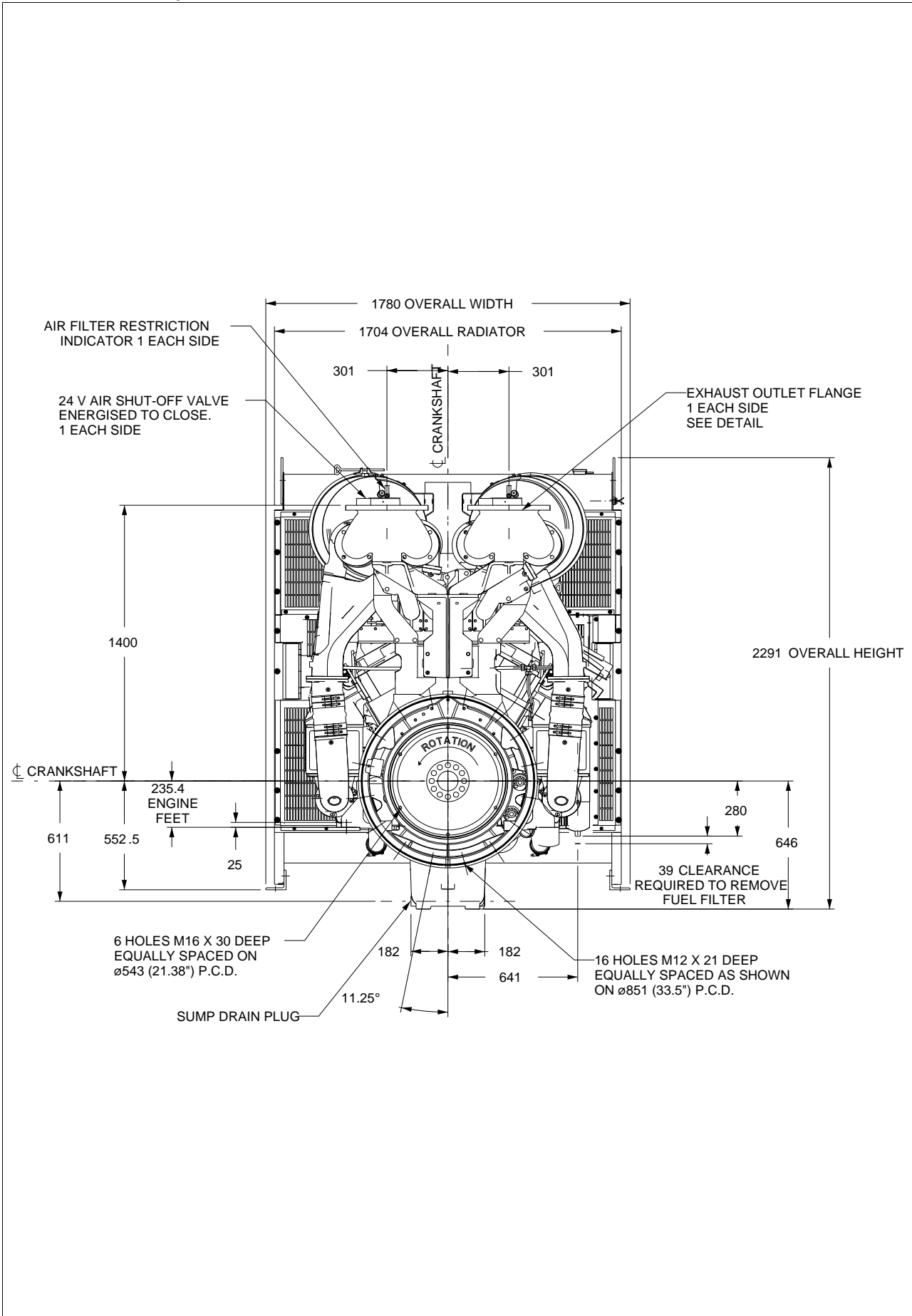

4012-46TWG2A Temperate - Support pads, exhaust outlet flange and flywheel detail

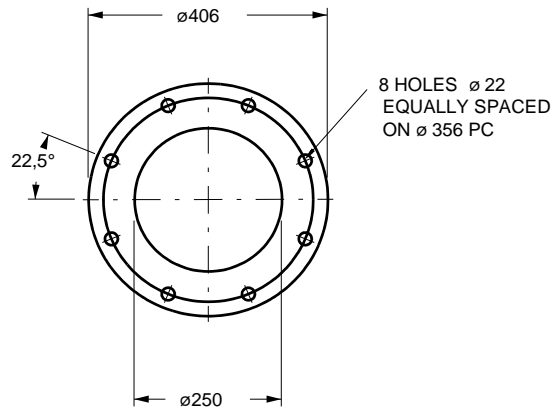

DETAIL OF EXHAUST OUTLET FLANGE
(B.S.10 TABLE D)
SCALE 1:5

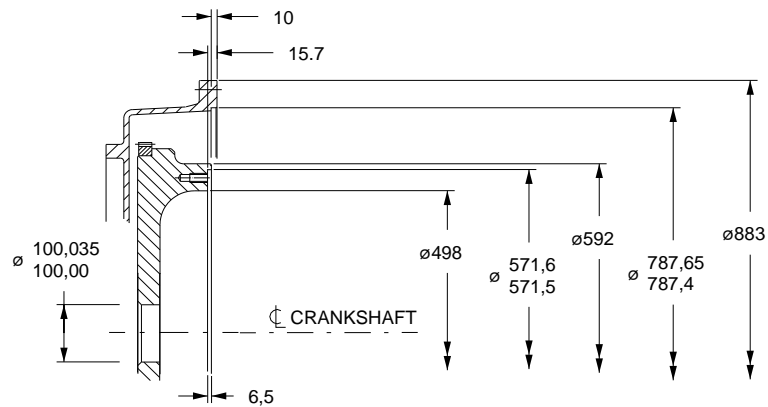

DETAIL OF SAE 518 FLYWHEEL
AND SAE 00 FLYWHEEL HOUSING
(METRIC TAPPINGS)
SCALE 1:5

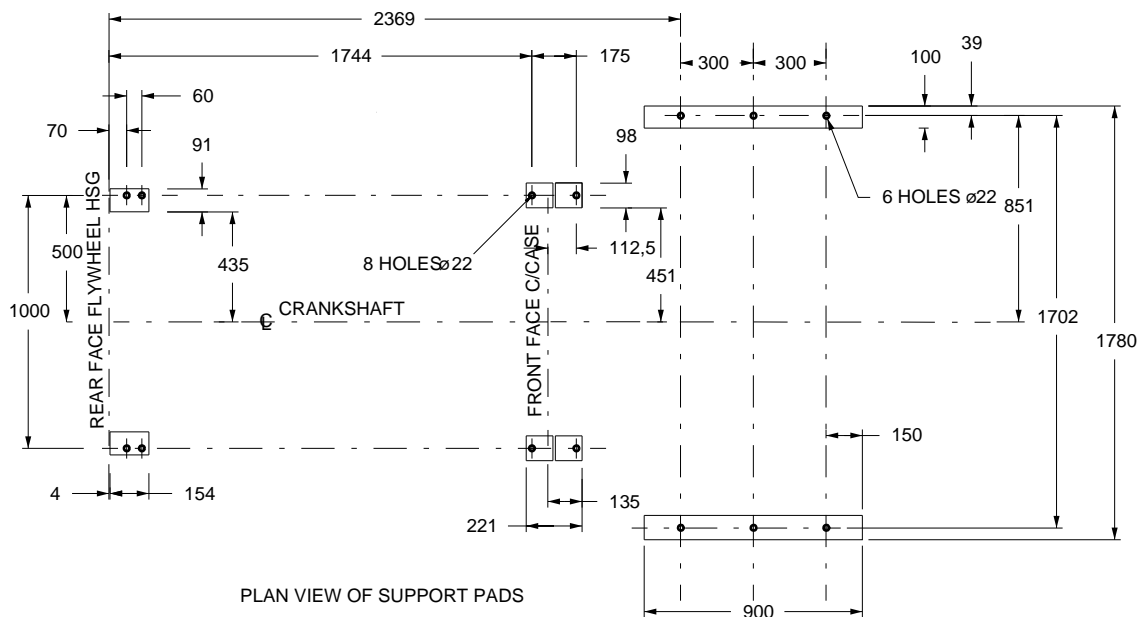

Cooling system

Recommended coolant: 50% inhibited ethylene glycol or 50% inhibited propylene glycol and 50% clean fresh water. For CHP systems and where there is no likelihood of ambient temperature below 10 °C, then clean 'soft' water may be used, treated with 1% by volume of Perkins inhibitor in the cooling system. The inhibitor is available in 1 litre bottles from all Perkins Distributors.

Maximum pressure in crankcase water jacket 170 kPa
 Maximum top tank temperature (standby) 98 °C
 Maximum static pressure on pump 70 kPa
 Maximum pressure cap setting 70 kPa

Total coolant capacity

Electronit (engine only) 73 litres
 ElectropaK
 -temperate (engine and radiator) 196 litres
 -tropical (engine and radiator) 201 litres
 Maximum permissible restriction to coolant pump flow 20 kPa
 Thermostat operating range 71 - 85 °C
 Temperature rise across the engine (standby power) with inhibited coolant 8 °C
 Shutdown switch setting 101 °C (rising)
 Coolant immersion heater capacity 2 x 4 kW

Water jacket cooling data

Coolant flow 948 l/min
 Coolant exit temperature (max) 98 °C
 Coolant inlet temperature (min) 70 °C
 Coolant inlet temperature (max) 85 °C

Coolant pump

-speed 1.4 x engine rev/min
 -method of drive engine (gear) driven

Radiator

Face area
 -temperate 2630400 mm²
 -tropical 2967420 mm²
 Number of rows and material 226
 Fins per inch and material 7
 Width of matrix
 -temperate 1600 mm
 -tropical 1805 mm
 Height of matrix 1644 mm
 Weight (dry)
 -temperate 780 kg
 -tropical 843 kg
 Total coolant capacity
 -temperate 123 litres
 -tropical 128 litres
 Pressure cap setting (min) 69 kPa

Fan

Type engine driven
 Diameter
 -temperate 1400 mm
 -tropical 1530 mm
 Number of blades 12
 Material Aluminium
 Drive ratio
 -temperate 1:1
 -tropical 1:0,9

Cooling clearance

4012-46TWG2A - Temperate

Maximum additional restriction (duct allowance) to cooling airflow, and resultant min airflow			
Description	°C	Pa	m ³ /sec
Ambient clearance: Inhibited coolant	35	N/A	N/A
Duct allowance	35	250	N/A
Minimum airflow	35	250	22

4012-46TWG2A - Tropical

Maximum additional restriction (duct allowance) to cooling airflow, and resultant min airflow			
Description	°C	Pa	m ³ /sec
Ambient clearance: Inhibited coolant	50	N/A	N/A
Duct allowance	50	125	N/A
Minimum airflow	50	125	28

4012-46TWG3A - Temperate

Maximum additional restriction (duct allowance) to cooling airflow, and resultant min airflow			
Description	°C	Pa	m ³ /sec
Ambient clearance: Inhibited coolant	35	N/A	N/A
Duct allowance	35	250	N/A
Minimum airflow	35	250	22

4012-46TWG3A - Tropical

Maximum additional restriction (duct allowance) to cooling airflow, and resultant min airflow			
Description	°C	Pa	m ³ /sec
Ambient clearance: Inhibited coolant	50	N/A	N/A
Duct allowance	50	125	N/A
Minimum airflow	50	125	28

Fuel system

Injection system	direct injection
Fuel injection pump/Injector type	Combined unit injector
Injector pressure	23,4 MPa
Fuel lift pump type.....	Gerotor
Delivery flow.....	1020 litres/hr
Heat retained in fuel to tank	
-4012-46TWG2A	8,5 kW
-4012-46TWG3A	9,0 kW
Fuel inlet temperature to be less than	58 °C
Delivery pressure	300 kPa
Maximum suction head at pump inlet	24,5 kPa
Maximum static pressure head	see installation manual for details
Fuel filter spacing.....	10 microns
Governing type.....	electronic
Governing	to ISO 8528-5 2005
Torque at the governor output shaft.....	1-631
Tolerance on fuel consumption.....	to ISO 8528-1 1993

Fuel specification

Recommended fuel to conform to: -BS2869 1998 class A2 or BS EN590

Fuel consumption

Note: All fuel consumption figures are based on assumed fuel density of 0.862.

4012-46TWG2A - Temperate

Designation	Fuel consumption calculated on nett rated powers	
	1500 rev/min	
	g/kWh	litres/hr
Standby	212	287
Prime power	211	258
Baseload power	213	206
At 75% of Prime power	214	196
At 50% of Prime power	230	141

4012-46TWG3A - Temperate

Designation	Fuel consumption calculated on nett rated powers	
	1500 rev/min	
	g/kWh	litres/hr
Standby	215	315
Prime power	211	281
Baseload power	212	224
At 75% of Prime power	212	212
At 50% of Prime power	224	149

4012-46TWG2A - Tropical

Designation	Fuel consumption calculated on nett rated powers	
	1500 rev/min	
	g/kWh	litres/hr
Standby	213	288
Prime power	212	259
Baseload power	214	207
At 75% of Prime power	216	196
At 50% of Prime power	233	143

4012-46TWG3A - Tropical

Designation	Fuel consumption calculated on nett rated powers	
	1500 rev/min	
	g/kWh	litres/hr
Standby	217	318
Prime power	212	283
Baseload power	213	225
At 75% of Prime power	213	213
At 50% of Prime power	226	151

Electrical system

Alternator
 -type ... insulated return
 -voltage ... 24 volts
 -output ... 40 amps
 Starter
 -type ... (axial) electric
 -motor voltage ... 24 volts
 -motor power ... 16,4 kW
 Number of teeth on
 -flywheel ... 156
 -starter motor ... 12
 Minimum cranking speed ... 120 rev/min
 Starter solenoid (24V)
 -pull in current @ -25 °C max. ... 30 amps
 -hold in current @ -25 °C max ... 9 amps
 Engine stop solenoid current ... 1,1 amps

Engine mounting

Maximum static bending moment at rear face of block ... 1356 Nm
 Maximum additional load applied to flywheel due to rotating components ... 850 kg

Centre of gravity

Bare engine (wet) 4012-46TWG2A / 4012-46TWG3A
 -forward of rear face of cylinder block ... 658 mm
 -above crankshaft centre line ... 32 mm
 ElectropaK (wet) - Temperate
 -forward of rear face of cylinder block ... 960 mm
 -above crankshaft centre line ... 32 mm
 ElectropaK (wet) - Tropical
 -forward of rear face of cylinder block ... 1286 mm
 -above crankshaft centre line ... 32 mm

Cold start recommendations

Temperature range	
Down to 0 °C (32 °F)	Oil: ... API CH4 15W40 Starter: ... 2 x 24 volts Battery: ... 4 x 12V 286 Ah Max breakaway current: ... 1600 amps Cranking current: ... 810 amps Aids: ... block heaters Min mean cranking speed: ... 120 rev/min

Notes:

- The battery capacity is defined by the 20 hour rate
- The oil specification should be for the minimum ambient temperature as the oil will not be warmed by the immersion heater
- Breakaway current is dependant on battery capacity available. Cables should be capable of handling the transient current which may be up to double the steady cranking current.

Lubrication system

Recommended multigrade oil viscosity (15W40) which adequately meets the specifications of API CH4. For further details refer to the engine OMM.

Lubricating oil capacity

Total system ... 177 litres
 Sump maximum ... 157,5 litres
 Sump minimum ... 115 litres
 Oil temperature at normal operating conditions ... 95 °C
 Oil temperature (in rail) - maximum continuous operation .. 105 °C

Lubricating oil pressure

minimum ... 340 kPa
 At rated speed ... 400 kPa
 Oil relief opens ... 400 kPa
 Oil filter screen spacing ... 20 microns
 Sump drain plug tapping size ... G1
 Lubricating oil pump speed ... 1.4 x engine rev/min
 Lubricating oil pump drive method ... engine driven
 Shutdown switch - pressure setting (where fitted) 193 kPa (falling)

Normal operating angles

-front and rear ... 5°
 -side tilt ... 10°

Oil consumption (prime power)		4012-46TWG2A	4012-46TWG3A
After running-in (typically after 250 hours)	g/kWhr	0,52	0,52
Oil flow rate from oil pump	l/s	6,0	6,0

Noise levels

The figures for total noise levels are typical for an engine running at the standby power rating in a semi-reverberant environment and measured at a distance of one metre from the periphery of the engine (sound pressure level re: -20×10^{-6} pa).

Ambient noise level..... 70 dB(A)

Octave analysis

The following diagrams show maximum noise level.

Noise data 4012-46TWG3A, 1500 rev/min 1263 kWb with radiator 584/471FC

Position	SPL dBA
1	114.1
2	112.9
3	113.0
4	111.7
5	113.0
6	114.2

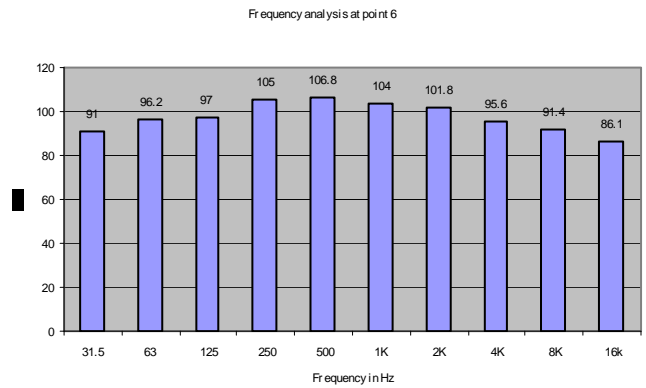
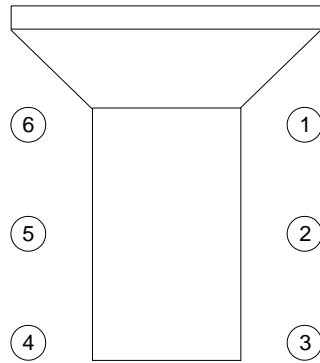

Noise data 4012-46TWG3A, 1500 rev/min 1263 kWb with radiator 584/485FC

Position	SPL dBA
1	113.5
2	113.2
3	112.0
4	111.7
5	113.1
6	112.8

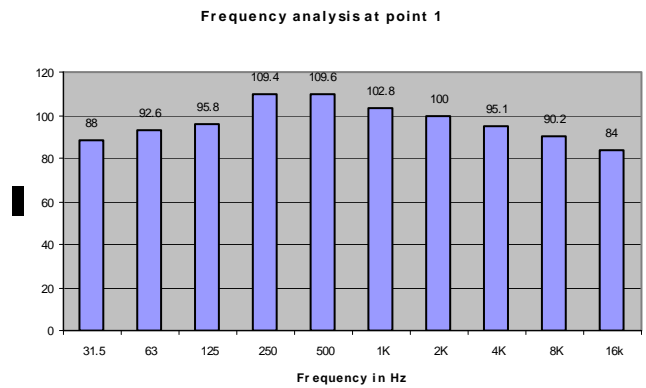
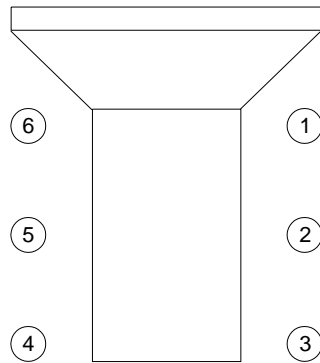

Note: The information given on this Technical Data Sheet is for standard ratings only. For ratings other than those shown, please contact Perkins Engines Company Limited.

Load acceptance (cold)

4012-46TWG2A (prime %)	72
4012-46TWG3A (prime %)	65
Engine block temperature (cold)	45 °C
Ambient temperature	25 °C
Governing mode	Isochronous
Alternator inertia	50 kgm ²
Under frequency roll off (UFRO) point set to	49 Hz
UFRO rate set to	16 V/Hz
LAM on/off	on

Notes:

- All test were conducted using an engine installed and serviced to Perkins Engine Company Limited recommendations.
- Applied load is a percentage of the generator electrical output efficiencies as published in the general installation section of this data sheet.

4000 Series 4012-46TWG2A Diesel Engine – ElectropaK

Non-Emissions compliant

1166 kWm @ 1500 rpm

The 4012-46TWG engine has been developed using the latest engineering techniques and builds on the strengths of the already very successful 4012 Series family and addresses today's uncompromising demands within the power generation industry. Developed from a proven heavy-duty industrial base these products offer superior performance and reliability.

The 4012-46TWG2A is a turbocharged and air-to-water charge-cooled, 12 cylinder diesel engine which offers a choice of temperate or tropical cooling. Its premium features provide exceptional power-to-weight ratio resulting in exceptional fuel consumption.

The overall performance and reliability characteristics makes this one of the prime choices for today's power generation industry.

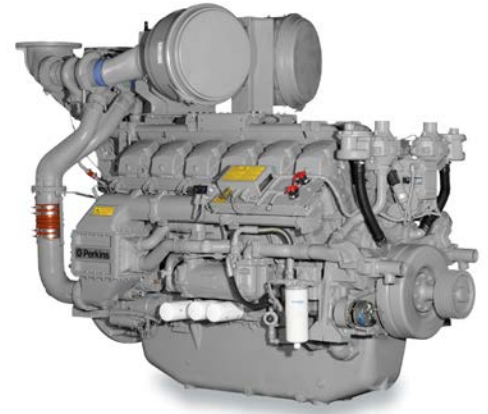

Specification				
Number of cylinders	12 60° Vee form			
Bore and stroke	160 x 190 mm	6.3 x 7.5 in		
Displacement	45.842 litres	2797 in ³		
Aspiration	Turbocharged and air to water charge cooled			
Cycle	4 stroke			
Combustion system	Direct injection			
Compression ratio	13.6:1			
Rotation	Anti-clockwise, viewed from flywheel end			
Total lubricating capacity	177 litres	46.7 US gal		
Cooling system	Water-cooled			
	Temperate		Tropical	
Total coolant capacity	196 litres	51.7 US gal	201 litres	53 US gal

4000 Series 4012-46TWG2A Diesel Engine – ElectropaK

Non-Emissions compliant

1166 kWm @ 1500 rpm

Features and benefits

Economic power

- Individual 4 valve per cylinder give optimised gas flows, while unit fuel injectors ensure ultra fine fuel atomisation and hence controlled rapid combustion for efficiency and economy
- Commonality of components with other engines in the 4000 Series family allows reduced parts stocking levels for the end users

Reliable power

- Developed and tested using latest engineering techniques
- Piston temperatures are controlled by an advanced gallery jet cooling system
- All engines are tolerant of a wide range of temperatures without derate
- Service is provided through the extensive Perkins network of distributors and dealers worldwide

Clean, efficient power

- Exceptional power to weight ratio and compact size for easier transportation and installation
- Designed to provide excellent service access for ease of maintenance
- Engines designed to comply with major international standards
- Low gaseous emissions for cleaner operation

Product support

- Perkins actively pursues product support excellence by ensuring our distribution network invest in their territory – strengthening relationships and providing more value to you, our customer
- Through an experienced global network of distributors and dealers, fully trained engine experts deliver total service support around the clock, 365 days a year. They have a comprehensive suite of web based tools at their fingertips covering technical information, parts identification and ordering systems, all dedicated to maximising the productivity of your engine
- Throughout the entire life of a Perkins engine, we provide access to genuine OE specification parts and service. We give 100% reassurance that you receive the very best in terms of quality for lowest possible cost .. wherever your Perkins powered machine is operating in the world

This engine does not comply with harmonized international regulated emissions limits

4000 Series 4012-46TWG2A Diesel Engine – ElectropaK

Non-Emissions compliant

1166 kWm @ 1500 rpm

Technical information

Air inlet

- Mounted air filters and turbochargers

Fuel system

- Direct fuel injection system with fuel lift pump
- Governing to ISO 8528-5 class G3 with isochronous capability
- Full-flow spin-on fuel oil filters

Lubrication system

- Wet sump with filler and dipstick
- Full-flow spin-on oil filters
- Engine jacket water/lub oil temperature stabiliser

Cooling system

- Two twin thermostats
- System designed for ambients up to 50°C
- Powder coated radiator comprising: water radiator; fuel oil cooling (optional); all pipes, hoses and clips; fan; pulleys; fan belts and safety guards

Electrical equipment

- 24 volt starter motor and 24 volt alternator with integral regulator and DC output
- Overspeed switch and magnetic pickup
- Turbine inlet temperature shutdown switch
- Twin high coolant temperate shutdown switches
- Twin low oil pressure shutdown switches

Flywheel and housing

- Flywheel to SAE J620 size 18
- SAE 00 flywheel housing

Optional equipment

Choice of temperate or tropical radiators available dependant on operational cooling requirements

Fuel oil cooler integral to the radiator assembly

Immersion heater with thermostat

Note: This list is not exhaustive, further options will be available at the product's introduction

4000 Series 4012-46TWG2A Diesel Engine – ElectropaK

Non-Emissions compliant

1166 kWm @ 1500 rpm

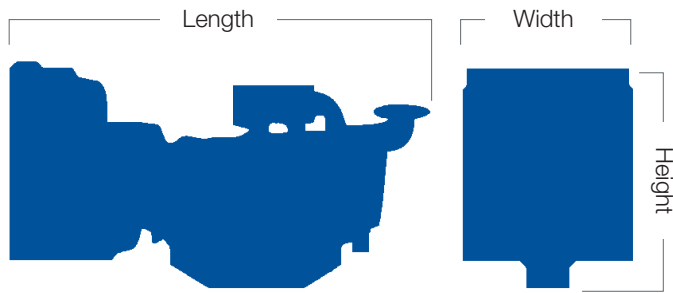

Engine package weights and dimensions				
	Temperate		Tropical	
Length	3714 mm	146 in	3714 mm	146 in
Width	1780 mm	70 in	1978 mm	79 in
Height	2255 mm	89 in	2255 mm	89 in
Weight (dry)	5220 kg	11508 lb	5283 kg	11647 lb

4000 Series 4012-46TWG2A Diesel Engine – ElectropaK

Non-Emissions compliant

1166 kWm @ 1500 rpm

Speed rpm	Type of operation	Typical generator output (Net)		Engine power			
				Gross		Net	
		kVA	kWe	kWm	hp	kWm	hp
1500	Baseload Power	989	791	891	1194	833	1117
	Prime Power	1250	1000	1113	1492	1055	1414
	Standby (maximum)	1385	1108	1224	1641	1166	1563

The above ratings represent the engine performance capabilities guaranteed within plus or minus 3% at the reference conditions equivalent to those specified in ISO 8528/1, ISO 3046/1, BS 5514/1.

Rating conditions: 25°C air inlet temperature, barometric pressure 100 kPa, relative humidity 30%. Please consult your distributor or the factory for ratings in other ambient conditions. *Note: For full ratings please refer to Perkins Engines Company Limited. All electrical ratings are based on an average alternator efficiency and a power factor of 0.8. Fuel specification: BS2869: Class A2.*

Rating definitions

Baseload power: Power available for continuous full load operation. No overload is permitted. **Prime power:** Power available for variable load with an average load factor not exceeding 80% of the prime power rating in any 24 hour period. Overload of 10% permitted for 1 hour in every 12 hours operation. **Standby (maximum):** Power available at variable load in the event of a main power network failure up to a maximum of 500 hours per year. No overload is permitted.

Percent of prime power	Fuel consumption at 1500 rpm g/kWh	Fuel consumption at 1500 rpm l/hr
Standby (maximum)	213	288
Prime power	212	259
Continuous baseload	214	207
75%	216	196
50%	233	143