

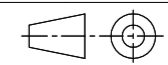

Engine Type	
12M33G10N0/5	12M33G14N0/6

				Title		Dimensional Drawing For Engine 12M33NG	
				Drawing NO.		DPK-MDW-EN-12M33NG-0000-20-05-05	
				Page : 1/4	Unit : mm	Scale : 1/10	Format : A2
05/05/20	First Issue.	/	/	Date : 05/05/20	Designer : T.LIU		
Data	Description	Ref.	Items Modification	Projection Method			
				 <small>Technoparc du Brégadan - 13280 Cassis / France - Tel. +33 488 688 500</small>			



A Detail of Coolant pump inlet flange
1 Each Side
Scale 1:5

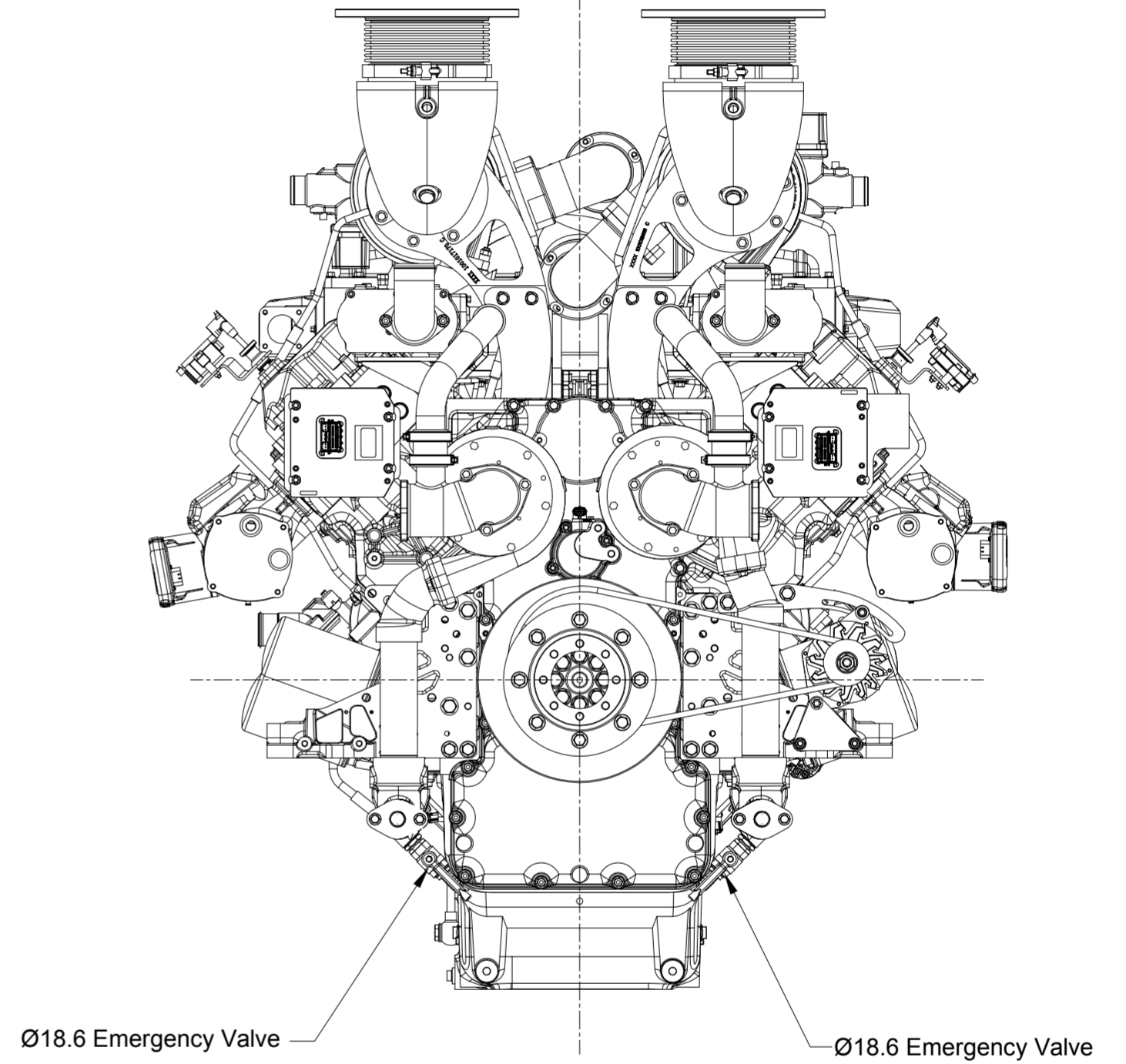
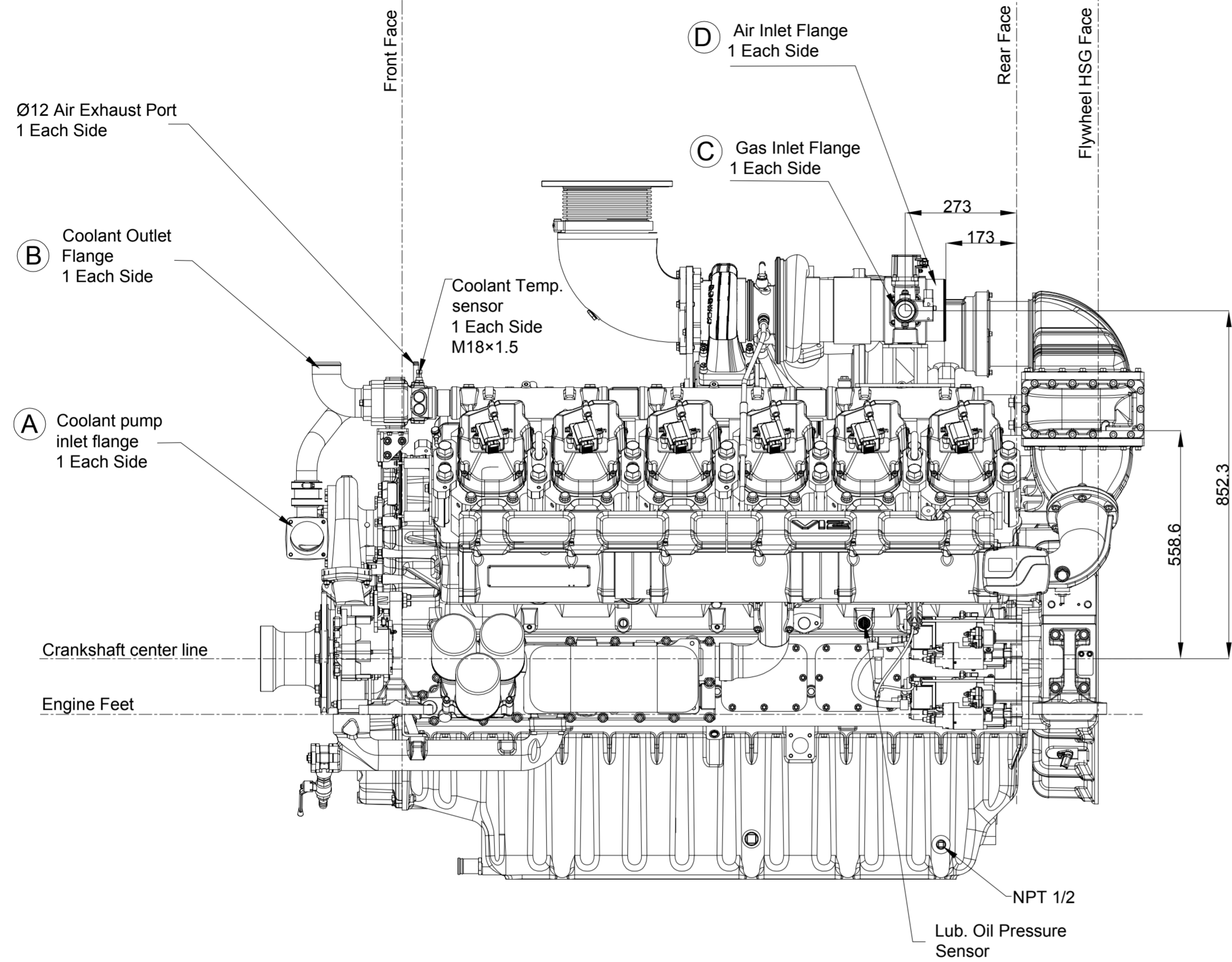
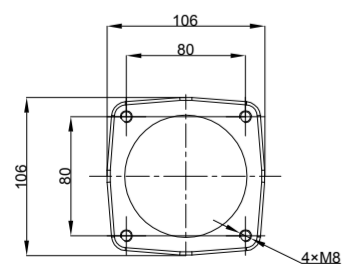

B Detail of Coolant Outlet Flange
1 Each Side
Scale 1:2.5

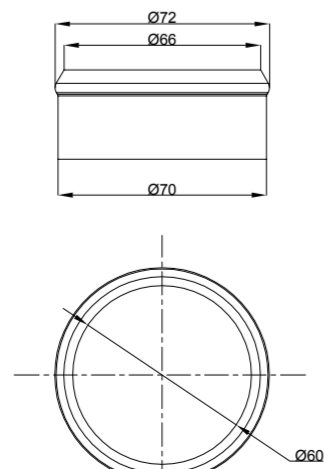

C Detail of Gas Inlet Flange
1 Each Side
Scale 1:2.5

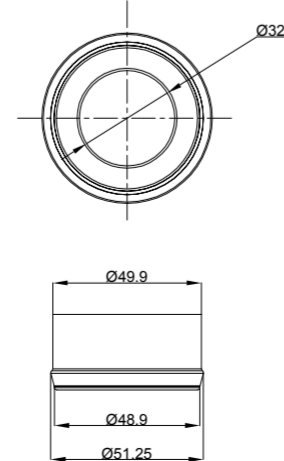

D Detail of Gas Inlet Flange
1 Each Side
Scale 1:5

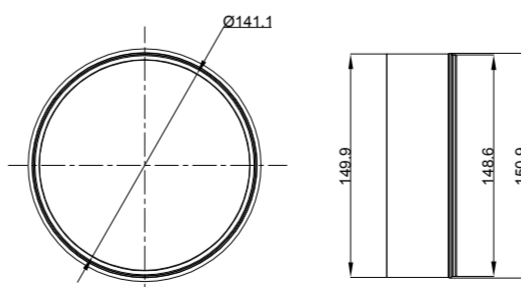

Title		Dimensional Drawing For Engine 12M33NG	
Drawing NO.		DPK-MDW-EN-12M33NG-0000-20-05-05	
Page : 2/4	Unit : mm	Scale : 1/10	Format : A2
Date : 05/05/20	Designer : T.LIU	 <small>Technoparc du Brégadan - 13260 Cassis / France - Tel. +33 488 688 500</small>	
Projection Method			

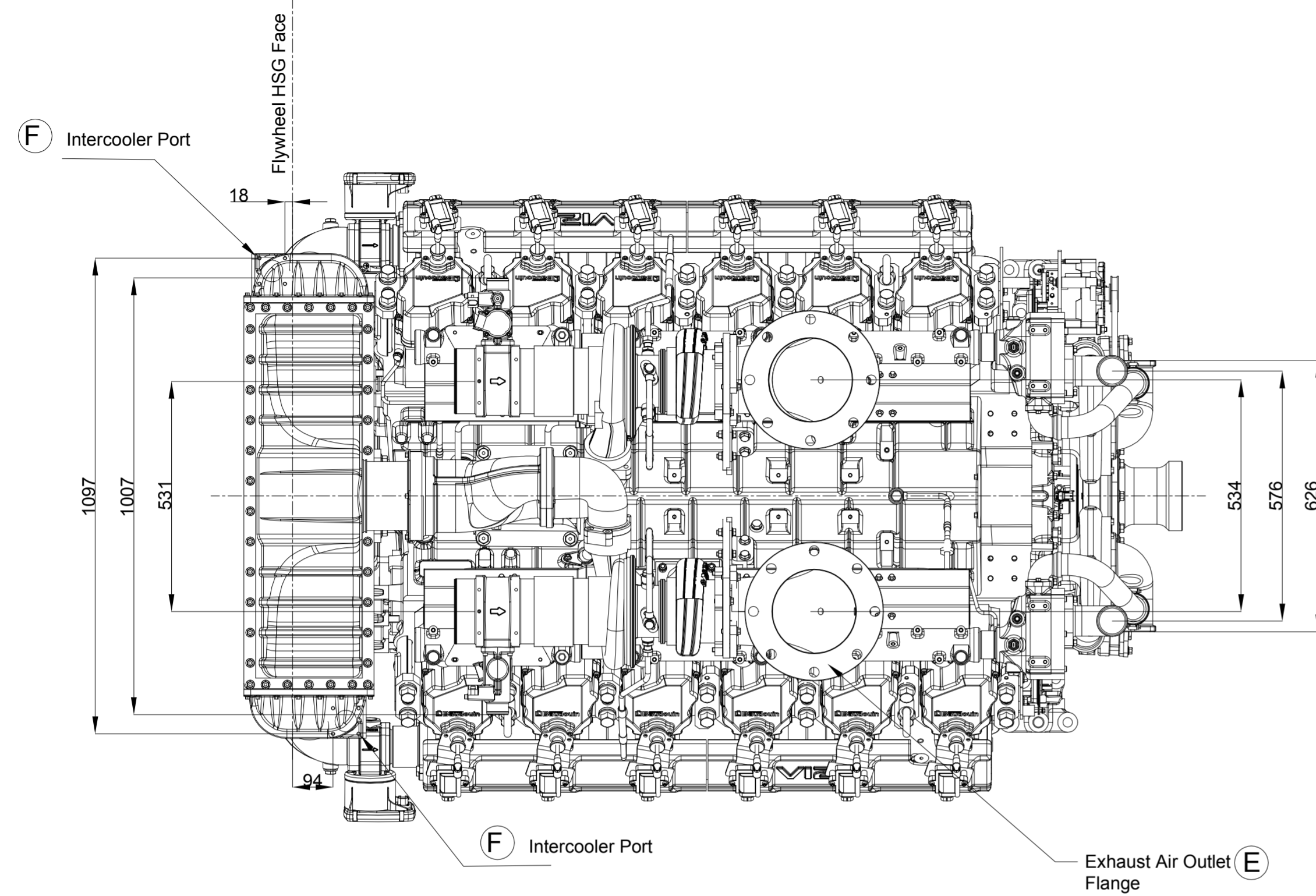

Detail of SAE 0 Flywheel housing and 18° Flywheel
Scale 1:5

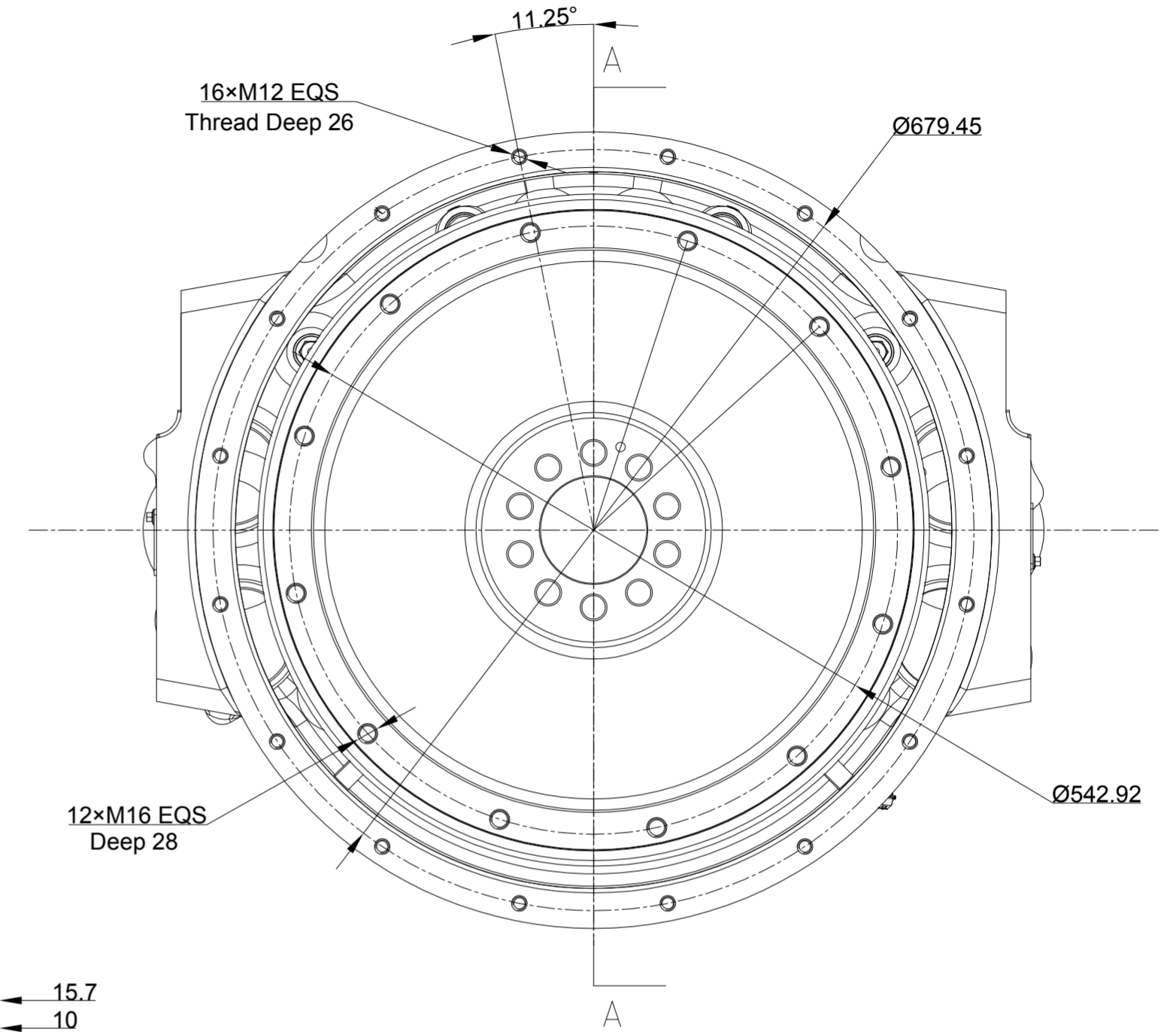

(E) Detail of Exhaust Air Outlet Flange
Scale 1:5

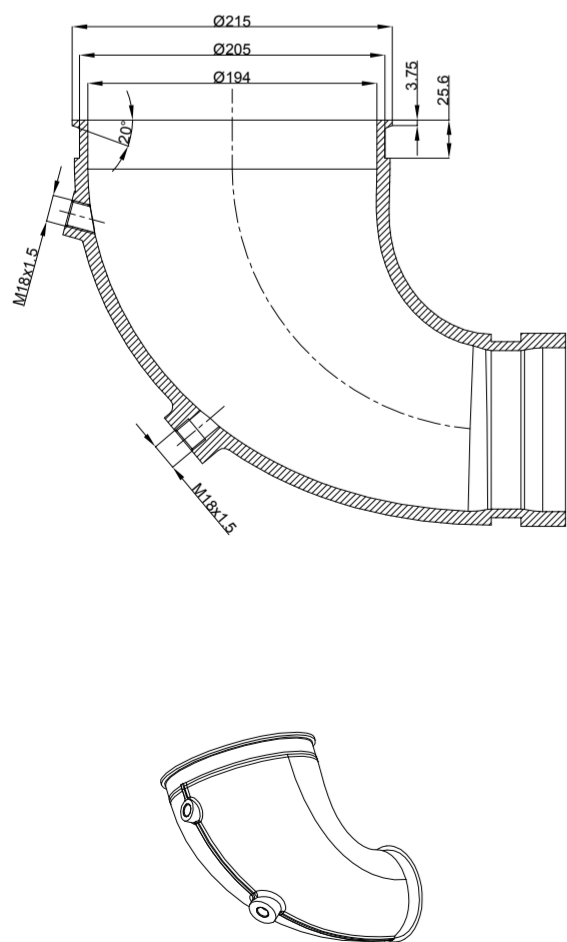

Detail of Exhaust Bellow
Scale 1:5

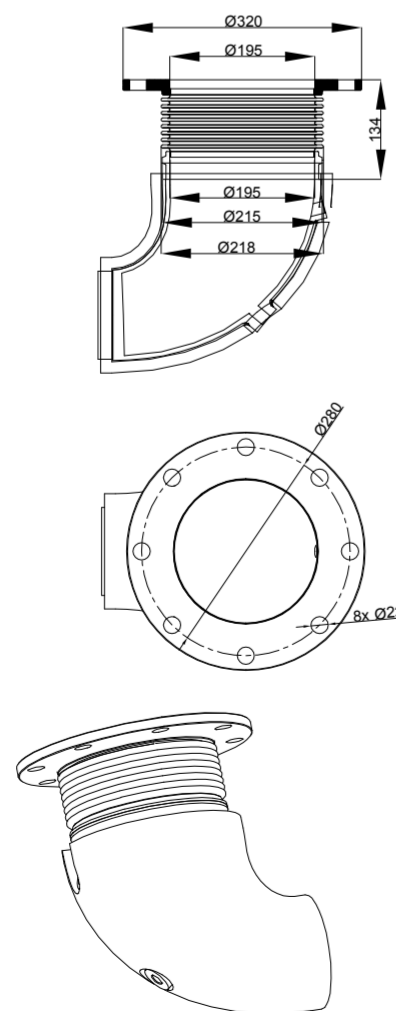

(F) Detail of Intercooler Port
Scale 1:4

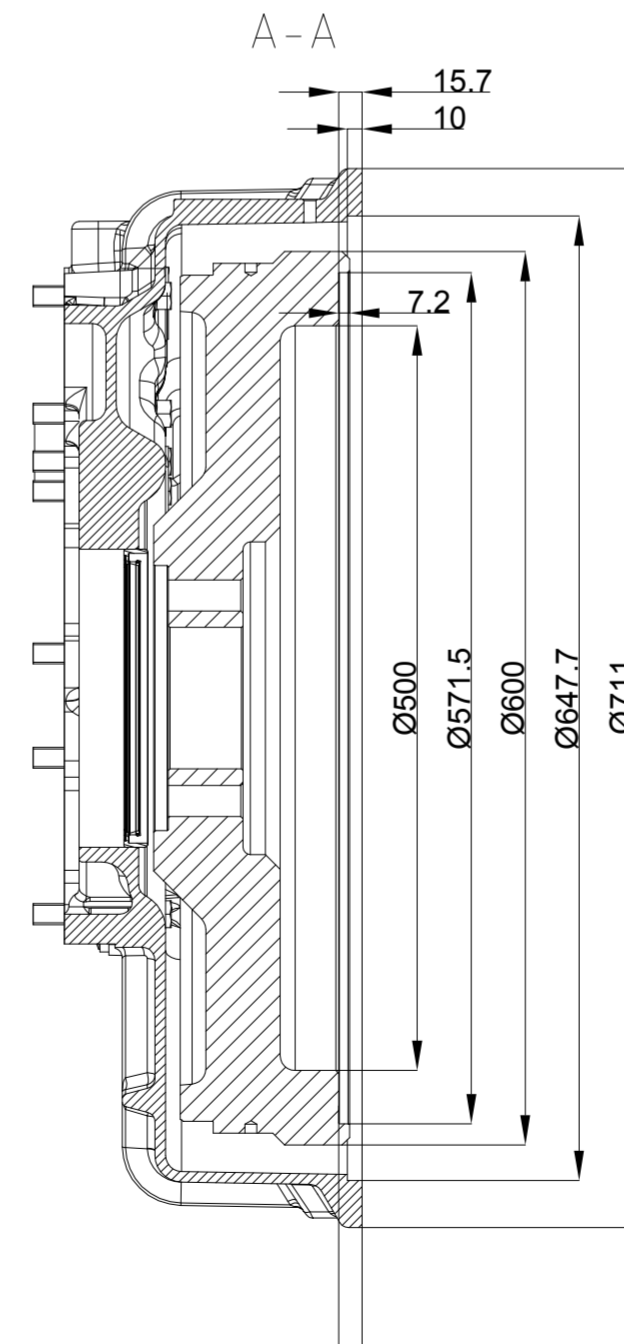
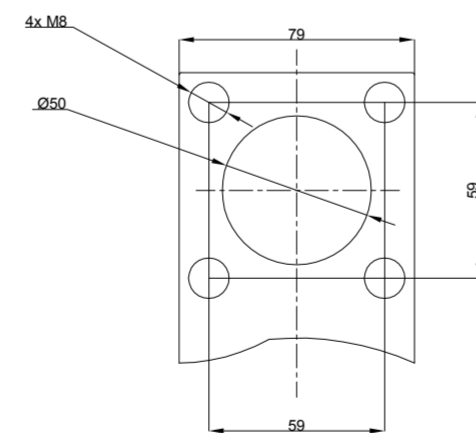

Title		Dimensional Drawing For Engine 12M33NG	
Drawing NO.		DPK-MDW-EN-12M33NG-0000-20-05-05	
Page : 3/4	Unit : mm	Scale : 1/10	Format : A2
Date : 05/05/20	Designer : T.LIU		
Projection Method			
 <small>Technoparc du Brégadan - 13260 Cassis / France - Tel. +33 488 688 500</small>			

